

# ENVISION™

NDW 8 to 15 Tons Hydronic Heat Pump

Installation Information

Water Piping Connections

Electrical Data

Microprocessor Control

Startup Procedures

Preventive Maintenance





## Table of Contents

---

Model Nomenclature . . . . .	4
General Installation Information . . . . .	5
Dimensional Data . . . . .	6
Physical Data . . . . .	7
Field Connected Water Piping . . . . .	8
Typical Application Piping . . . . .	10
Water Quality . . . . .	11
Electrical Data . . . . .	12
Wiring Schematics . . . . .	13
The Aurora Base Control System . . . . .	26
HydroZone Controller Instructions . . . . .	34
Reference Calculations . . . . .	42
Legend . . . . .	42
Unit Startup . . . . .	43
Operating Parameters . . . . .	44
Pressure Drop . . . . .	44
Thermistor and Compressor Resistance . . . . .	45
Heat of Extraction/Rejection Data . . . . .	45
Heating Cycle Analysis . . . . .	46
Cooling Cycle Analysis . . . . .	46
Startup and Troubleshooting Form . . . . .	47
Troubleshooting . . . . .	49
Preventive Maintenance . . . . .	50
Service Parts List . . . . .	51
Revision Guide . . . . .	53

# Model Nomenclature

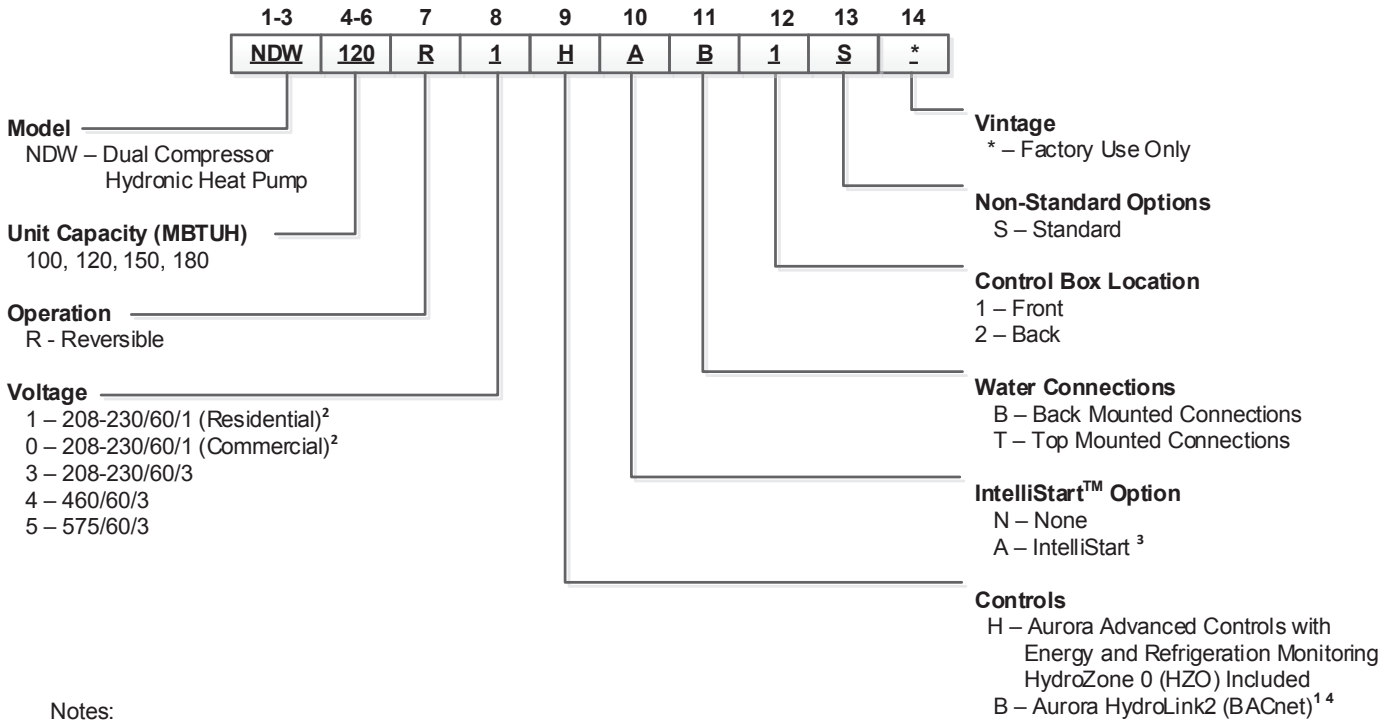

**Notes:**

- 1 – Aurora HydroLink2 controls available for commercial units only.
- 2 – Dual power feed required.
- 3 – IntelliStart Option available for single phase voltage options only.
- 4 – HydroLink2 control option available to Commercial Reps only.

Rev.: 10 Oct 2020B



All Envision Series product is safety listed under UL995 thru ETL and performance listed with AHRI in accordance with standard 13256-2. The Envision Series is also Energy Star rated.

## General Installation Information

### Safety Considerations

Installing and servicing air conditioning and heating equipment can be hazardous due to system pressure and electrical components. Only trained and qualified service personnel should install, repair or service heating and air conditioning equipment. When working on heating and air conditioning equipment, observe precautions in the literature, tags and labels attached to the unit and other safety precautions that may apply.

Follow all safety codes. Wear safety glasses and work gloves. Use quenching cloth for brazing operations. Have fire extinguisher available for all brazing operations.

**NOTE:** Before installing, check voltage of unit(s) to ensure proper voltage.



**WARNING:** Before performing service or maintenance operations on the system, turn off main power switches to the unit. Electrical shock could cause serious personal injury.

### Application

Units are not intended for heating domestic (potable) water by direct coupling. If used for this type of application, a secondary heat exchanger must be used.

### Moving and Storage

Move units in the normal “Up” orientation as indicated by the labels on the unit packaging. When the equipment is received, all items should be carefully checked against the bill of lading to ensure that all crates and cartons have been received in good condition. Examine units for shipping damage, removing unit packaging if necessary to properly inspect unit. Units in question should also be internally inspected. If any damage is observed, the carrier should make the proper notation on delivery receipt acknowledging the damage. Units are to be stored in a location that provides adequate protection from dirt, debris and moisture.



**WARNING:** To avoid equipment damage, do not leave the system filled in a building without heat during cold weather, unless adequate freeze protection levels of antifreeze are used. Heat exchangers do not fully drain and will freeze unless protected, causing permanent damage.

### Unit Location

Provide sufficient room to make water and electrical connections. If the unit is located in a confined space, provisions must be made for unit servicing. Locate the unit in an indoor area that allows easy removal of the access panels and has enough space for service personnel to perform maintenance or repair. These units are not approved for outdoor installation and, therefore, must be installed inside the structure being conditioned. Do not locate units in areas subject to freezing conditions.



**WARNING:** Do not store or install units in corrosive environments or in locations subject to temperature or humidity extremes (e.g. attics, garages, rooftops, etc.). Corrosive conditions and high temperature or humidity can significantly reduce performance, reliability, and service life.



**WARNING:** To avoid equipment damage and possible voiding of warranty, be sure that properly sized strainers are installed upstream of both brazed plate heat exchangers to protect them against particles in the fluid.

### Mounting Units

Prior to setting the unit in place, remove and discard both compressor hold down shipping bolts located at the front of each compressor mounting bracket. Units should be mounted level on a vibration absorbing pad slightly larger than the base to provide isolation between the unit and the floor. It is not necessary to anchor the unit to the floor. Allow access to the front, back, and side access panels for servicing.

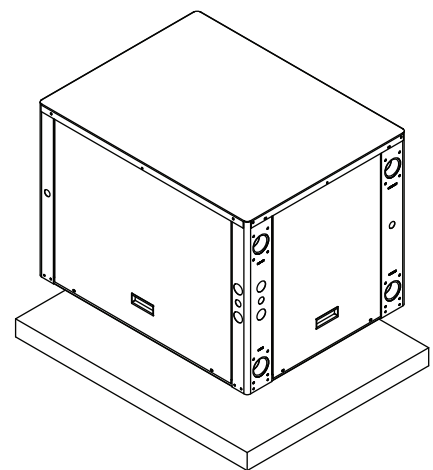

Vibration Pad Mounting

# Dimensional Data

## 100-180 - Top Waterline Configuration

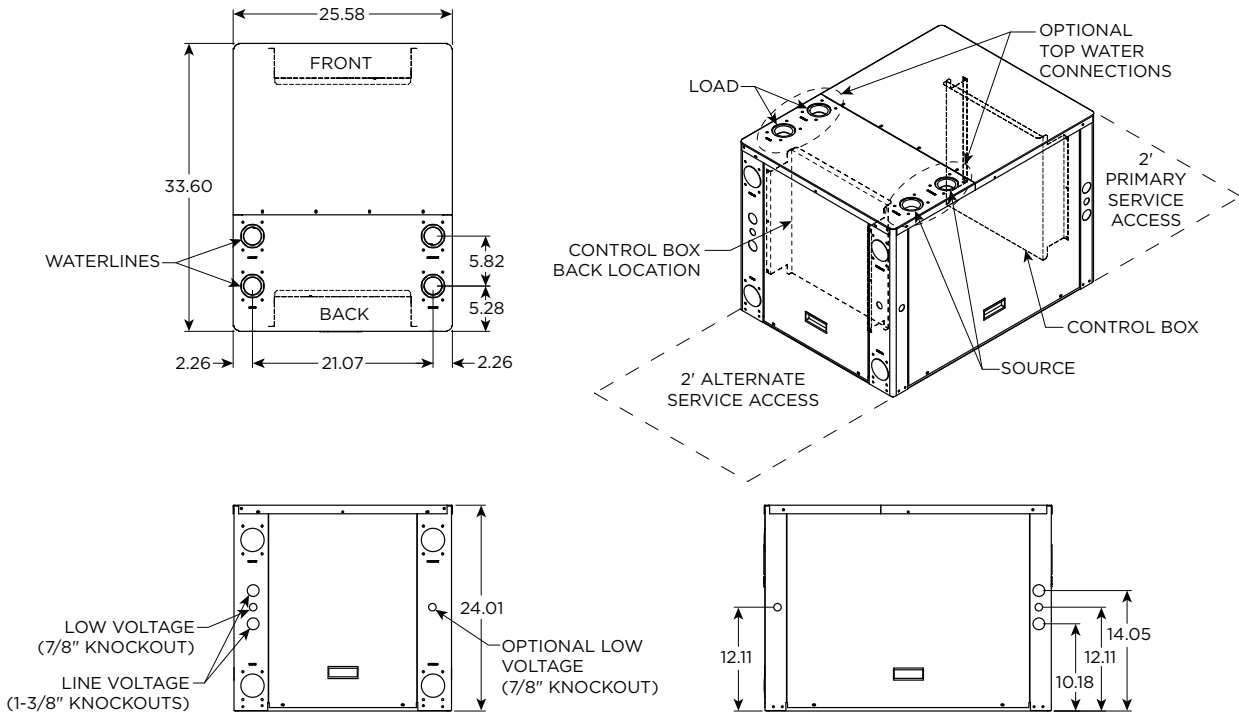

## 100-180 - Back Waterline Configuration

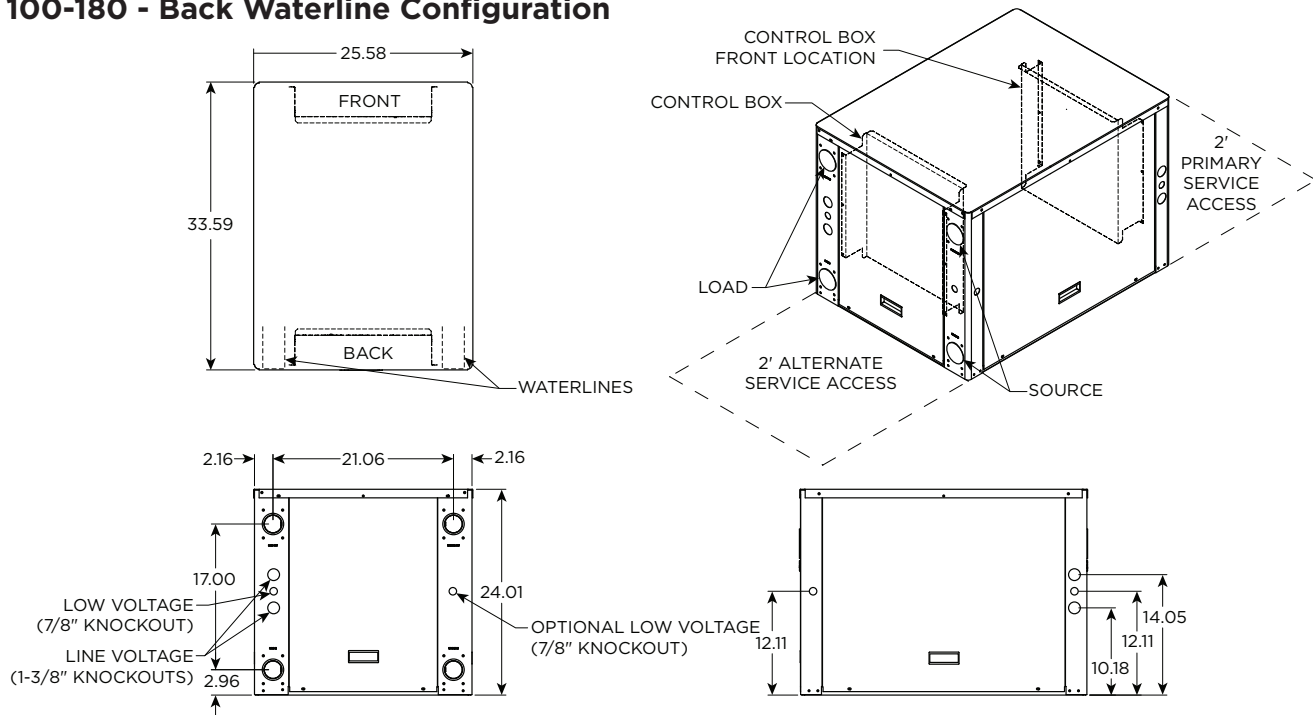

## Physical Data

Model	Model			
	100	120	150	180
Compressor (2 each)	Scroll			
Factory Charge R410A, oz [kg]	46 [1.30]	46 [1.30]	46 [1.30]	54 [1.53]
<b>Load Water Connection</b>				
FPT - in	2	2	2	2
<b>Source Water Connection</b>				
FPT - in	2	2	2	2
Weight - Operating, lb [kg]	390 [177]	400 [181]	400 [181]	420 [190]
Weight - Packaged, lb [kg]	385 [175]	395 [179]	395 [179]	415 [188]

12/29/22

# Field Connected Water Piping

## General

Each unit is equipped with captive 2 in. [50.8 mm] FPT water connections to eliminate 'egg-shaping' from use of a backup wrench. For making the water connections to the unit, a Teflon tape thread sealant is recommended to minimize internal fouling of the piping. Do not over tighten connections.

**NOTE: Units are factory run-tested using propylene glycol. Prior to connecting piping to unit, thoroughly flush heat exchangers.**

The piping installation should provide service personnel with the ability to measure water temperatures and pressures. The water lines should be routed so as not to interfere with access to the unit. The use of a short length of high pressure hose with a swivel type fitting may simplify the connections and prevent vibration. Optional stainless steel hose kits are available as an accessory item.

Before final connection to the unit, the supply and return hose kits must be connected, and the system flushed to remove dirt, piping chips and other foreign material. Normally, a combination balancing and close-off (ball) valve is installed at the return, and a rated gate or ball valve is installed at the supply. The return valve can be adjusted to obtain the proper water flow. The valves allow the unit to be removed for servicing. Both source as well as load fluid piping must be at least as large as the unit connections on the heat pump (larger on long runs).

Never use flexible hoses of a smaller inside diameter than that of the water connection on the unit and limit hose length to 10 ft. per connection. Check carefully for water leaks.

## Load and Source Piping Connections

The Two-Stage Hydronic Series has two connection options available. Each kit is intended to connect one piping connection. Therefore, two kits will be required for each unit. The kits can be mixed for installer convenience, one on source and the other on load.

*CKNDW1* - Strainer Connection Kit includes a 2" copper tee with integral P/T plug and a 2" "Y" strainer. Other components to complete the all copper piping can be sourced locally.

*WFI-XYH200-F-24MO-M* - Strainer Hose Kit set includes 2" Hose kit includes a 2" stainless steel braided hose with integral P/T plug and 2" "Y" strainer.

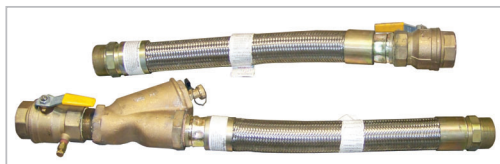

**WFI-XYH200-F-24MO-M**



**CKNDW1**

## Water Flow Rate

The proper water flow must be delivered to each unit whenever the unit heats or cools. To assure proper flow, the use of pressure/temperature ports is recommended to determine the flow rate. These ports should be located adjacent to the supply and return connections on the unit. The proper flow rate cannot be accurately set without measuring the water pressure drop through the refrigerant-to-water heat exchanger (See Pressure Drop Table for water flow and pressure drop information).

## Load Flow Rate

The load flow on all water to water products should be 3 gpm per ton (typically the rated flow and the highest flow shown in the capacity charts). Refer to the table below. This flow rate is required especially when heating water to limit the effects of the higher condensing temperatures of water heating for radiant floor heating or domestic water use.

## Source Flow Rate

The source flow can range between 2.25 and 3 gpm per ton for earth loops. For open loop well water systems the minimum flow should be 1.5 gpm per ton. In earth loop systems where entering water temperatures are expected to be above 95°F, 3 gpm per ton should be used. In well systems where the water temperature is below 50°F, 2 gpm per ton should be used to avoid nuisance freeze detection trips.

	Source Flow Rate				Load Flow Rate
	Minimum Open Loop	Open Loop < 50°F	Closed Loop Range (Min - Full Flow)		
<b>100</b>	15	20	23	30	30
<b>120</b>	18	24	27	36	36
<b>150</b>	21	28	32	42	42
<b>180</b>	24	32	36	48	48

## Flushing

Flushing the system of debris is especially important in brazed plate heat exchanger systems. These systems have many small parallel flow paths in which debris can clog. Initial flushing of the system can be accomplished in one of two ways. First flushing the piping system toward the strainer will allow the strainers to capture all debris prior the heat exchangers and commissioning. Secondly a temporary bypass can be included in the piping design so that the heat pump itself can be bypassed during the initial flushing stage with an external strainer gathering the debris.



**CAUTION: Water piping exposed to outside temperature may be subject to freezing.**



## Field Connected Water Piping cont.

### Closed Loop Tower/Boiler Systems

The water loop is usually maintained between 60°F [15.5°C] and 90°F [32.2°C] for proper heating and cooling operation. This is accomplished with a cooling tower and a boiler.

To reject excess heat from the condenser water loop, the use of a closed-circuit evaporative cooler or an open type cooling tower with a secondary heat exchanger between the tower and the condenser water loop is recommended. If an open type cooling tower is used without a secondary heat exchanger, continuous chemical treatment and filtering of the water must be performed to ensure the water is free from damaging materials.



**CAUTION: Water piping exposed to outside temperature may be subject to freezing.**

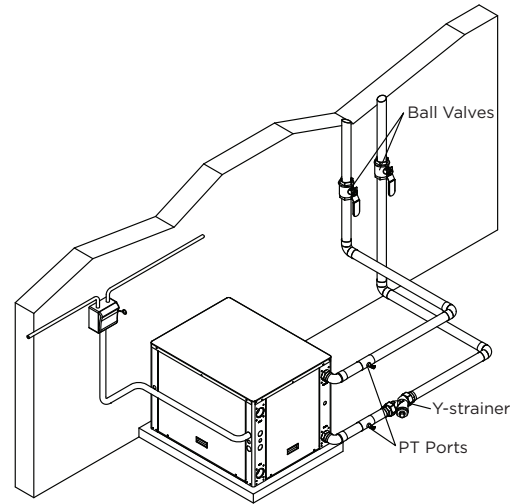

**Closed Loop (Boiler/Tower) Systems**

### Open Loop Well Water Systems

Installation of an open loop system is not recommended unless water quality guidelines are met.

### Earth Coupled Systems

All supply and return water piping should be insulated to prevent excess condensation from forming on the water lines. Ensure pumping system is capable of providing adequate flow rate at the system pressure drop, 3.0 GPM per ton [0.054 LPS per kW] (source side) is recommended. Antifreeze in the loop is strongly recommended.

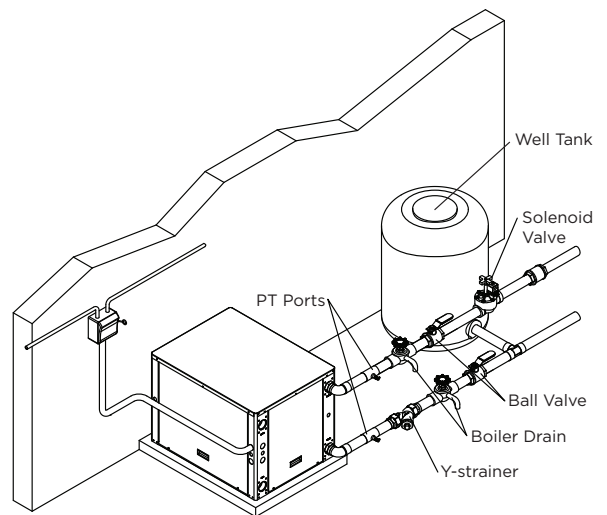

**Open Loop Well Water Systems**

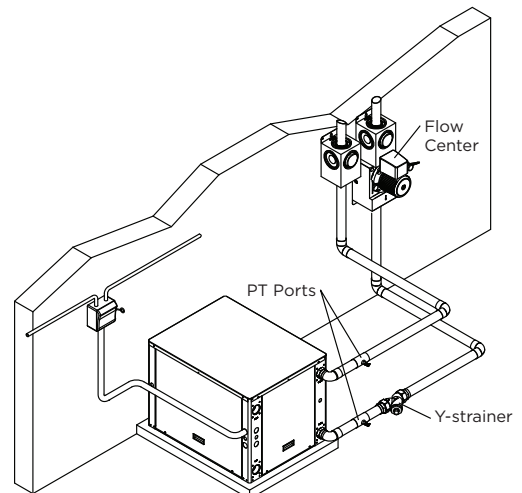

**Earth Coupled Systems**

# Typical Application Piping

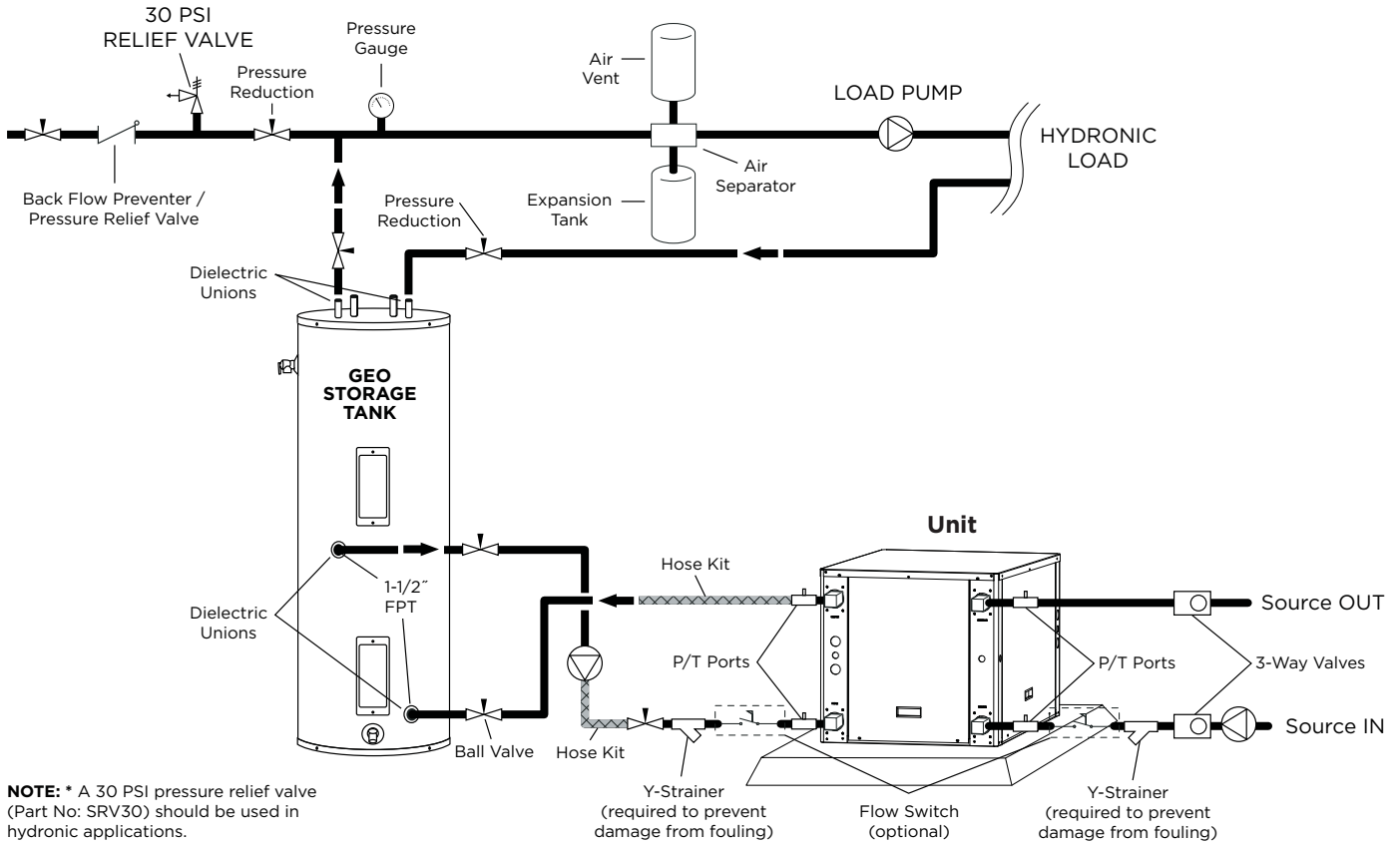

# Water Quality

## General

Two-Stage Hydronic systems may be successfully applied in a wide range of residential, commercial, and industrial applications. It is the responsibility of the system designer and installing contractor to ensure that acceptable water quality is present and that all applicable codes have been met in these installations.

## Water Treatment

Do not use untreated or improperly treated water. Equipment damage may occur. The use of improperly treated or untreated water in this equipment may result in scaling, erosion, corrosion, algae or slime. The services of a qualified water treatment specialist should be engaged to determine what treatment, if any, is required. The product warranty specifically excludes liability for corrosion, erosion or deterioration of equipment.

The heat exchangers in the units are 316 stainless steel plates with copper brazing. The water piping in the heat exchanger is steel. There may be other materials in the building's piping system that the designer may need to take into consideration when deciding the parameters of the water quality.

If an antifreeze or water treatment solution is to be used, the designer should confirm it does not have a detrimental effect on the materials in the system.

## Contaminated Water

In applications where the water quality cannot be held to prescribed limits, the use of a secondary or intermediate heat exchanger is recommended to separate the unit from the contaminated water.

The following table outlines the water quality guidelines for unit heat exchangers. If these conditions are exceeded, a secondary heat exchanger is required. Failure to supply a secondary heat exchanger where needed will result in a warranty exclusion for primary heat exchanger corrosion or failure.

## Strainers

These units must have properly sized strainers upstream of both brazed plate heat exchangers to protect them against particles in the fluid. Failure to install proper strainers and perform regular service can result in serious damage to the unit, and cause degraded performance, reduced operating life and failed compressors. Improper installation of the unit (which includes not having proper strainers to protect the heat exchangers) can also result in voiding the warranty.

Field supplied strainers with 20-40 mesh (530-1060 microns) are recommended, with 30 mesh (800 microns) being the optimum choice. The strainers selected should have a mesh open area of at least 6 square inches (39 square centimeters) for each unit being serviced by the strainer. Using strainers with a smaller amount of open area will result in the need for more frequent cleaning.

Strainers should be selected on the basis of acceptable pressure drop, and not on pipe diameter. The strainers selected should have a pressure drop at the nominal flow rate of the units low enough to be within the pumping capacity of the pump being used.



**WARNING: Must have intermediate heat exchanger when used in pool applications.**

## Water Quality Guidelines

Material		Copper	90/10 Cupronickel	316 Stainless Steel
pH	Acidity/Alkalinity	7 - 9	7 - 9	7 - 9
Scaling	Calcium and Magnesium Carbonate	(Total Hardness) less than 350 ppm	(Total Hardness) less than 350 ppm	(Total Hardness) less than 350 ppm
Corrosion	Hydrogen Sulfide	Less than 0.5 ppm (rotten egg smell appears at 0.5 ppm)	10 - 50 ppm	Less than 1 ppm
	Sulfates	Less than 125 ppm	Less than 125 ppm	Less than 200 ppm
	Chlorine	Less than 0.5 ppm	Less than 0.5 ppm	Less than 0.5 ppm
	Chlorides	Less than 20 ppm	Less than 125 ppm	Less than 300 ppm
	Carbon Dioxide	Less than 50 ppm	10 - 50 ppm	10 - 50 ppm
	Ammonia	Less than 2 ppm	Less than 2 ppm	Less than 20 ppm
	Ammonia Chloride	Less than 0.5 ppm	Less than 0.5 ppm	Less than 0.5 ppm
	Ammonia Nitrate	Less than 0.5 ppm	Less than 0.5 ppm	Less than 0.5 ppm
	Ammonia Hydroxide	Less than 0.5 ppm	Less than 0.5 ppm	Less than 0.5 ppm
	Ammonia Sulfate	Less than 0.5 ppm	Less than 0.5 ppm	Less than 0.5 ppm
	Total Dissolved Solids (TDS)	Less than 1000 ppm	1000 - 1500 ppm	1000 - 1500 ppm
	LSI Index	+0.5 to -0.5	+0.5 to -0.5	+0.5 to -0.5
Iron Fouling (Biological Growth)	Iron, FE <sup>2+</sup> (Ferrous) Bacterial Iron Potential	< 0.2 ppm	< 0.2 ppm	< 0.2 ppm
	Iron Oxide	Less than 1 ppm, above this level deposition will occur	Less than 1 ppm, above this level deposition will occur	Less than 1 ppm, above this level deposition will occur
Erosion	Suspended Solids	Less than 10 ppm and filtered for max. of 600 micron size	Less than 10 ppm and filtered for max. of 600 micron size	Less than 10 ppm and filtered for max. of 600 micron size
	Threshold Velocity (Fresh Water)	< 6 ft/sec	< 6 ft/sec	< 6 ft/sec

NOTES: Grains = ppm divided by 17  
mg/L is equivalent to ppm

2/22/12

# Electrical Data

Model	Supply Circuit	Rated Voltage	Voltage Min/Max	Compressor*				Load Pump FLA	Source Pump FLA	Total Unit FLA	Min Circ Amp	Max Fuse/HACR
				MCC	RLA	LRA	LRA**					
100	L1/L2	208-230/60/1	187/253	41.2	26.4	134.0	47.0	-	-	26.4	33.0	50
	L3/L4	208-230/60/1	187/253	41.2	26.4	134.0	47.0	4.2	4.2	34.8	41.4	60
	Single	208-230/60/3	187/253	24.9	16.0	110.0	66.0	-	-	32.0	36.0	50
	Single	460/60/3	414/506	12.1	7.8	52.0	31.0	-	-	15.6	17.6	25
	Single	575/60/3	517/633	8.9	5.7	38.9	-	-	-	11.4	12.8	15
120	L1/L2	208-230/60/1	187/253	47.0	30.1	145.0	51.0	-	-	30.1	37.6	60
	L3/L4	208-230/60/1	187/253	47.0	30.1	145.0	51.0	4.2	4.2	38.5	46.0	70
	Single	208-230/60/3	187/253	28.0	17.3	120.0	72.0	-	-	34.6	38.9	50
	Single	460/60/3	414/506	15.0	9.6	70.0	42.0	-	-	19.2	21.6	30
	Single	575/60/3	517/633	12.5	8.0	53.0	-	-	-	16.0	18.0	25
150	L1/L2	208-230/60/1	187/253	42.0	26.9	145.0	51.0	-	-	26.9	33.6	60
	L3/L4	208-230/60/1	187/253	42.0	26.9	145.0	51.0	4.2	4.2	35.3	42.0	60
	Single	208-230/60/3	187/253	35.0	22.4	190.0	114.0	-	-	44.8	50.4	70
	Single	460/60/3	414/506	19.0	12.2	87.0	52.0	-	-	24.4	27.5	30
	Single	575/60/3	517/633	15.0	9.6	62.0	-	-	-	19.2	21.6	30
180	L1/L2	208-230/60/1	187/253	50.0	32.1	185.0	65.0	-	-	32.1	40.1	70
	L3/L4	208-230/60/1	187/253	50.0	32.1	185.0	65.0	4.2	4.2	40.5	48.5	80
	Single	208-230/60/3	187/253	39.0	26.0	190.0	114.0	-	-	52.0	58.5	80
	Single	460/60/3	414/506	19.0	13.0	100.0	60.0	-	-	26.0	29.3	40
	Single	575/60/3	517/633	14.5	9.3	72.0	-	-	-	18.6	20.9	30

3/7/13

HACR circuit breaker in USA only

\* Ratings per each compressor - unit supplied with two

\*\* With optional IntelliStart

Figure 1 - Control Box

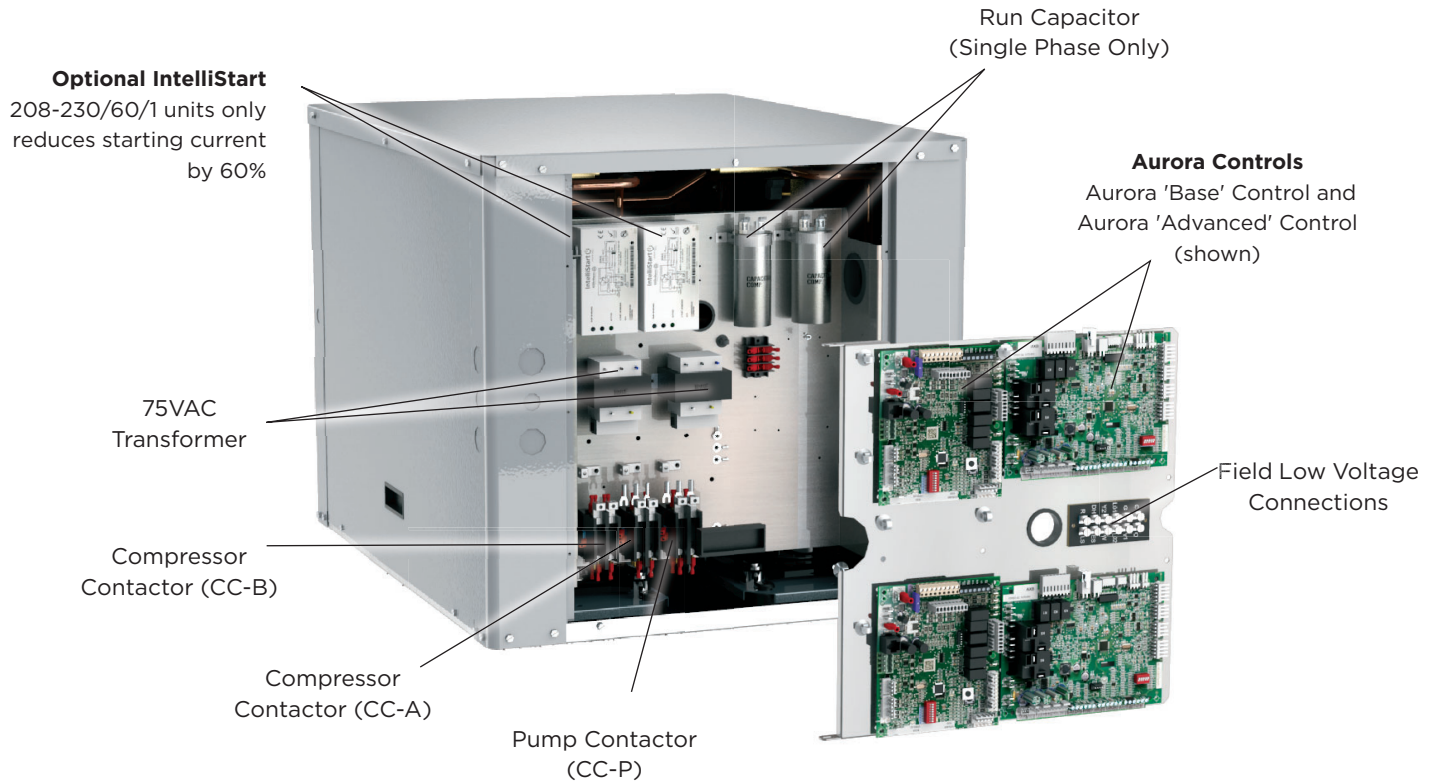

## **Wiring Schematics**

# Wiring Schematics

## 208-230/60/1 Supply Power with HydroZone

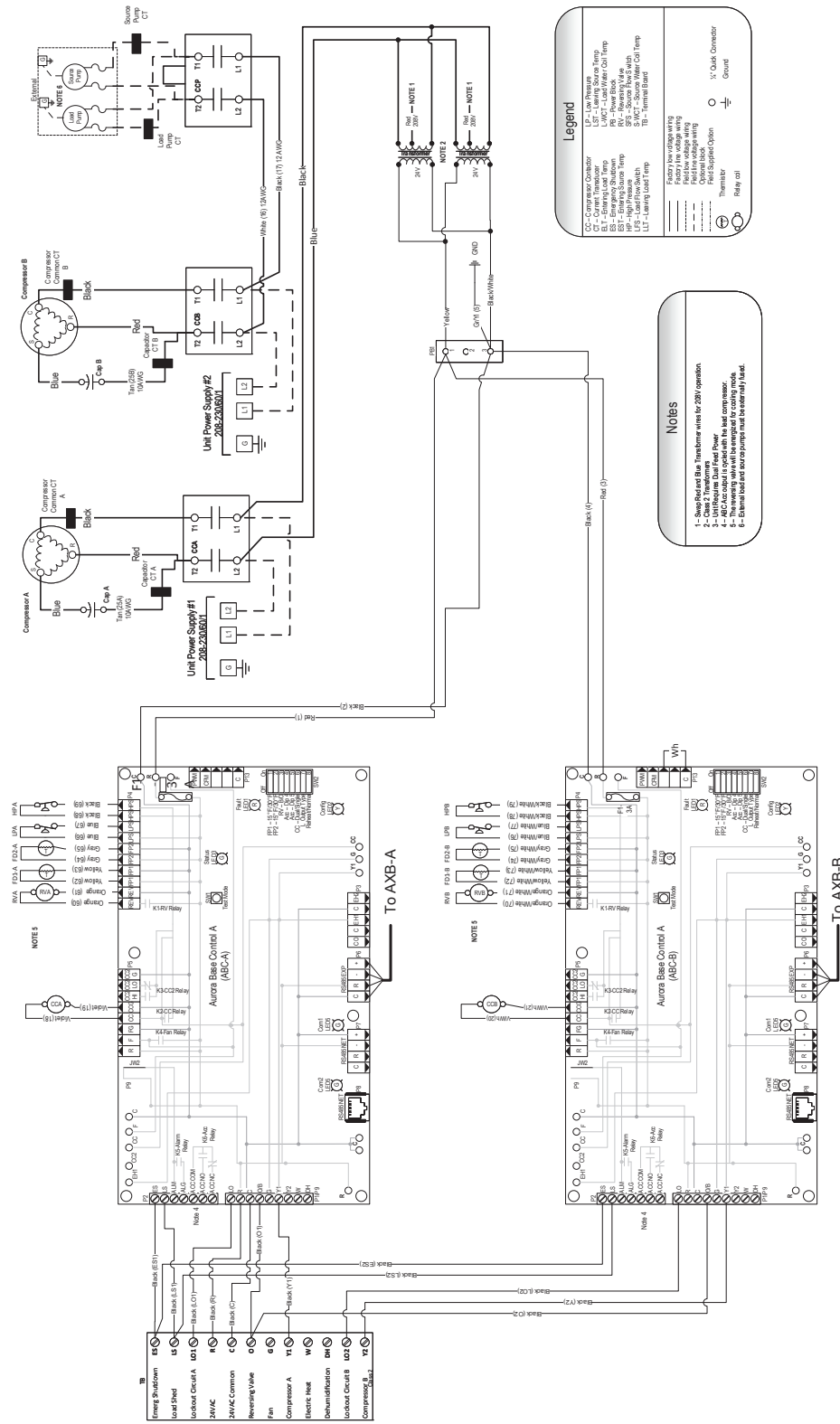

# Wiring Schematics cont.

## 208-230/60/1 Supply Power HydroZone continued

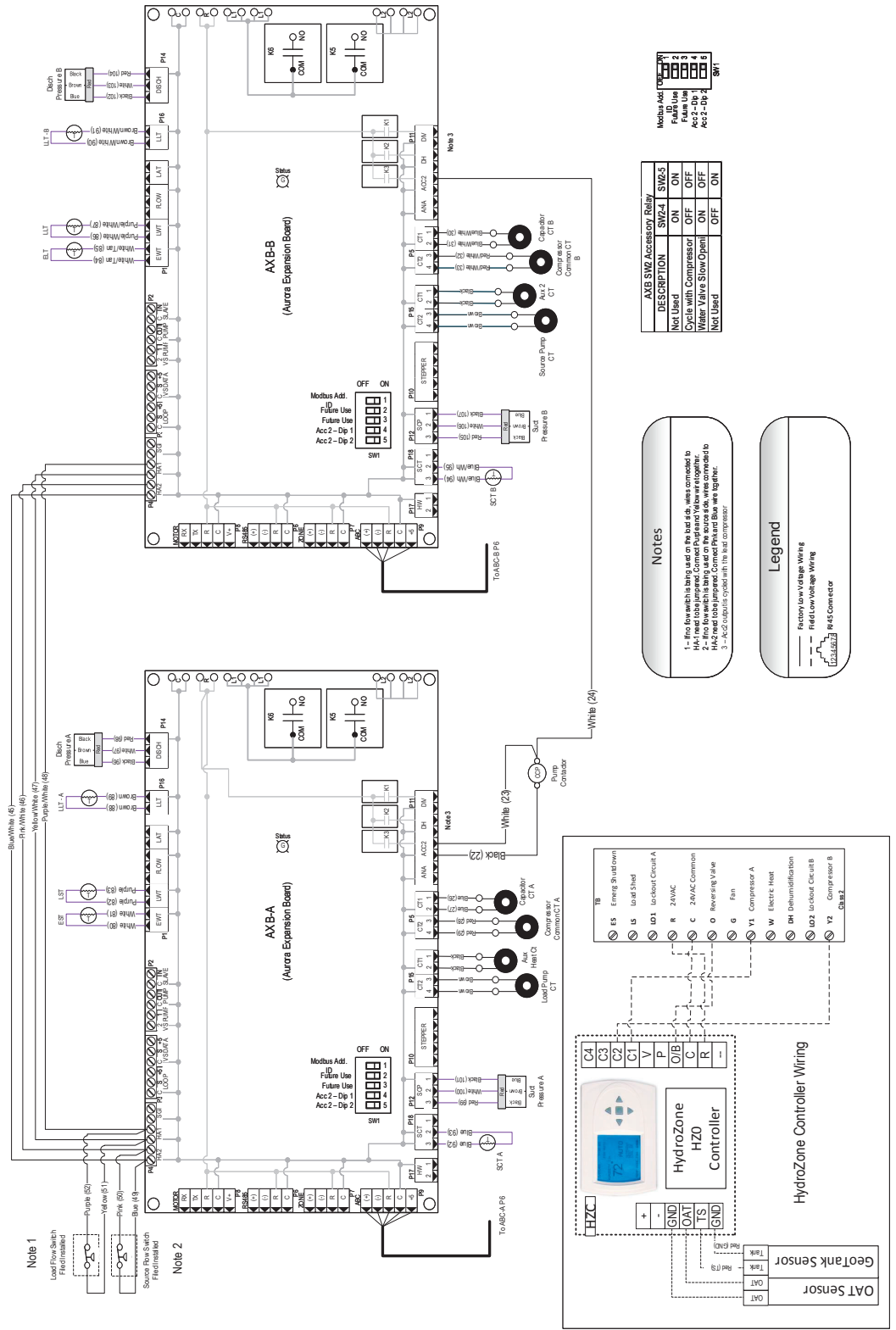

# Wiring Schematics cont.

## 208-230/60/1 with Soft Start Option and HydroZone

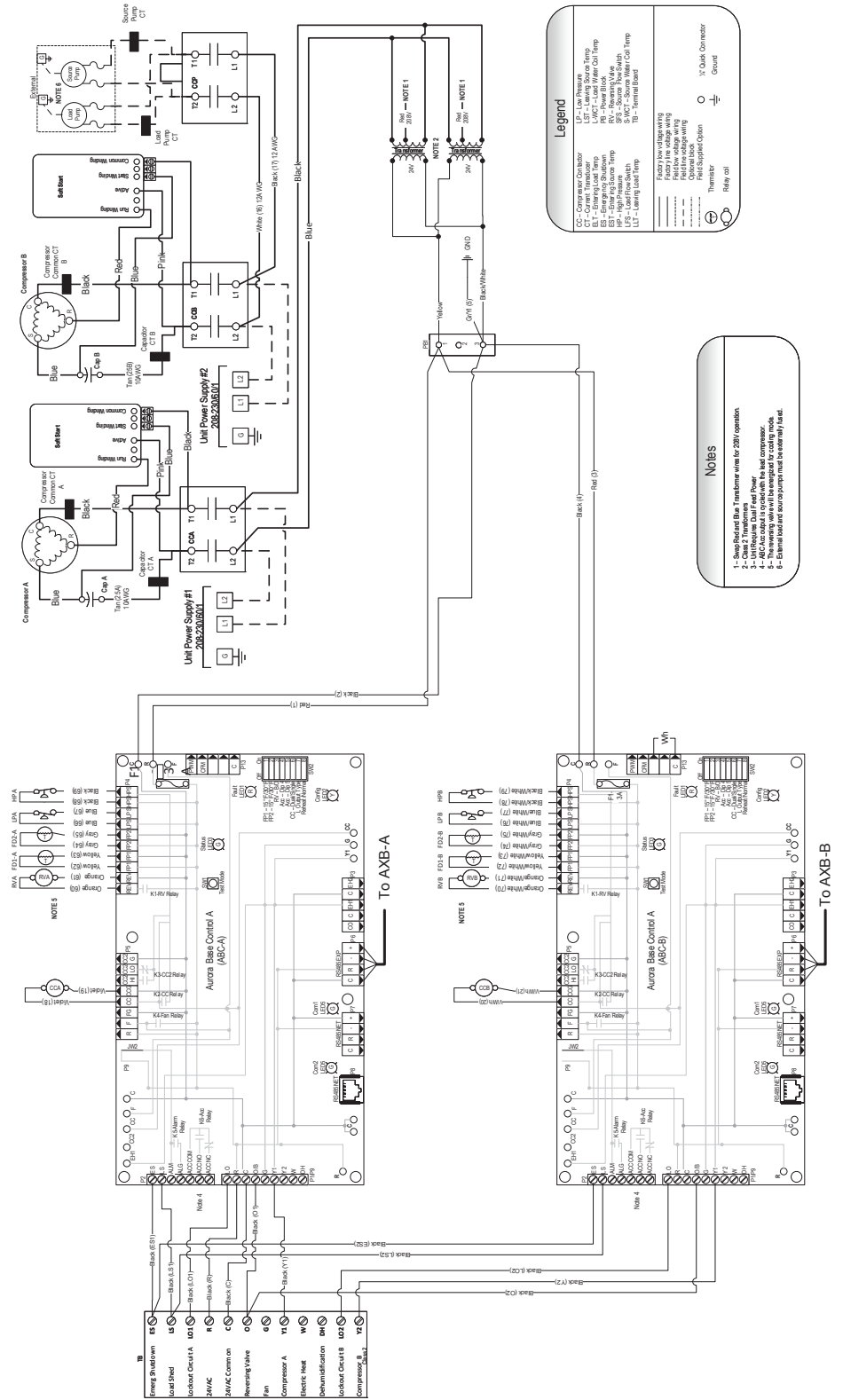



# Wiring Schematics cont.

## 208-230/60/1 Supply Power with HydroZone continued

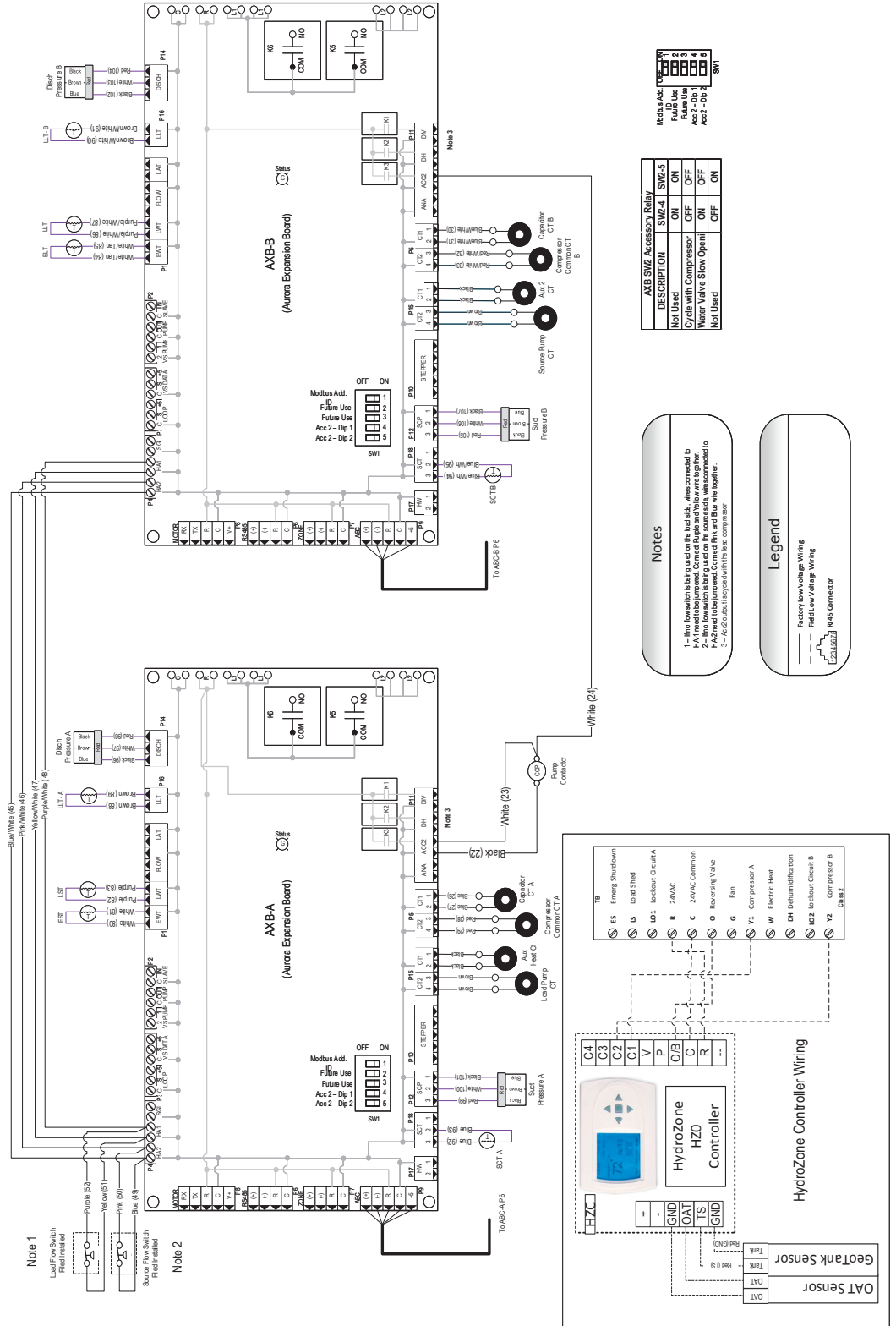

# Wiring Schematics cont.

## 3PH Supply Power with HydroZone

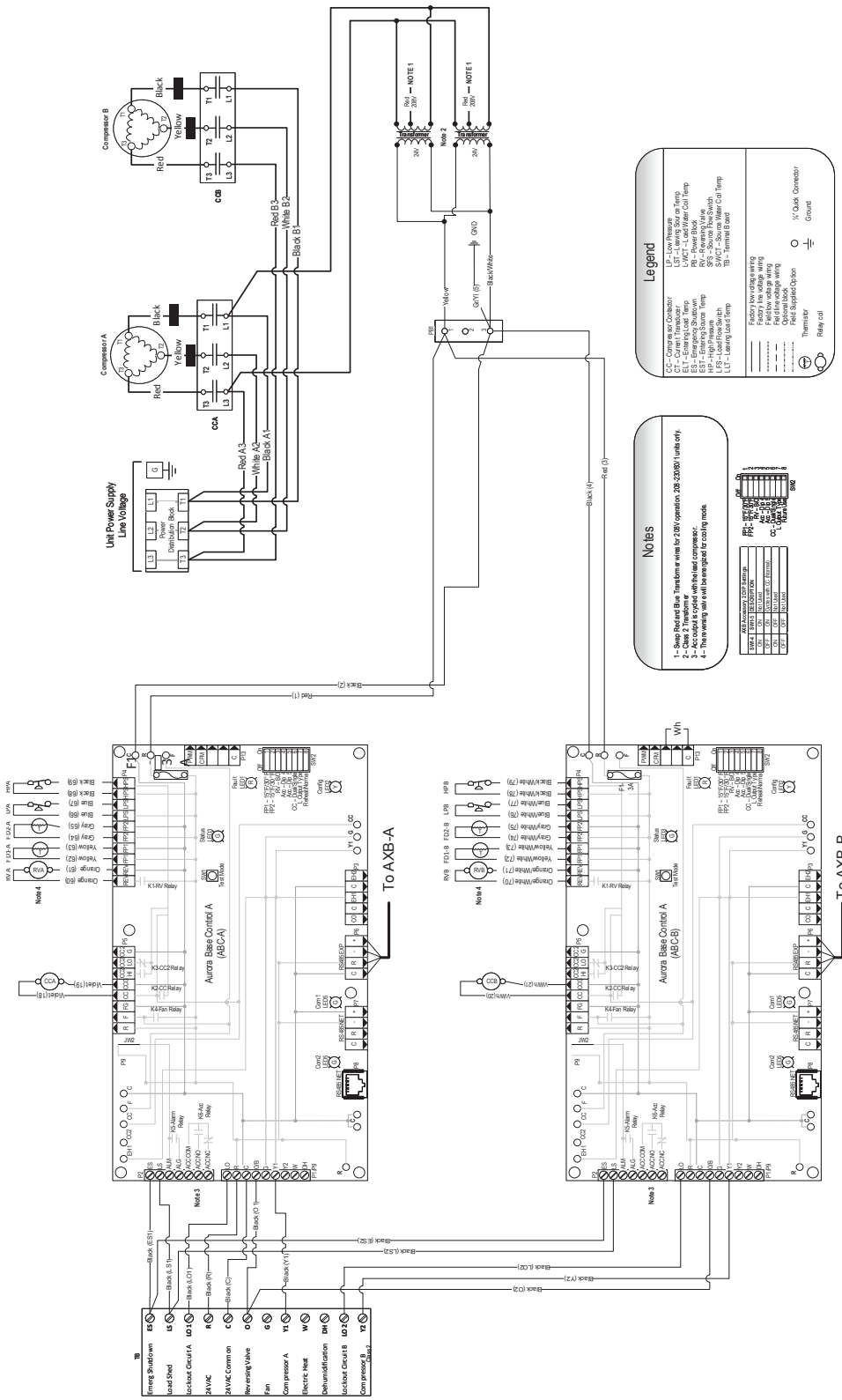

# Wiring Schematics cont.

## 3PH Supply Power with HydroZone continued

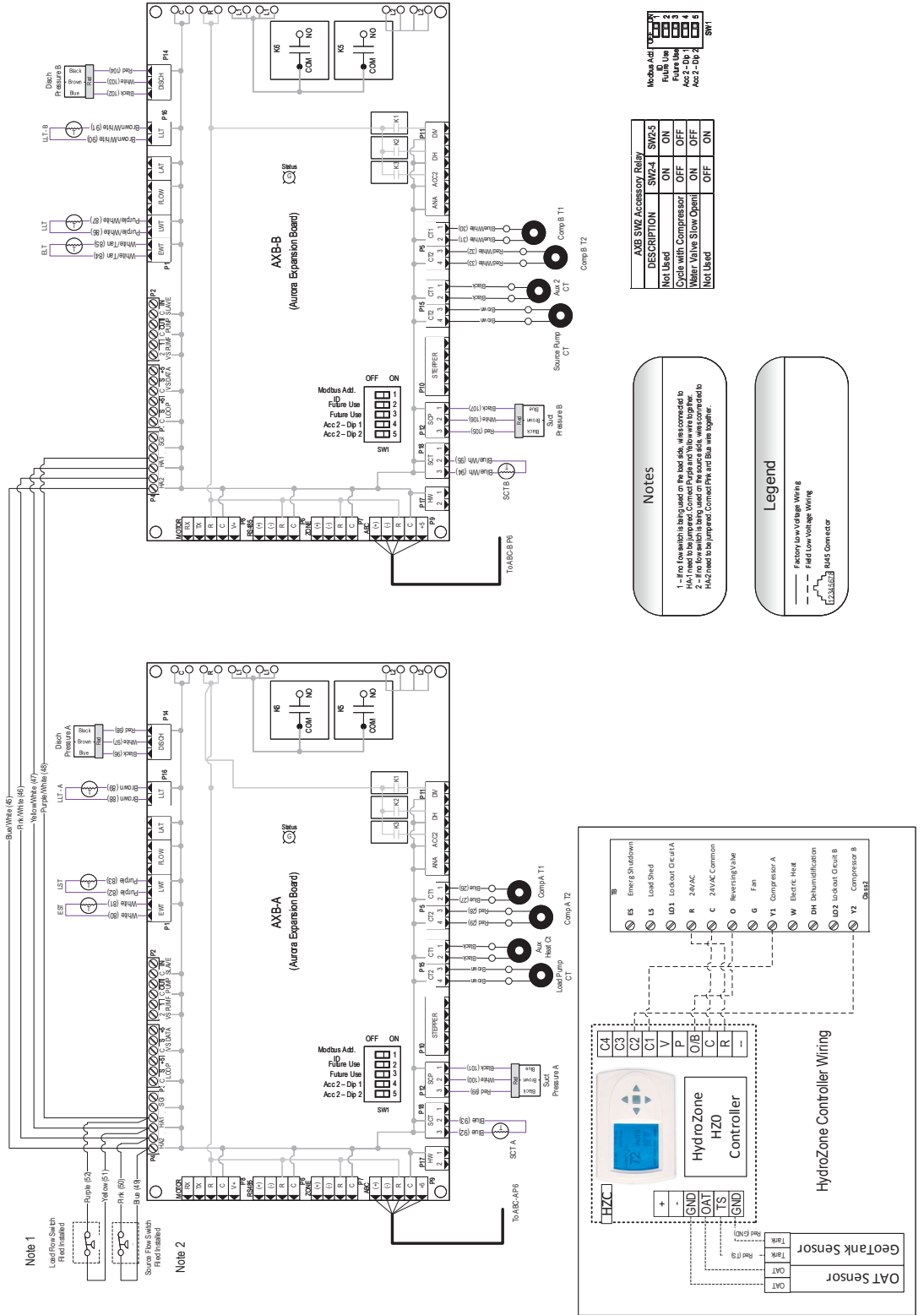



# Wiring Schematics cont.

## 100-180 208-230/60/1 with HydroLink continued

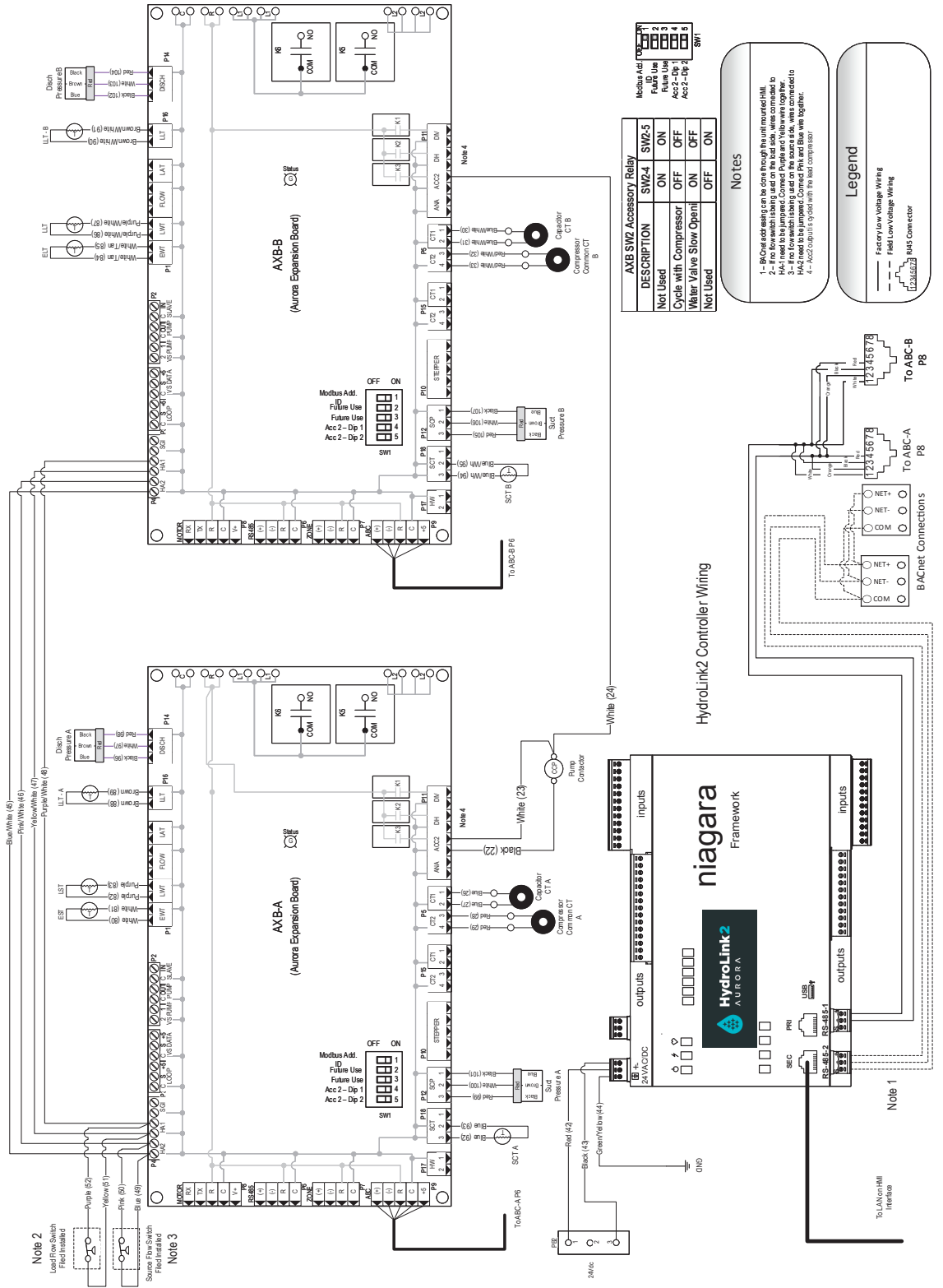

# Wiring Schematics cont.

## 100-180 208-230/60/1 with Soft Start Option and HydroLink

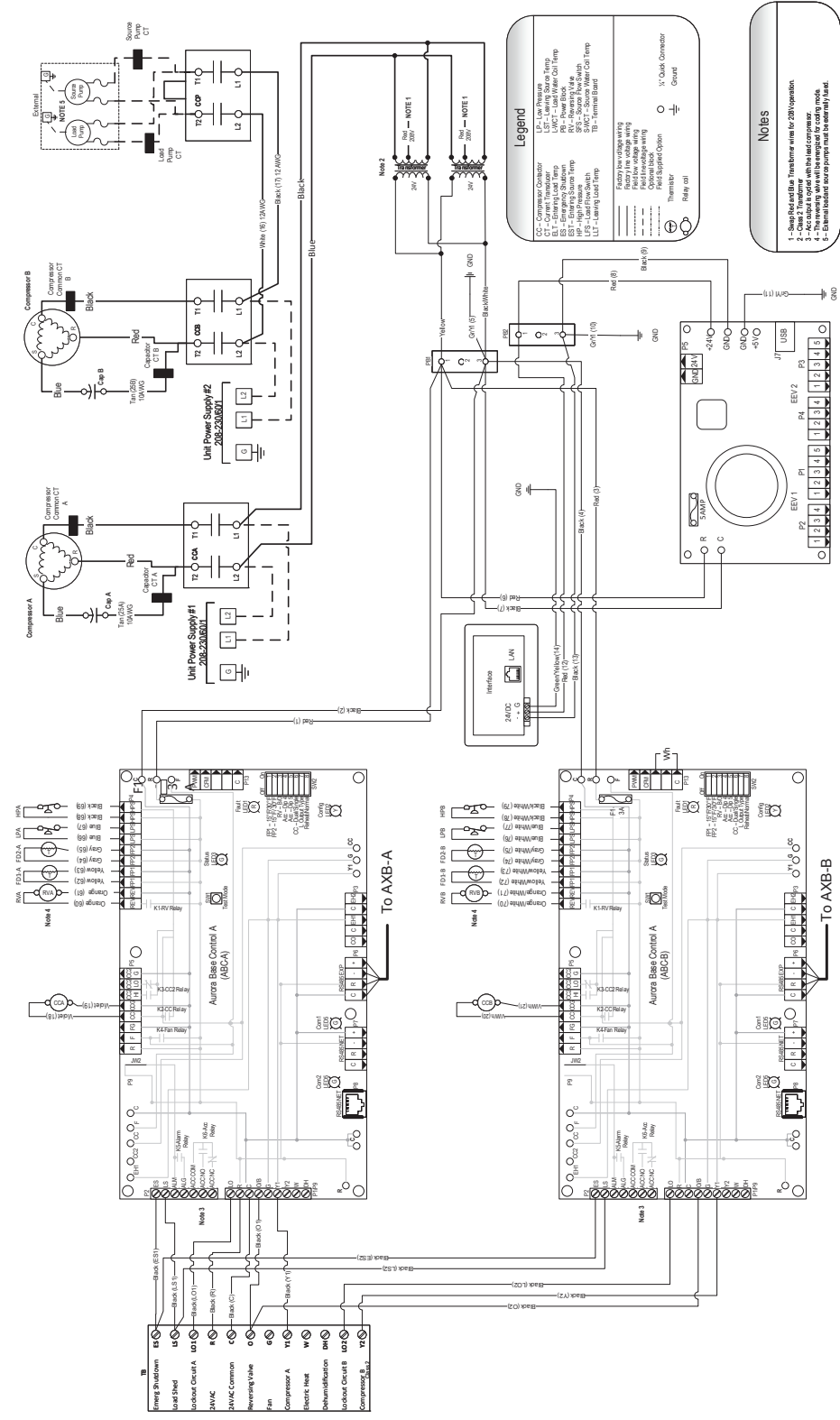

# Wiring Schematics cont.

## 100-180 208-230/60/1 with HydroLink continued

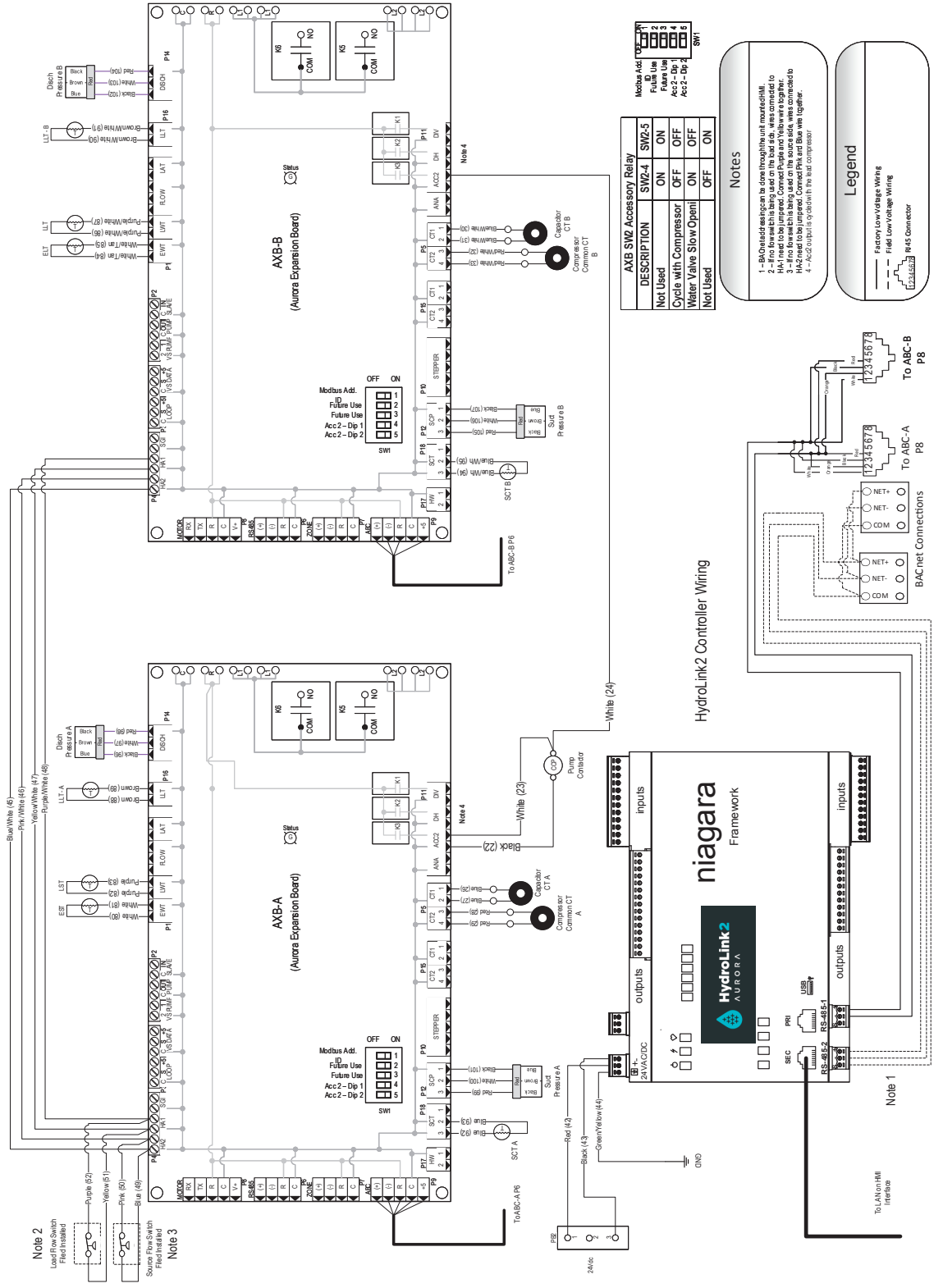

# Wiring Schematics cont.

## 3PH Supply Power HydroLink

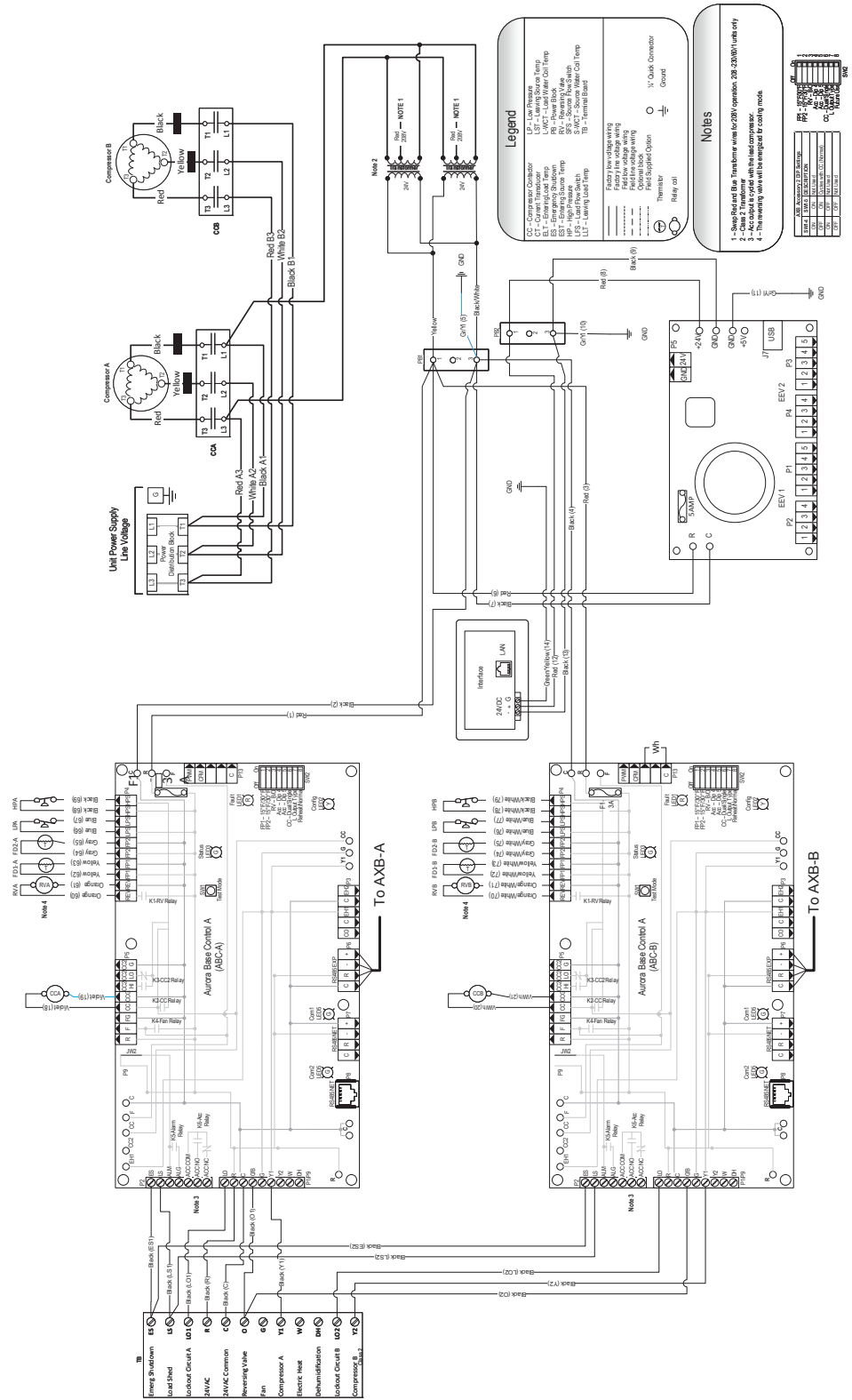



# Wiring Schematics cont.

## 3PH Supply Power HydroLink continued

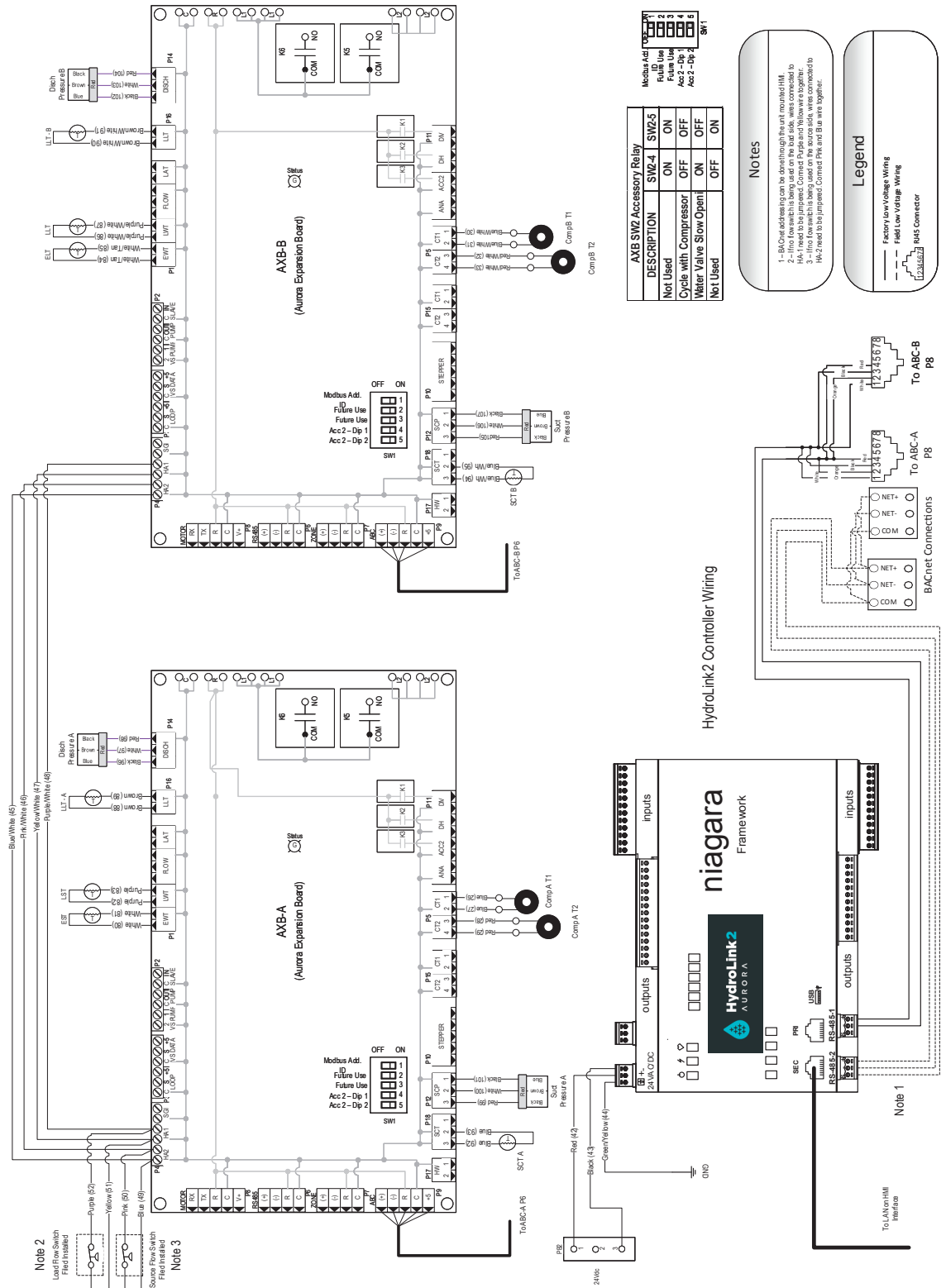

# The Aurora Base Control System

## Aurora ‘Base’ Control

The Aurora ‘Base’ Control (ABC) System is a complete residential and commercial comfort system that brings all aspects of the HVAC system into one cohesive module network. The ABC features microprocessor control and HP, LP, condensate and freeze detection, over/under voltage faults, along with communicating thermostat capability for complete fault detection text at the thermostat.

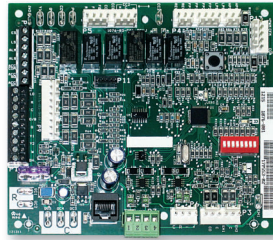

Aurora uses the Modbus communication protocol to communicate between modules. Each module contains the logic to control all features that are connected to the module. The Aurora ‘Base’ Control (ABC) has two Modbus channels. The first channel is configured as a master for connecting to devices such as a communicating thermostat, expansion board, or other slave devices. The second channel is configured as a slave for connecting the Aurora Interface Diagnostics Tool (AID Tool).

## Aurora ‘Advanced’ Control

The Aurora ‘Advanced’ Control expands on the capability of the Aurora ‘Base’ Control (ABC) System by adding the Aurora Expansion Board (AXB). The additional features include compressor current monitoring, loop pump linking, intelligent hot water generator control, variable speed pump capability, and also allows for optional energy, refrigeration, and performance monitoring factory installed add-on sensor kits. The AXB also features a second field configurable accessory relay, and two home automation inputs that are AID configurable for different types of alarms from sump pumps to home security. The Smart Grid input is AID configurable with many options to react to Utility controlled relay operation for ON Peak optimization.

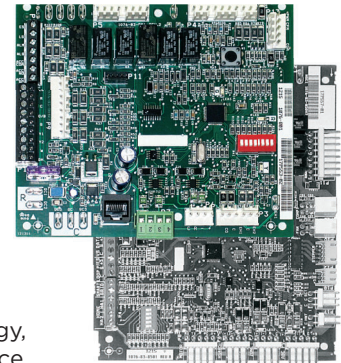

Aurora Control Features	Description	Aurora ‘Base’	Aurora ‘Advanced’
<b>Microprocessor Compressor Control</b>	Microprocessor control of compressor for timings with FP1, HP, LP, Condensate, assignable Acc relay	•	•
<b>Advanced Microprocessor Features</b>	Smart Grid, Home Automation Alarm Inputs, and Accessory2 Relay (HRV/ERV)	-	•
<b>Base Loop Pump Control</b>	Compressor Contactor powers Loop Pump and no loop pump linking capability.	•	See below
<b>Compressor Monitoring</b>	Control monitors compressor starts for high current, missing leg etc.	-	•
<b>Smart Grid/Utility Input</b>	Allows simple input to externally enable of occupied/unoccupied mode for basic utility time of use programs.	-	Dry Contact x1

## The Aurora Base Control System cont.

Service Device	Description	Aurora 'Base'	Aurora 'Advanced'
 <p><b>Aurora Interface and Diagnostics (AID) Tool</b></p>	<p>Allows setup, monitoring and troubleshooting of any Aurora Control.</p> <p><b>NOTE:</b> Although the ABC has basic compatibility with all Aurora, new product features may not be available on older AID Tools. To simplify the basic compatibility ensure the version of AID is at least the same or greater than the ABC software version.</p>	For Service (Ver. 1.xx or greater)	For Service (Ver. 2.xx or greater)

Add On Control Feature Kits (factory installed)	Description	Aurora 'Base'	Aurora 'Advanced'
<b>Geo Energy Monitoring Kit</b>	Monitors realtime power consumption of compressor, aux heat and pump. AXB required.	-	Standard
<b>Refrigeration Monitoring Kit</b>	Monitors realtime pressures, temperatures, superheat, and subcooling. AXB required.	-	Standard
<b>Performance Monitoring Kit</b>	Monitors water temperatures	-	Standard
<b>Data Logging (AWL) Kit</b>	Allows data logging of up to 12 months. Can also be temporarily installed for troubleshooting.	-	Optional

Add On Thermostats and Zoning	Description	Aurora 'Base'	Aurora 'Advanced'
<b>HZO</b>	Non-communicating controller for up to two heat pumps.	Standard	Standard

# The Aurora Base Control System cont.

## Aurora ‘Base’ Control

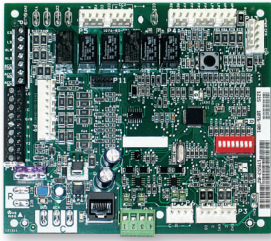

**NOTE:** Refer to the Aurora Base Control Application and Troubleshooting Guide and the Instruction Guide: Aurora Interface and Diagnostics (AID) Tool for additional information.

### Control Features

- Random start at power up
- Anti-short cycle protection
- High and low pressure cutouts
- Loss of charge
- Water coil freeze detection
- Over/under voltage protection
- Load shed
- Emergency shutdown
- Diagnostic LED
- Test mode push button switch
- Alarm output
- Accessory output with N.O. and N.C.
- Modbus communication

### Field Selectable Options via Hardware

**DIP Switch (SW1)** – Test/Configuration Button (See SW1 Operation Table)

#### Test Mode

The control is placed in the test mode by holding the push button switch SW1 for 2 - 5 seconds. In test mode most of the control timings will be shortened by a factor of sixteen (16). LED3 (green) will flash at 1 second on and 1 second off. Additionally, when entering test mode LED1 (red) will flash the last lockout one time. Test mode will automatically time out after 30 minutes. Test mode can be exited by pressing and holding the SW1 button for 2 to 5 seconds or by cycling the power. **NOTE:** Test mode will automatically be exited after 30 minutes.

#### Reset Configuration Mode

The control is placed in reset configuration mode by holding the push button switch SW1 for 50 to 60 seconds. This will reset all configuration settings and the EEPROM back to the factory default settings. LED3 (green) will turn off when entering reset configuration mode. Once LED3 (green) turns off, release SW1 and the control will reset.

### DIP Switch (SW2)

**SW2-1 (Source)** FP1 Selection – Low water coil temperature limit setting for freeze detection. On = 30°F; Off = 15°F.

**SW2-2 (Load)** FP2 Selection – On = 30°F; Off = 15°F

**SW2-3** RV – O/B - thermostat type. Heat pump thermostats with “O” output in cooling or “B” output in Heating can be selected. On = O; Off = B.

**SW2-4** Access Relay Operation (P2) and 2-5

Access Relay Operation	SW2-4	SW2-5
Cycle with Blower		n/a
Cycle with Compressor	OFF	OFF
Water Valve Slow Opening	ON	OFF
Cycle with Comm. T-stat Hum Cmd		n/a

**Cycle with Blower** - (Not used on water-to-water)

**Cycle with Compressor** - The accessory relay will cycle with the compressor output.

**Water Valve Slow Opening** - The accessory relay will cycle and delay both the blower and compressor output for 90 seconds.

**SW2-6** CC Operation – selection of single or dual capacity compressor. On = Single Stage; Off = Dual Capacity

**SW2-7** Lockout and Alarm Outputs (P2) – selection of a continuous or pulsed output for both the LO and ALM Outputs. On = Continuous; Off = Pulsed

**SW2-8** Future Use

### Alarm Jumper Clip Selection

From the factory, ALM is connected to 24 VAC via JW2. By cutting JW2, ALM becomes a dry contact connected to ALG.

### Field Selectable Options via Software

(Selectable via the Aurora AID Tool)

### Safety Features

The following safety features are provided to protect the compressor, heat exchangers, wiring and other components from damage caused by operation outside of design conditions.

**Fuse** – a 3 amp automotive type plug-in fuse provides protection against short circuit or overload conditions.

**Anti-Short Cycle Protection** – 4 minute anti-short cycle protection for the compressor.

**Random Start** – 5 to 80 second random start upon power up.

## The Aurora Base Control System cont.

**Fault Retry** - in the fault condition, the control will stage off the outputs and then “try again” to satisfy the thermostat Y input call. Once the thermostat input calls are satisfied, the control will continue on as if no fault occurred. If 3 consecutive faults occur without satisfying the thermostat Y input call, then the control will go to Lockout mode.

**Lockout** - The Alarm output (ALM) and Lockout output (L) will be turned on. The fault type identification display LED1 (Red) shall flash the fault code. To reset lockout conditions with SW2-8 On, thermostat inputs “Y1”, “Y2”, and “W” must be removed for at least 3 seconds. To reset lockout conditions with SW2-8 Off, thermostat inputs “Y1”, “Y2”, “W”, and “DH” must be removed for at least 3 seconds. Lockout may also be reset by turning power off for at least 30 seconds or by enabling the emergency shutdown input for at least 3 seconds.

**High Pressure** - fault is recognized when the Normally Closed High Pressure Switch, P4-9/10 opens, no matter how momentarily. The High Pressure Switch is electrically in series with the Compressor Contactor and serves as a hard-wired limit switch if an overpressure condition should occur.

**Low Pressure** - fault is recognized when the Normally Closed Low Pressure Switch, P4-7/8 is continuously open for 30 seconds. Closure of the LPS any time during the 30 second recognition time restarts the 30 second continuous open requirement. A continuously open LPS shall not be recognized during the 2 minute startup bypass time.

**Loss of Charge** - fault is recognized when the Normally Closed Low Pressure Switch, P4-7/8 is open prior to the compressor starting.

**Freeze Detection (Source Coax)** - set points shall be either 30°F or 15°F. When the thermistor temperature drops below the selected set point, the control shall begin counting down the 30 seconds delay. If the thermistor value rises above the selected set point, then the count should reset. The resistance value must remain below the selected set point for the entire length of the appropriate delay to be recognized as a fault. This fault will be ignored for the initial 2 minutes of the compressor run time.

**Freeze Detection (Load Coax)** - uses the FP2 input to protect against ice formation on the coax. The FP2 input will operate exactly like FP1.

**Over/Under Voltage Shutdown** - An over/under voltage condition exists when the control voltage is outside the range of 18 VAC to 30 VAC. If the over/under voltage shutdown lasts for 15 minutes, the lockout and alarm relay will be energized. Over/under voltage shutdown is self-resetting in that if the voltage comes back within range of 18 VAC to 30 VAC for at least 0.5 seconds, then normal operation is restored.

### Operation Description

**Power Up** - The unit will not operate until all the inputs and safety controls are checked for normal conditions. The unit has a 5 to 80 second random start delay at power up. Then the compressor has a 4 minute anti-short cycle delay after the random start delay.

**Standby** In standby mode, Y1, Y2, W, DH, and G are not active. Input O may be active. The compressor will be off.

### Heating Operation

**Heating, 1st Stage (Y1)** - The compressor is energized 10 seconds after the Y1 input is received.

### Cooling Operation

In all cooling operations, the reversing valve directly tracks the O input. Thus, anytime the O input is present, the reversing valve will be energized.

**Cooling, 1st Stage (Y1, O)** - The compressor is energized 10 seconds after the Y1 input is received.

**Emergency Shutdown** - Four (4) seconds after a valid ES input, P2-7 is present, all control outputs will be turned off and remain off until the emergency shutdown input is no longer present. The first time that the compressor is started after the control exits the emergency shutdown mode, there will be an anti-short cycle delay followed by a random start delay. Input must be tied to common to activate.

**Load Shed** - The LS input disables all outputs with the exception of the blower output. When the LS input has been cleared, the anti-short cycle timer and random start timer will be initiated. Input must be tied to common to activate.

# The Aurora Base Control System cont.

## Aurora ‘Base’ Control LED Displays

These three LEDs display the status, configuration, and fault codes for the control. These can also be read in plain English via the Aurora AID Tool.

### Status LED (LED3, Green)

Description of Operation	Fault LED, Green
Normal Mode	ON
Control is Non-functional	OFF
Test Mode	Slow Flash
Lockout Active	Fast Flash
Dehumidification Mode	Flash Code 2
(Future Use)	Flash Code 3
(Future Use)	Flash Code 4
Load Shed	Flash Code 5
ESD	Flash Code 6
(Future Use)	Flash Code 7

### Fault LED (LED1, Red)

Red Fault LED		LED Flash Code*	Lockout	Reset/Remove
ABC Basic Faults	Normal - No Faults	OFF	-	
	Fault - Input	1	No	Auto
	Fault - High Pressure	2	Yes	Hard or Soft
	Fault - Low Pressure	3	Yes	Hard or Soft
	Fault - Freeze Detection FP2	4	Yes	Hard or Soft
	Fault - Freeze Detection FP1	5	Yes	Hard or Soft
	Fault - Condensate Overflow	7	Yes	Hard or Soft
	Fault - Over/Under Voltage	8	No	Auto
	Fault - FP1 & FP2 Sensor Error	11	Yes	Hard or Soft

**NOTE:** All codes >11 use long flash for tens digit and short flash for the ones digit. 20, 30, 40, 50, etc. are skipped.

## ABC Control Board Layout

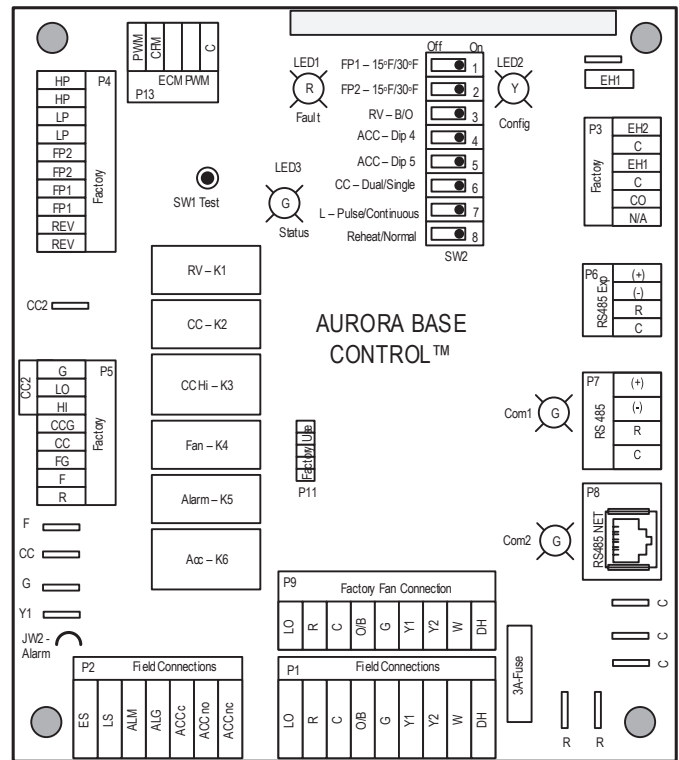

## Aurora Interface and Diagnostics (AID) Tool

The Aurora Interface and Diagnostics (AID) Tool is a device that is a member of the Aurora network. The AID Tool is used to troubleshoot equipment which uses the Aurora control via Modbus RTU communication. The AID Tool provides diagnostics, fault management, ECM setup, and system configuration capabilities to the Aurora family of controls. An AID Tool is recommended, although not required, for ECM airflow settings. The AID Tool simply plugs into the exterior of the cabinet in the AID Tool port.





## The Aurora Base Control System cont.

### Aurora ‘Advanced’ Control Features

The Aurora ‘Advanced’ Control system expands on the capability of the Aurora ‘Base’ Control (ABC) by adding the Aurora Expansion Board (AXB). All of the preceding features of the Aurora ‘Base’ Control are included. The following control description is of the additional features and capability of the Aurora advanced control.

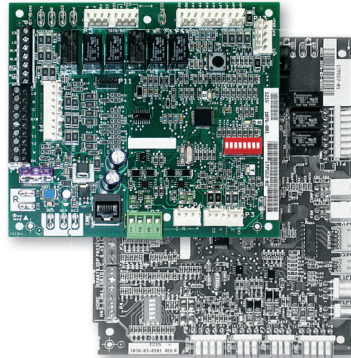

It is highly recommended the installing/servicing contractor obtain an Aurora Interface and Diagnostic Tool (AID) and specialized training before attempting to install or service an Aurora ‘Advanced’ control system.



The additional AXB features include the following:

### AXB DIP Switch

**DIP 1 - ID:** This is the AXB ModBus ID and should always read On.

**DIP 2 & 3 - Future Use**

**DIP 4 & 5 - Accessory Relay2:** A second, DIP configurable, accessory relay is provided that can be cycled with the compressor 1 or 2 , blower, or the Dehumidifier (DH) input. This is to complement the Accessory 1 Relay on the ABC board.

Position	DIP 4	DIP 5	Description
1	ON	ON	Cycles with Fan or ECM (or G)
2	OFF	ON	Cycles with CC1 first stage of compressor or compressor spd 6
3	ON	OFF	Cycles with CC2 second stage of compressor or compressor spd 7-12
4	OFF	OFF	Cycles with DH input from ABC board

### Compressor Monitoring

The AXB includes two current transducers to monitor the compressor current and starting characteristics. Open circuits or welded contactor faults will be detected. A fault will produce an E10 code.

### Advanced Communication Ports

Communication ports P6 and P8 will provide future expansion via dedicated protocols. These are for future use.

## The Aurora Base Control System cont.

---

### Smart Grid-On Peak (SG) Input

The 'On Peak' input was designed to allow utilities to utilize simple radio controlled switches to control the On Electric Peak behavior of the 5 and 7 Series Geothermal Heat Pumps. With a closed contact signal, this input will limit the operation and thus the power consumption of the unit by one of the below selections. The AID Tool will allow configuration of this input for the action of:

- No Action
- Disable compressor operation until removed
- Go to On Peak thermostat settings until removed [Requires Com T-Stat] (Future Release)
- Compressor limited to 50% or low cap until removed [dual capacity or variable speed only] (Future Release)
- Disable compressor operation for 1/2 hr (can be removed immediately) (Future Release)

Then Flash Code 7 on the Green LED for the 'On Peak' mode. And On Peak will display on communicating thermostats.

### Monitoring Sensor Kits

#### Energy Monitoring (Standard Sensor Kit)

The Energy Monitoring Kit includes four current transducers (source pump, load pump, auxiliary heat 1 and auxiliary heat 2) added to the existing four compressor sensors for compressor A and compressor B so that the complete power usage of the heat pump can be measured. The AID Tool provides a line voltage calibration procedure to improve the accuracy, and a power adjustment setting that allows the compressor power to be adjusted to match the units line voltage using the provided tables. This information can be displayed on the AID Tool.

#### Refrigerant Monitoring

The Refrigerant Monitoring Kit includes two pressure transducers, and three temperature sensors, heating liquid line, suction temperature and existing cooling liquid line (FPI). These sensors allow the measurement of discharge and suction pressures, suction and liquid line temperatures as well as superheat and subcooling. This information will only be displayed on the AID Tool.

#### Performance Monitoring

The Performance Monitoring Kit includes three temperature sensors, entering and leaving source, and leaving load water.



## The Aurora Base Control System cont.

### Aurora ‘Advanced’ Control LED Displays

These three LEDs display the status, configuration, and fault codes for the control. These can also be read in plain English via the Aurora AID Tool.

#### Status LED (LED3, Green)

Description of Operation	Fault LED, Green
Normal Mode	ON
Control is Non-functional	OFF
Test Mode	Slow Flash
Lockout Active	Fast Flash
Dehumidification Mode	Flash Code 2
Load Shed	Flash Code 5
Emergency Shutdown	Flash Code 6
On Peak Mode	Flash Code 7
(Future Use)	Flash Code 8
(Future Use)	Flash Code 9

#### Configuration LED (LED2, Yellow)

Description of Operation	Configuration LED, Yellow
No Software Overwritten	ECM Setting
DIP Switch Overwritten	Slow Flash
ECM Configuration Mode	Fast Flash
Reset Configuration Mode	OFF

#### Fault LED (LED1, Red)

	Red Fault LED	LED Flash Code *	Lockout	Reset/Remove	Fault Condition Summary
ABC Basic Faults	Normal - No Faults	Off	-		
	Fault-Input	1	No	Auto	Tstat input error. Autoreset upon condition removal.
	Fault-High Pressure	2	Yes	Hard or Soft	HP switch has tripped (>600 psi)
	Fault-Low Pressure	3	Yes	Hard or Soft	Low Pressure Switch has tripped (<40 psi for 30 continuous sec.)
	Fault-Freeze Detection FP2	4	Yes	Hard or Soft	Freeze protection sensor has tripped (<15 or 30 degF for 30 continuous sec.)
	Fault-Freeze Detection FP1	5	Yes	Hard or Soft	Freeze protection sensor has tripped (<15 or 30 degF for 30 continuous sec.)
	Fault-Condensate Overflow	7	Yes	Hard or Soft	Condensate switch has shown continuity for 30 continuous sec.
	Fault-Over/Under Voltage	8	No	Auto	Instantaneous voltage is out of range. **Controls shut down until resolved.
ABC & AXB Advanced Faults	Fault-FP1 Snsr Error	11	Yes	Hard or Soft	If FP1 Sensor Error
	Fault-Compressor Monitor	10	Yes	Hard or Soft	Open Crkt, Run, Start or welded cont
	Non-CriticAXBSnsrErr	13	No	Auto	Any Other Sensor Error
	CriticAXBSnsrErr	14	Yes	Hard or Soft	Sensor Error for EEV or HW
	Alert-HotWtr	15	No	Auto	HW over limit or logic lockout. HW pump deactivated.
	Fault-VarSpdPump	16	No	Auto	Alert is read from PWM feedback.
	Not Used	17	No	Auto	IZ2 Com Fault. Autoreset upon condition removal.
	Non-CritComErr	18	No	Auto	Any non-critical com error
	Fault-CritComErr	19	No	Auto	Any critical com error. Auto reset upon condition removal
	Alarm - Low Loop Pressure	21	No	Auto	Loop pressure is below 3 psi for more than 3 minutes
	Alarm - Home Automation 1	23	No	Auto	Closed contact input is present on Dig 2 input - Text is configurable
	Alarm - Home Automation 2	24	No	Auto	Closed contact input is present on Dig 3 input - Text is configurable

**NOTES:**

\*All codes >11 use long flash for tens digit and short flash for the ones digit. 20, 30, 40, 50 etc. are skipped!

Alert’ is a noncritical sensor or function that has failed. Normal operation of the heat pump is maintained but service is desired at some point.

## HydroZone Controller Instructions

### Installation Instructions

The WaterFurnace HydroZone controller is a part of the hydronic heat pump system. The WaterFurnace part number for this product is HZC. This controller is a human interface and **water tank** control device.

The controller displays and regulates the water tank temperature, but not the conditioned space. A 2-1/2" x 2-1/2" LCD display and five push button keys serve as the human interface. The five keys are: the up and down keys (▲ and ▼) for changing the selection or temperature, the right and left keys (◀ and ▶) for changing the selection or mode, and the enter key (■) is for accepting and/or saving the selection.

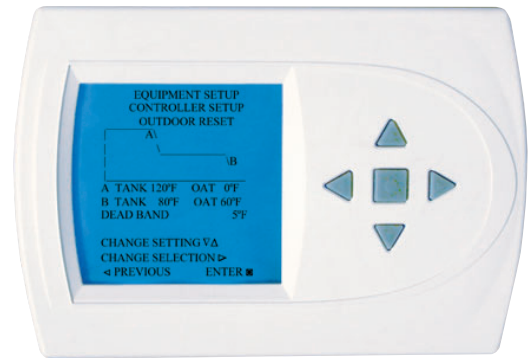

Figure 1

### Controller Operation

#### Adjusting Temperature

1. To select a MODE, use the keypad arrows to scroll to MODE. Then, press the enter button on the key pad to enter the operating mode menu.
2. Select the desired mode by scrolling up or down, with the arrows. **Then press the enter button on the keypad to enter into that mode.**
3. You are now returned to the Main Menu and Figure 1 is a similar view. **NOTE: Outdoor air temperature is only displayed if an outdoor air sensor is installed.**
4. To increase the temperature set point, use the arrow up button. To decrease the set point, use the arrow down button. Five (5) seconds after the last button push, the new setpoint is saved. **Outdoor reset control is done in the installer's setup and cannot be adjusted from the front screen.**

#### Setting Date And Time

1. From the Main Menu, scroll to MENU and press the enter button ■ on the keypad.
2. Select SET DATE.
3. SET MONTH by using the up and down arrows ▲▼. Then press the enter button ■ on the keypad to save the month.
4. SET DAY by using the up and down arrows ▲▼. Then press the enter button ■ on the keypad to save the day.
5. SET YEAR by using the up and down arrows ▲▼. Then press the enter button ■ on the keypad to save the year.
6. Select SET TIME.
7. SET HOUR by using the up and down arrows ▲▼. Then press the enter ■ button on the keypad to save the hour.
8. SET MINUTE by using the up and down arrows ▲▼. Then press the enter button ■ on the keypad to save the minute.
9. If your area observes daylight savings time, select AUTO DAYLIGHT SAVING; scroll to ON, then press the enter button ■ to save. You will be returned to the SET DATE AND TIME menu. Scroll to SET DATE AND TIME and press the enter button ■ on the keypad.
10. The date and time are now set. You can return to the Main Menu by pressing the left arrow key to return to the previous menu.

#### Changing Modes

1. From the main screen select MODE.
2. Select the operating mode you need and press the enter button ■.
 

**NOTE: If selecting EMERGENCY HEAT, the backlight color will change from blue to red indicating that auxiliary heat is operating instead of the heat pump compressor. Auxiliary/emergency heat is significantly more expensive to operate than the heat pump compressor, and should not be selected unless the heat pump compressor is not operational.**

#### Fahrenheit or Celsius

1. From the Main Menu, scroll to MENU and press the enter button ■ on the keypad.
2. Select FAHRENHEIT/CELSIUS.
3. Select which scale you prefer.

## HydroZone Controller Instructions cont.

### Backlight on Time

This controller has a two color backlight feature. Anytime a button is pressed, the blue backlight stays on for a certain amount of time. A red backlight is visible if you are selecting Emergency Heat mode. You can adjust the amount of time the backlight stays on in the menu options.

1. From the Main Menu, scroll to MENU and press the center button ■ on the keypad.
2. You can change the backlight on time by using the up and down arrows ▲▼. BACKLIGHTING ON (all the time), 15 sec., 30 sec., and NO BACKLIGHTING are your choices. Press the enter ■ button to save the new backlight on time.

## Advanced Settings

### Security Lockout

This controller has the option to set security features to lockout everything but the adjustment of the temperature or a total keypad lockout.

1. From the Main Menu, scroll to MENU and press the enter button ■ on the keypad.
2. Select LOCK/UNLOCK.
3. The selection will bring you to the Enter Pin Number screen.
4. Using the up and down arrows ▲▼, select a pin number to lock out the thermostat. The right arrow ► moves you to the next pin digit.
5. Once you've entered the 4-digit pin number, press the enter button ■ to save the pin. The screen will display LOCKED and return to the main Screen.
6. Once you return to the Main Screen, in the upper left of the screen will alternate between LOCKED and the date and time.
7. Once unlocked, you will have to reset a pin number again to lockout the thermostat again.
8. In the event the pin number is lost, the default is 9999.

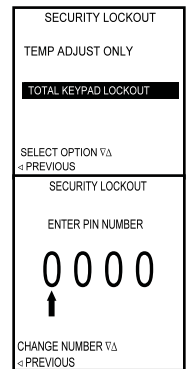

## Installer Information and Advanced Features

### Safety Considerations

Improper wiring or installation may damage the controller. Wiring must conform to local and national electrical codes.

### Introduction

The controller is a low-voltage controller which maintains geo storage tank temperature by controlling the operation of multiple hydronic heat pumps system. Batteries are not required; temperature and mode settings are preserved with the power off. The controller is not a power stealing device and MUST have both R and C connected. This controller does not regulate temperature in the conditioned space.

### HydroZone Installation

1. Turn off all power to unit.
2. Separate the front and back pieces of the HZO.
3. Mount the base of the HZO.
4. Connect wires to proper terminal on the pump relay. (see wiring schematic 97P806-01 on page 7)
5. Replace the cover on the base.
6. Turn on power to the unit.

**NOTE:** If the unit is connected to a Geo-Tank that does not have a tank water temperature sensor. Tank sensor kit GTANKTSK is shipped with the unit. This kit includes a bung fitting and well point thermistor.

# HydroZone Controller Instructions cont.

## Main Screen

After exiting from the setup mode, controller displays the main screen.

OPERATION, displays the current controller setup selection. They are OUTDOOR, TANK CONTROL AUTO, and TANK CONTROL MANUAL MODE. If the operation mode is outdoor reset or tank control auto, the MODE should display OFF, ON, or EHEAT. If the operation mode is tank control manual, the MODE should display OFF, HEAT, COOL, or EMHT. OUTPUT shall display the current status of the outputs (WARM WEATHER SHUTDOWN, STANDBY, C1, C2, C3, C4, or AUX). STANDBY mode is active when the controller is satisfied and waiting for a call. C1, C2, C3, and C4 will be off and O will stay in its previous state. If the outputs are off due to a warm weather shutdown condition, the proper message should be displayed.

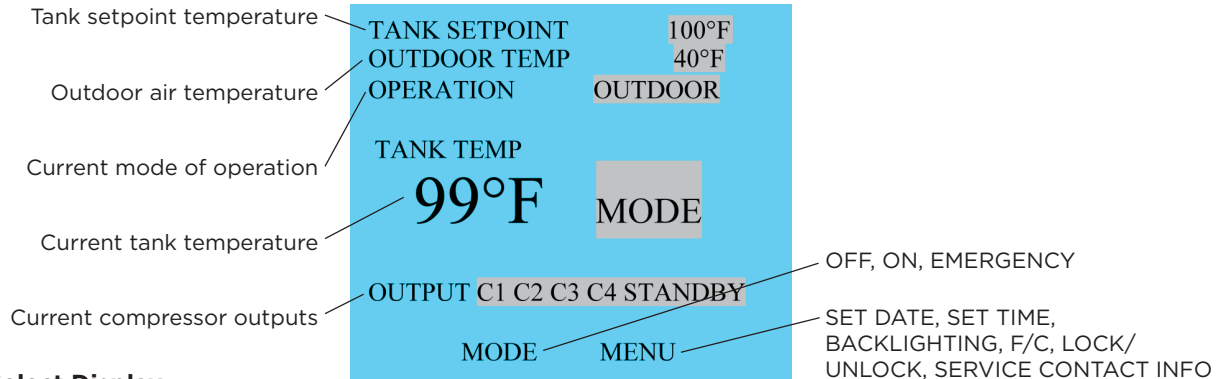

## Mode Select Display

Manual Tank Control Display

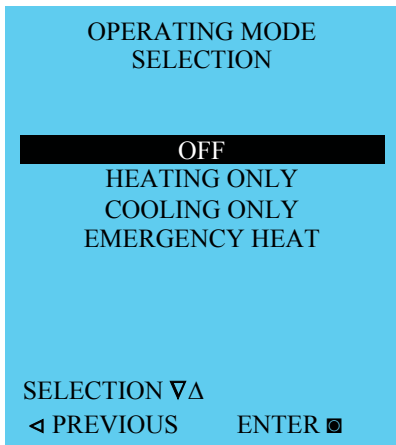

Outdoor Reset or Tank Auto Control

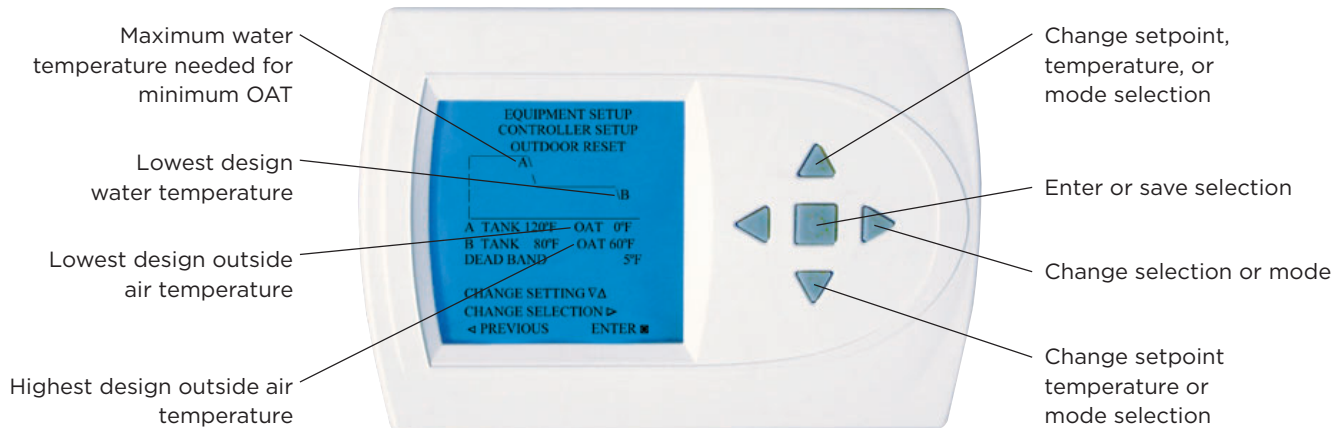
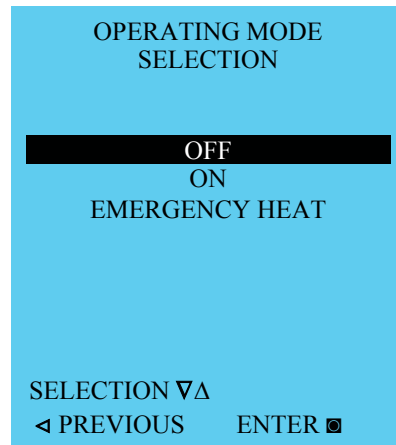

# HydroZone Controller Instructions cont.

## Wiring Schematic

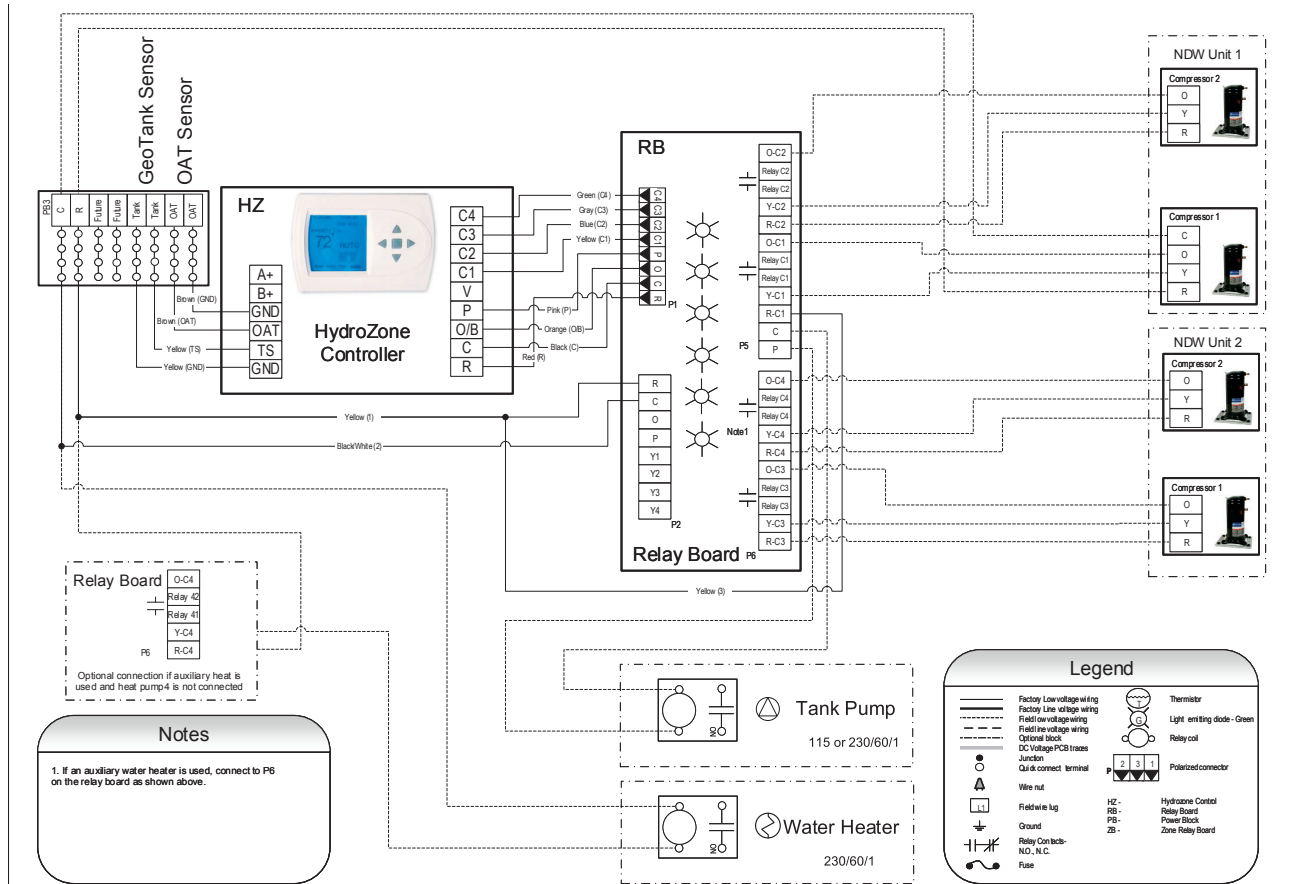

**Notes**

1. If an auxiliary water heater is used, connect to P6 on the relay board as shown above.

## Installer Settings

These options are intended to be used by the installer. End users are not advised to change or modify any of these settings. Doing so may make your equipment stop working properly and/or may void the warranty of the controller as well as the equipment hooked up to the controller. To access the installer setting menu, the mode must be set to OFF. **Then, press both the up and down arrow keys at the same time for at least 5 seconds to enter the installer screen.** After initial power-up, you re-enter installer setup. If no selection is made within 30 seconds, the controller will return to the main screen.

### Controller Setup

Options to select from:

- Outdoor Reset - This control mode uses the outdoor reset algorithm to continuously adjust the set point. The set up menu allows selection of Maximum Tank Temperature at a corresponding outdoor air temperature (OAT), and Minimum Tank Temperature at its corresponding OAT. **An outdoor air sensor must be installed.**

Set point A is the maximum tank temperature set point:

Tank temperature (TANK\_A) range is 100°F to 130°F (up to 150°F on NHW), and default as 120°F.

Outdoor air temperature (OAT) range is 0°F to 20°F, and default as 0°F.

Set point B is the minimum tank temperature set point:

Tank temperature (TANK\_B) range is 70°F to 90°F, and default as 80°F.

Outdoor air temperature (OAT) range is 40°F to 60°F, and default as 60°F.

**EQUIPMENT SETUP  
CONTROLLER SETUP  
OUTDOOR RESET**

A \

B

A TANK 120°F OAT 0°F  
B TANK 80°F OAT 60°F  
DEAD BAND 5°F

CHANGE SETTING ∇Δ  
CHANGE SELECTION ►  
◀ PREVIOUS ENTER ◻

## HydroZone Controller Instructions cont.

All these temperature settings are with increments of 1°F. The dead band is 2°F to 15°F with increments of 1°F.

Tank Temperature Set point is calculated internally by the outdoor reset algorithm, and updated every 30 minutes if this setup is selected.

### Warm Weather Shutdown:

If the warm weather shutdown is selected, the controller will check the outdoor air temperature sensor every 30 minutes. If the temperature is higher than the set temperature selected for 50 continuous hours, then the HydroZone Controller will enter the warm weather shutdown mode. If the temperature drops below the selected setpoint for 5 continuous hours, the controller will exit the warm weather shutdown mode and return back to normal. Warm weather shutdown selections are None, 45, 50, 55, 60, and 65. The factory default is None.

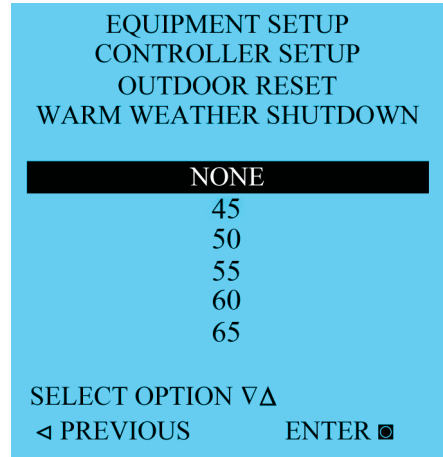

2. Tank Control Auto - This function will put the heat pump in cooling or heating to control to a **single** tank setpoint (default is 120°F). This feature is **not** an auto-changeover control of the conditioned space. If both heating and cooling are desired in the **conditioned space**, then heating and cooling will need to be selected manually with their own tank setpoints in the Tank Control Manual screen. Default temperature for tank setpoint is 120°F with a 5°F deadband. The set range is 40°F to 130°F (up to 150°F on NHW), with increments of 1°F. The dead band is 2°F to 5°F with increments of 1°F. The setpoint can be changed from the main screen by pushing the UP or DOWN buttons.

Selecting ENTER shall take the screen to the CONTROLLER SETUP screen.

This option will maintain the temperature with a tighter deadband and automatically switch the heat pump between heating and cooling to maintain a single setpoint. The factory default is 120°F heating and 5°F dead band.

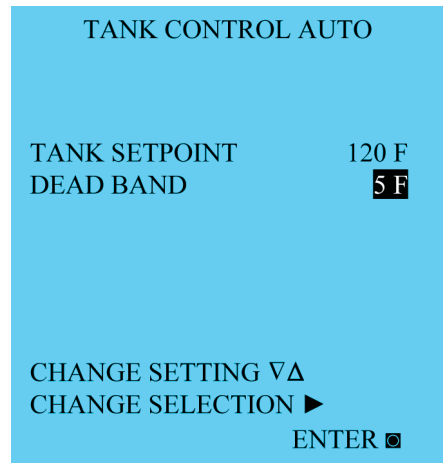

3. Tank Control Manual - There shall be no automatic changeover from heating to cooling or vice versa. Heating and cooling modes must be selected manually.

If heating fixed is selected, the default temperature for tank setpoint is 120°F with a 10°F deadband. The set range is 80°F to 130°F (up to 150°F on NHW), with increments of 1°F. The dead band is 2°F to 15°F with increments of 1°F. The factory defaults are 120°F heating and 5°F dead band, 80°F cooling and 5°F dead band, and warm weather shutdown is None. When the selection is moved to WARM WEATHER SHUTDOWN..., ENTER shall take the screen to the WARM WEATHER SHUTDOWN screen.

When ENTER is selected, the installer shall be taken to the COOLING screen.

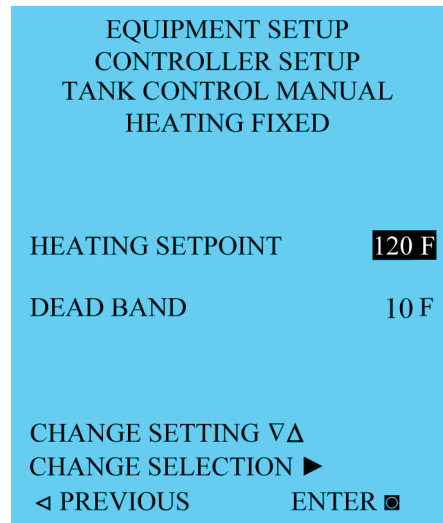

## HydroZone Controller Instructions cont.

If no heating is selected, the screen shall go to the COOLING screen.

If cooling fixed is selected, the default temperature for tank setpoint is 80°F with a 10°F deadband. The set range is 40°F to 85°F, with increments of 1°F. The dead band is 2°F to 15°F with increments of 1°F.

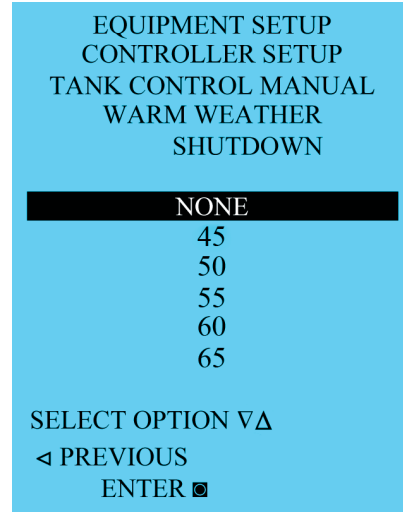
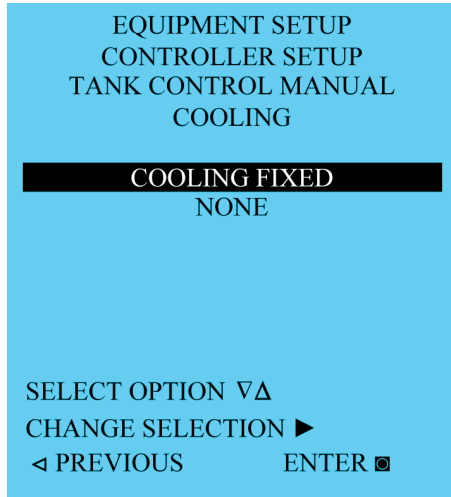

### Staging

The controller can control up to four stages of compressors or three compressors and one auxiliary heat. How the unit stages the outputs will be determined by how the outputs are configured. When selecting a dual capacity unit, the next available stage will automatically become dual stage 2. Example: If DUAL 1 STG 1 has been selected for C1 then C2 will automatically be DUAL 1 STG 2.

Staging Screen

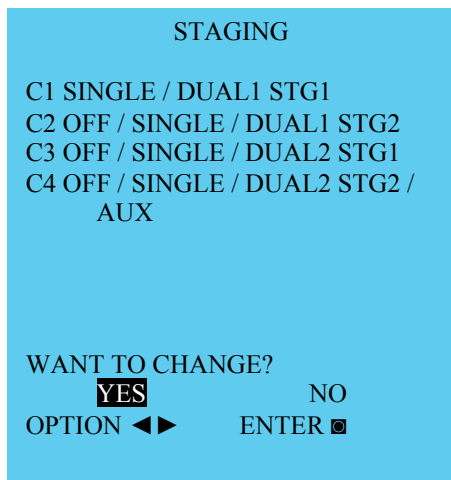

Staging Setup of 1 Dual Compressor and 1 Single with Aux Enabled

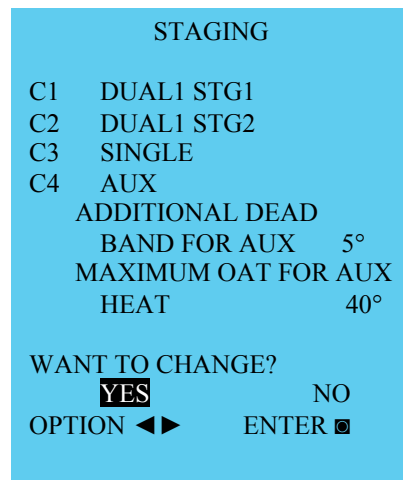

Output	Setup Configuration Options				Factory Defaults
C1	Single	Dual1 Stage1			Single
C2	Single	Dual1 Stage2	Off		Off
C3	Single	Dual2 Stage1	Off		Off
C4/W	Single	Dual2 Stage2	Aux	Off	Off

## HydroZone Controller Instructions cont.

If AUX is selected in stage 4, ENTER would take the user to “ADDITIONAL DEAD BAND FOR AUX HEAT” screen and then to “MAXIMUM OAT FOR AUX HEAT” screen.

The “ADDITIONAL DEAD BAND FOR AUX HEAT” would enable the installer to select how much extra dead band should be added on top of the heat dead band before auxiliary heat would come on. The range is between 5° and 15°F.

In the “MAXIMUM OAT FOR AUX HEAT” the installer can select between NONE or a certain outdoor air temperature. If the installer selects a certain temperature for OAT, the AUX heat shall not come on if the outdoor air temperature is above that temperature. The range is between 0°F and 40°F.

If “NONE” is selected, the AUX heat can come on at any time regardless of the outdoor air temperature. **An outdoor air sensor (TSU02) must be installed for this option.**

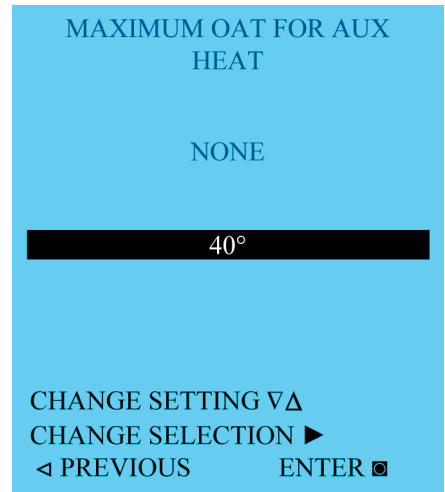

### Lead/Lag

If only C1 is selected in the staging, the lead/lag will be selected as “NO”, and can not be changed.

Each compressor output will have an accumulator to keep track of total run time. If any accumulator ran up to the maximum count, all the accumulators shall be reset. Total run time will be reset when lead/lag “NO” is selected. The default setting is “NO”.

- First On - Compressor stage with least amount of accumulated run time.
- First Off - Compressor stage with most amount of accumulated run time.

### Factory Defaults

When YES is selected for RESTORE FACTORY DEFAULTS, the controller will restore the factory defaults configuration. Factory default control option is tank control manual. The factory defaults are 120°F heating, 5°F dead band, and warm weather shutdown None.

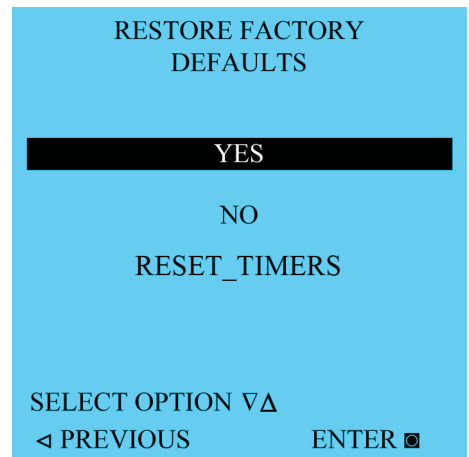



# HydroZone Controller Instructions cont.

## Service Contact Information

Input dealer info.

INPUT DEALER INFO

**BRAND NAME**

MODEL NUMBER

SERIAL NUMBER

CONTRACTOR NAME

CONTRACTOR PHONE

SAVE

SELECT OPTION  $\nabla\Delta$

$\triangleleft$  PREVIOUS                      ENTER

DEALER INFO

BRAND NAME:

USE  $\nabla\Delta$  TO SCORLL  
THRU CHARACTERS

**W**ATER FURNACE

-----

CHANGE LETTER  $\nabla\Delta$

$\triangleleft$  PREVIOUS                      ENTER

When the installer selects ENTER from any of the BRAND NAME, MODEL NUMBER, SERIAL NUMBER, CONTRACTOR NAME, and CONTRACTOR PHONE screens, the main INPUT DEALER INFO screen is shown. In order to save the dealer information in the permanent memory, the installer shall select SAVE from the main INPUT DEALER INFO screen and hit ENTER. The following screen is shown summarizing the information the installer has inserted in the previous screens.

BRAND NAME  
WATER FURNACE

MODEL NUMBER  
NSW018

SERIAL NUMBER  
A2345678

CONTRACTOR NAME  
JOHN SMITH

CONTRACTOR PHONE  
###-###-####

$\triangleleft$  PREVIOUS                      SAVE

## HydroZone Parts List

Part Number	Quantity	Description
96P697-01	1	Mass Label Sheet
12P546-01	1	8 Position Terminal Block
45C394-01	1	Control Box
45C394-02	1	Control Box Cover
11P813-00	1	Wire Kit
91P001A18	6	Screw #6-32 X 5/8
17P554-01	1	HydroZone Controller
17P555-01	1	Low Voltage Relay Board
91P001A43	4	Screw #10-24 X 3/8
91P008A12	1	Nut #10-32

## Reference Calculations

---

Heating Calculations: $LWT = EWT - \frac{HE}{GPM \times 500^*}$	Cooling Calculations: $LWT = EWT + \frac{HR}{GPM \times 500^*}$
--	--

**NOTE:** \* When using water. Use 485 for 15% methanol/water or Environol solution.

## Legend and Notes

---

### Abbreviations and Definitions

ELT = entering load fluid temperature to heat pump LLT = leaving load fluid temperature from heat pump LGPM = load flow in gallons per minute LWPD = load heat exchanger water pressure drop EST = entering source fluid temperature to heat pump LST = leaving source fluid temperature from heat pump SGPM = source flow in gallons per minute SWPD = source heat exchanger water pressure drop EER = cooling energy efficiency (TC/KW)	PSI = pressure drop in pounds per square inch FT HD = pressure drop in feet of head KW = kilowatt HR = heat rejected in MBTUH TC = total cooling capacity in MBTUH COP = coefficient of performance (HC/KW x 3.413) HC = heating capacity in MBTUH HE = heat of extraction in MBTUH
---	--

## Unit Startup

### Verify the following:

- High voltage is correct and matches nameplate
- Fuses, breakers and wire size are correct
- Low voltage wiring is complete
- Piping is complete and the water system has been cleaned and flushed
- Air is purged from closed loop system
- Isolation valves are open and water control valves or loop pumps are wired
- Service/access panels are in place
- Transformer has been switched to lower voltage tap if needed (208/230 volt units only)
- Unit controls are in “off” position
- Flow switches are installed and ready
- Freeze detection setpoints have been set in the microprocessor



**WARNING: Verify ALL water controls are open and allow water flow PRIOR to engaging the compressor. Failure to do so can result in freezing the heat exchanger or water lines causing permanent damage to the unit.**

## Powering The Controls

### Initial Configuration of the Unit

Before operating the unit, apply power and complete the following Aurora Startup procedure for the controls configuration. An AID Tool is recommended for setup, configuration and troubleshooting, especially with an Aurora ‘Advanced’ Control. AID Tool version 2.05 or greater is preferred.

**Note:** The configuration will need to be done on both ABC-A and ABC-B control boards.

#### 1. Configure Aurora Screen

- a. In advanced controls - Confirm AXB is added and communicating.

#### 2. Aurora Setup Screen

- a. Sensor Kit Setup
  - i. Activate energy option - Load pump and Aux heat current sensor activation
  - ii. Line Voltage calibration - Voltmeter required to calibrate line voltage during heating or cooling. Refer to Line Voltage Calibration in this manual for more details.
- b. Smart Grid Setup - Select Action option for utility received on-peak signal'

## Configuring the Sensor Kits

The Aurora Advanced Control allows Refrigeration, Energy, and Performance Monitoring sensor kits. The following description is for field activation of a factory installation of the sensor kits.

### Energy Monitoring

#### **(Standard Sensor Kit on most ‘Advanced’ models)**

The Energy Monitoring Kit AXB-A includes two current transducers (load pump and AUX heat) added to the existing two compressor A sensors. Energy Monitoring Kit AXB-B includes two current transducers (source pump and AUX 2) added to the existing two compressor B sensors, so that the complete power usage of the heat pump can be measured. The AID Tool provides a line voltage calibration procedure to improve accuracy. This information can be displayed on the AID Tool. Ensure the Energy Kit has been enabled by accessing the ‘Sensor Kit Setup’ in the AID Tool and complete the following:

- a. Activate ‘Energy Option’ to activate the sensors for compressor (2), load/source and AUX/ AUX2 current.
- b. Line Voltage Calibration - Voltmeter required to calibrate line voltage during heating or cooling. Refer to Line Voltage Calibration in this manual for more details.
  - i. Turn on Unit in Heating or Cooling .
  - ii. Use multimeter at L1 and L2 to measure line voltage
  - iii. In the Sensor Kit Setup screen adjust the ‘Base Voltage’ to the nearest value to that is measured
  - iv. Then use the ‘Fine Adjust’ to select the exact voltage being measured at L1 and L2.
  - v. Exit ‘Sensor Setup’ Screen
- c. Energy monitoring can be read on the following component:
  - i. AID Tool - instantaneous information only

## Unit Startup cont.

### Refrigerant Monitoring

#### *(standard sensor kit)*

The Refrigerant Monitoring Kit for compressors A and B includes two pressure transducers, and three temperature sensors, heating liquid line(FP2), suction temperature and existing cooling liquid line (FP1). These sensors allow the measurement of discharge and suction pressures, suction and liquid line temperatures as well as superheat and subcooling. This information will only be displayed on the AID Tool. Ensure the Refrigerant Monitoring has been setup by accessing the ‘Sensor Kit Setup’ in the AID Tool and complete the following:

Once sensors are installed for discharge pressure, suction pressure, suction, liquid line cooling and liquid line heating no further setup is required.

- a. Turn on Unit in Heating or Cooling .
- b. Use the AID Tool to view the refrigerant performance in the ‘Refrigerant Monitor’ screen.
- c. Refrigerant monitoring can be read on any of the following components:
  - i. AID Tool - instantaneous information only

### Performance Monitoring

#### *(standard sensor kit)*

The Performance Monitoring Kit includes three temperature sensors, source entering and leaving water, load leaving water temperature. Performance monitoring can be read on the following component:

- i. AID tool - instantaneous information only

### Startup Steps

- Set thermostat control above cooling setpoint.
- Set thermostat control in cooling mode.
- Slowly reduce the control setting until both the compressor and water control valve/loop pumps are activated. Verify that the compressor is on and that the water flow rate is correct by measuring pressure drop through the heat exchanger and comparing to the Pressure Drop table. Check for correct rotation on three phase scroll compressors. Switch any two power leads at the L1, L2, and L3 line voltage termination block if incorrect.
- Perform a cooling capacity test by multiplying GPM x  $\Delta T$  x 485 (antifreeze/water). Use 500 for 100% water. Check capacity against catalog data at same conditions.
- Set control to “OFF” position.
- Leave unit “OFF” for approximately five (5) minutes to allow pressure to equalize.
- Adjust control below heating setpoint.
- Set control in “HEAT” position mode.
- Slowly increase the control setting until both compressor and water control valve/loop pumps are activated. The reversing valve should be heard changing over.
- Perform a heating capacity test by multiplying GPM x  $\Delta T$  x 485 (antifreeze/water). Use 500 for 100% water. Check capacity against catalog data at same conditions.
- Check for vibrations, noise and water leaks.
- Set system to maintain desired setpoint.
- Instruct the owner/operator of correct control and system operation.

## Operating Parameters

### Heating Mode

Entering Load Temp (°F)	Entering Source Temp (°F)	Suction Pressure (psig)	Discharge Pressure (psig)	Superheat (°F)	Subcooling (°F)
60	30	75-100	200-215	10-12	10-13
	50	100-125	200-215	12-14	8-12
	70	125-150	215-230	14-18	8-12
	90	150-165	230-255	25-30	8-12
80	30	75-100	285-300	10-12	10-13
	50	100-125	300-315	12-14	8-12
	70	125-150	315-330	14-18	8-12
	90	150-165	330-345	25-30	8-12
100	30	85-110	365-380	10-12	7-11
	50	110-135	385-400	12-14	7-11
	70	135-165	400-415	14-18	3-7
120	50	110-135	485-500	12-14	7-11
	70	135-165	500-515	14-18	3-7

NOTE: Operating data based on normal conditions with 3 gpm/ton for the load and source.

2/15/10

### Cooling Mode

Entering Load Temp (°F)	Entering Source Temp (°F)	Suction Pressure (psig)	Discharge Pressure (psig)	Superheat (°F)	Subcooling (°F)
50	30	80-90	140-175	15-20	3-6
	50	90-100	200-235	11-15	6-9
	70	100-110	250-285	11-15	9-12
	90	100-120	330-365	8-12	12-14
	110	110-130	430-465	8-12	14-19
70	30	80-90	150-185	15-20	3-6
	50	90-100	210-245	11-15	6-9
	70	100-110	260-295	11-15	9-12
	90	110-120	340-375	8-12	12-14
	110	110-140	440-485	8-12	14-19
90	30	80-90	150-185	15-20	3-6
	50	90-100	210-245	11-15	6-9
	70	100-110	260-295	11-15	9-12
	90	110-120	340-375	8-12	12-14
110	30	90-100	160-195	40-45	3-6
	50	110-130	220-255	30-40	6-9

NOTE: Operating data based on normal conditions with 3 gpm/ton for the load and source.

2/15/10

## Load and Source Pressure Drop

Model	gpm	Pressure Drop (psi)				
		30°F	50°F	70°F	90°F	110°F
100	15	1.0	0.8	0.5	0.3	0.1
	23	2.5	2.2	2.0	1.7	1.3
	30	3.8	3.6	3.3	3.1	2.4
	34	4.5	4.3	4.0	3.8	3.0
120	18	1.6	1.3	1.1	0.8	0.6
	28	3.4	3.2	2.9	2.7	2.1
	36	4.9	4.7	4.4	4.2	3.3
	40	5.6	5.4	5.1	4.9	3.9
150	21	2.1	1.9	1.6	1.4	1.0
	32	4.2	3.9	3.7	3.4	2.7
	42	6.0	5.8	5.5	5.3	4.2
	50	7.5	7.3	7.0	6.8	5.5
180	24	2.7	2.4	2.2	1.9	1.5
	36	4.9	4.7	4.4	4.2	3.3
	48	7.1	6.9	6.6	6.4	5.1
	60	9.3	9.1	8.8	8.6	7.0

3/9/09

## Thermistor and Compressor Resistance

Thermistor Temperature		Resistance in Ohms
°F	°C	
5	-15	758
14	-10	789
23	-5	822
32	0	855
41	5	889
50	10	924
59	15	960
68	20	997
77	25	1035
86	30	1074
95	35	1113
104	40	1153
113	45	1195
122	50	1237
131	55	1279
140	60	1323
149	65	1368
158	70	1413
167	75	1459
176	80	1506
185	85	1554
194	90	1602
203	95	1652
212	100	1702

2/15/10

Model	208-230/60/1		208-230/60/3	460/60/3	575/60/3
	Run	Start			
100	0.32	0.821	0.610	2.330	4.060
120	0.28	0.819	0.610	2.330	4.060
150	0.291	0.841	0.422	2.200	3.289
180	0.312	0.874	0.419	1.614	2.507

NOTE: Resistance values may vary ±7%.

2/15/10

## Heat of Extraction/Rejection Data

Model	Source gpm	Load gpm	EST °F	Heat of Extraction (HE)				Heat of Rejection (HR)			
				60°F	80°F	100°F	120°F	50°F	70°F	90°F	110°F
100	30	30	30	83.6	75.4	67.3	59.1	131.6	142.8	154.1	165.3
			50	1015.1	96.9	88.7	80.4	127.3	140.0	152.6	165.2
			70	126.7	118.3	110.0	101.7	123.1	137.1	151.2	N/A
			90	148.2	139.8	N/A	N/A	118.9	134.3	149.7	N/A
			110	Not Available				114.6	131.5	N/A	N/A
120	36	36	30	90.9	81.9	72.8	63.8	159.6	177.7	195.8	213.9
			50	115.2	106.2	97.2	88.2	157.1	175.4	193.7	212.0
			70	139.6	130.6	121.6	112.5	154.5	173.1	191.6	N/A
			90	164.0	154.9	N/A	N/A	152.0	170.7	189.5	N/A
			110	Not Available				149.4	168.4	N/A	N/A
150	42	42	30	112.4	95.6	78.8	62.0	206.4	246.9	287.4	327.9
			50	147.0	130.4	113.8	97.1	196.6	236.6	276.6	316.6
			70	181.6	165.2	148.7	132.3	186.7	226.2	265.8	N/A
			90	216.3	200.0	N/A	N/A	176.8	215.9	255.0	N/A
			110	Not Available				166.9	205.6	N/A	N/A
180	48	48	30	126.2	108.7	91.1	73.6	233.8	282.2	330.6	379.0
			50	166.3	146.9	127.4	108.0	224.3	267.6	310.9	354.2
			70	206.4	185.0	163.7	142.4	214.8	253.0	291.2	N/A
			90	246.5	223.2	N/A	N/A	205.2	238.3	271.4	N/A
			110	Not Available				195.7	223.7	N/A	N/A

3/7/13

## Heating Cycle Analysis

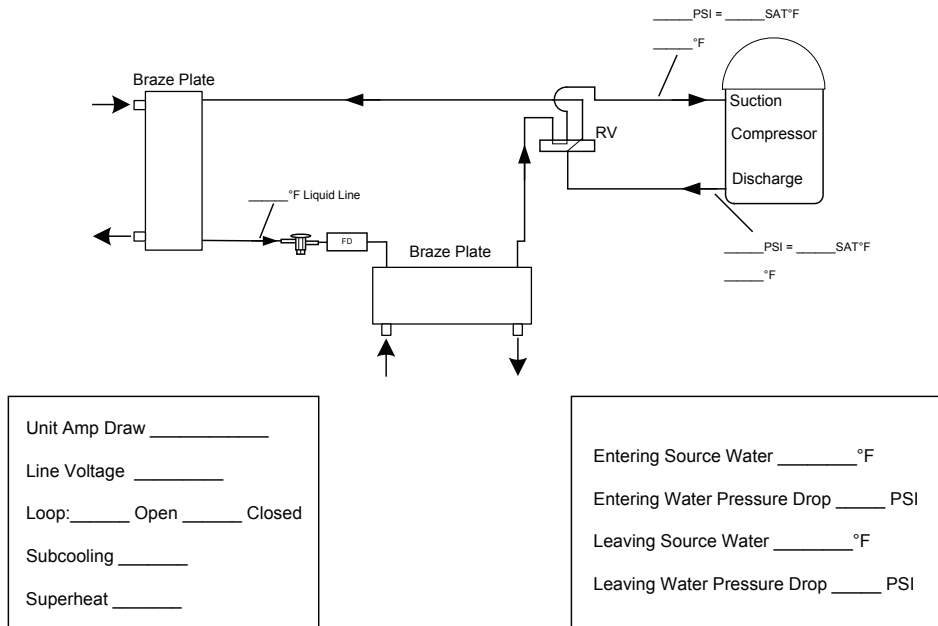

NOTE: Do not attach refrigerant gauges unless a problem is suspected!

## Cooling Cycle Analysis

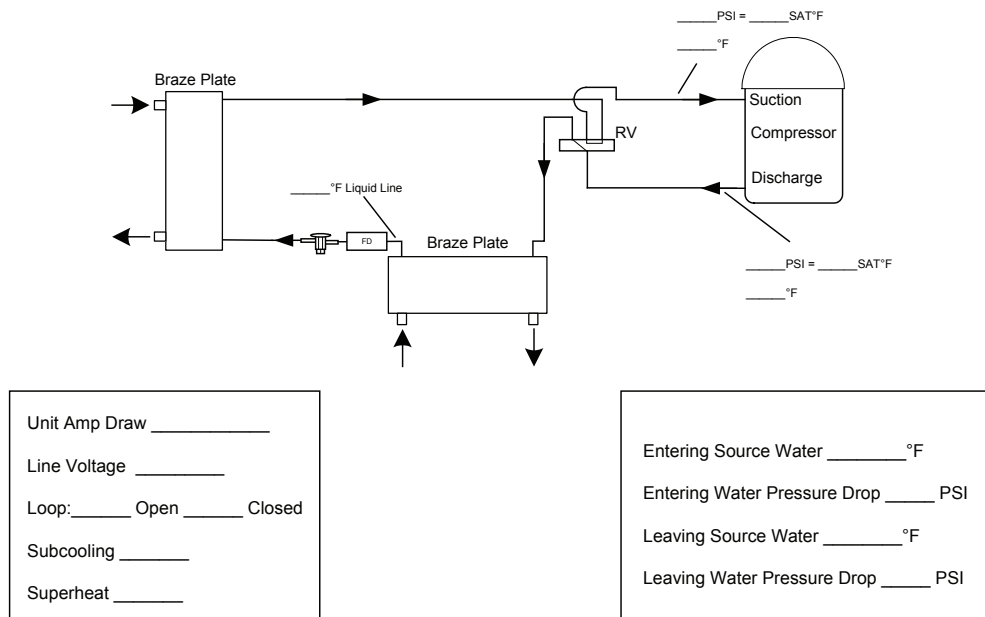

NOTE: Do not attach refrigerant gauges unless a problem is suspected!

# Startup and Troubleshooting Form

Company Name: \_\_\_\_\_ Company Phone No: \_\_\_\_\_  
 Technician Name: \_\_\_\_\_ Date: \_\_\_\_\_  
 Model No: \_\_\_\_\_ Serial No: \_\_\_\_\_  
 Owner's Name: \_\_\_\_\_ Open or Closed Loop: \_\_\_\_\_  
 Installation Address: \_\_\_\_\_ Installation Date: \_\_\_\_\_

Check One

Start up/Check-out for new installation     Troubleshooting    Problem: \_\_\_\_\_

1. FLOW RATE IN GPM (SOURCE SIDE HEAT EXCHANGER)

Water In Pressure: a. \_\_\_\_\_ PSI  
 Water Out Pressure: b. \_\_\_\_\_ PSI  
 Pressure Drop = a - b c. \_\_\_\_\_ PSI  
 Convert Pressure Drop to Flow Rate  
 (refer to *Pressure Drop* table) d. \_\_\_\_\_ GPM

2. TEMPERATURE RISE OR DROP ACROSS SOURCE SIDE HEAT EXCHANGER

	COOLING	HEATING
Water In Temperature:	e. _____ °F	e. _____ °F
Water Out Temperature:	f. _____ °F	f. _____ °F
Temperature Difference:	g. _____ °F	g. _____ °F

3. TEMPERATURE RISE OR DROP ACROSS LOAD SIDE HEAT EXCHANGER

	COOLING	HEATING
Water In Temperature:	h. _____ °F	h. _____ °F
Water Out Temperature:	i. _____ °F	i. _____ °F
Temperature Difference:	j. _____ °F	j. _____ °F

4. HEAT OF REJECTION (HR) / HEAT OF EXTRACTION (HE) CALCULATION

HR or HE = Flow Rate x Temperature Difference x Brine Factor\*  
 d. (above) x g. (above) x 485 for Methanol or Environol, 500 for water\*  
 Heat of Extraction (Heating Mode) = \_\_\_\_\_ btu/hr  
 Heat of Rejection (Cooling Mode) = \_\_\_\_\_ btu/hr  
 Compare results to Capacity Data Tables

Note: Steps 5 through 8 need only be completed if a problem is suspected

5. WATTS

	COOLING	HEATING	HYDRONIC
Volts:	m. _____ VOLTS	m. _____ VOLTS	m. _____ VOLTS
Total Amps (Comp. + Fan):	n. _____ AMPS	n. _____ AMPS	n. _____ AMPS
Watts = m. x n. x 0.85	o. _____ WATTS	o. _____ WATTS	o. _____ WATTS

6. CAPACITY

Cooling Capacity = HR. - (o. x 3.413)                      p. \_\_\_\_\_ btu/hr  
 Heating Capacity = HE. + (o. x 3.413)                      p. \_\_\_\_\_ btu/hr

7. EFFICIENCY

Cooling EER = p. / o.    q. \_\_\_\_\_ EER  
 Heating COP = p. / (o. x 3.413)                              q. \_\_\_\_\_ COP

8. SUPERHEAT (S.H.) / SUBCOOLING (S.C.)

	COOLING	HEATING	HYDRONIC
Suction Pressure:	r. _____ PSI	r. _____ PSI	r. _____ PSI
Suction Saturation Temperature:	s. _____ °F	s. _____ °F	s. _____ °F
Suction Line Temperature:	t. _____ °F	t. _____ °F	t. _____ °F
Superheat = t. - s.	u. _____ °F	u. _____ °F	u. _____ °F
Head Pressure:	v. _____ PSI	v. _____ PSI	v. _____ PSI
High Pressure Saturation Temp.:	w. _____ °F	w. _____ °F	w. _____ °F
Liquid Line Temperature*:	x. _____ °F	x. _____ °F	x. _____ °F
Subcooling = w. - x.	y. _____ °F	y. _____ °F	y. _____ °F

\* Note: Liquid line is between the source heat exchanger and the expansion valve in the cooling mode; between the load heat exchanger and the expansion valve in the heating mode.



## Troubleshooting

Should a major problem develop, refer to the following information for possible causes and corrective steps.

### If compressor won't run:

1. The fuse may be open or the circuit breaker is tripped. Check electrical circuits and motor windings for shorts or grounds. Investigate for possible overloading. Replace fuse or reset circuit breakers after fault is corrected.
2. Supply voltage may be too low. Check it with a volt meter.
3. Control system may be faulty. Check control for correct wiring of thermostat or aquastat and check the 24 volt transformer for proper voltage.
4. Wires may be loose or broken. Replace or tighten.
5. The low pressure switch may have tripped due to one or more of the following:
  - a) Heating
    - 1) Plugged heat exchanger on source side
    - 2) Water flow source side - (Low)
    - 3) Water too cold source side
    - 4) Low refrigerant
  - b) Cooling
    - 1) Plugged heat exchanger on load side
    - 2) Water flow load side - (Low)
    - 3) Water too cold load side
    - 4) Low refrigerant
6. The high pressure switch may have tripped due to one or more of the following:
  - a) Heating
    - 1) Plugged heat exchanger on load side
    - 2) Low water flow load side
    - 3) Water too warm load side
  - b) Cooling
    - 1) Plugged heat exchanger on source side
    - 2) Low water flow on source side
    - 3) Water too warm source side
7. The compressor overload protection may be open.
8. The internal winding of the compressor motor may be grounded to the compressor shell. If so, replace the compressor.
9. The compressor winding may be open or shorted. Disconnect power. Check continuity with ohm meter. If the winding is open, replace the compressor.

### If sufficient cooling or heating is not obtained:

1. Check control for improper location or setting.
2. Check for restriction in water flow.
3. Check refrigerant subcooling and superheat for proper refrigerant charge and expansion valve operation.
4. The reversing valve may be defective and creating a bypass of refrigerant. If the unit will not heat, check the reversing valve coil.

### If the unit operation is noisy:

1. Check compressor for loosened mounting bolts. Make sure compressor is floating free on its isolator mounts. Check for tubing contact with the compressor or other surfaces. Readjust it by bending slightly.
2. Check screws on all panels.
3. Check for chattering or humming in the contactor or relays due to low voltage or a defective holding coil. Replace the component.
4. Check for proper installation of vibration absorbing material under the unit.
5. Check for abnormally high discharge pressures.
6. Compressor rotation incorrect

## Preventive Maintenance

---

### Unit Heat Exchanger Maintenance

1. Keep all air out of the water or antifreeze solution.
2. Keep the system under pressure at all times. Closed loop systems must have positive static pressure or air vents may draw air into the system.

**NOTES:** If the installation is in an area with a known high mineral content in the water, it is best to establish with the owner a periodic maintenance schedule for checking the water-to-refrigerant heat exchanger on a regular basis. Should periodic cleaning be necessary, use standard cleaning procedures. Generally, the more water flowing through the unit, the less chance there is for scaling. Low GPM flow rates produce higher temperatures through the heat exchanger. To avoid excessive pressure drop and the possibility of metal erosion, do not exceed GPM flow rate as shown on the specification sheets for each unit.

### Replacement Procedures

When contacting the company for service or replacement parts, refer to the model number and serial number of the unit as stamped on the serial plate attached to the unit. If replacement parts are required, mention the date of installation of the unit and the date of failure, along with an explanation of the malfunctions and a description of the replacement parts required.

### In-Warranty Material Return

Material may not be returned except by permission of authorized warranty personnel. Contact your local distributor for warranty return authorization and assistance.

# Service Parts List

Part Description		NDW100				NDW120			
		208-230/60/1	208-230/60/3	460/60/3	575/60/3	208-230/60/3	208-230/60/3	460/60/3	575/60/3
Refrigeration Components	Compressor	34P580-01	34P580-03	34P580-04	34P580-05	34P616-01	34P616-03	34P616-04	34P616-05
	Compressor Sound Jacket	92P504A05				92P519-02			
	Thermal Expansion Valve	33P608-18				33P605-12			
	Filter Dryer	36P500B02				36P500B02			
	Reversing Valve with Coil	33P526-04				33P526-04			
	Brazed Plate Heat Exchanger	62P565-01				62P565-01			
	Heat Exchanger Support Bracket	47F588-01				47F588-01			
Safeties/Sensors	High Pressure Switch	35P506B02				35P506B02			
	Low Pressure Switch	35P506B01				35P506B01			
	Water Temperature Sensor	12P541-01				12P541-01			
	Refrigerant Temp Sensor	12P564-08				12P564-08			
Electrical	Compressor Contactor	13P004A03	13P537B03			13P004A03	13P537B03		
	Transformer	15P501B01	15P505B01	15P506B01		15P501B01	15P505B01	15P506B01	
	Power In Terminal Block	12P524A01				12P524A01			
	Connection Block - Small	12P503-06				12P503-06			
	Grounding Lug	12P004A				12P004A			
Control	ABC Board	17X553-12				17X553-12			
	AXB Board	17X557-14				17X557-14			
	24 DC Power Supply Board	17P568-02				17P568-02			
	HMI	19X641-13				19X641-13			
	HydroLink Controller	17X567-01				17X567-01			
Cabinet	Side Access Panel	40C661-01				40C661-01			
	Front/Back Access Panel	40C662-01				40C662-01			
	Access Panel (HMI Display)	40P662-10				40P662-10			
	Top Panel (back mount)	42C547-01				42C547-01			
	Top Panel - Large (top mount)	42C547-02				42C547-02			
	Top Panel - Small (top mount)	42C547-03				42C547-03			

12/09/20

Part Description		NDW150				NDW180			
		208-230/60/3	208-230/60/3	460/60/3	575/60/3	208-230/60/3	208-230/60/3	460/60/3	575/60/3
Refrigeration Components	Compressor	34P614-01	34P614-03	34P614-04	34P614-05	34P609-01	34P605-03	34P605-04	34P605-05
	Compressor Sound Jacket	92P519-02				92P519-02			
	Thermal Expansion Valve	33P605-13				33P605-14			
	Filter Dryer	36P500B02				36P500B02			
	Reversing Valve with Coil	33P526-04				33P526-04			
	Brazed Plate Heat Exchanger	62P565-01				62P565-01			
	Heat Exchanger Support Bracket	47F588-01				47F588-01			
Safeties/Sensors	High Pressure Switch	35P506B02				35P506B02			
	Low Pressure Switch	35P506B01				35P506B01			
	Water Temperature Sensor	12P541-01				12P541-01			
	Refrigerant Temp Sensor	12P564-08				12P564-08			
Electrical	Compressor Contactor	13P004A03	13P537B03			13P004A03	13P537B03		
	Transformer	15P501B01	15P505B01	15P506B01		15P501B01	15P505B01	15P506B01	
	Power In Terminal Block	12P524A01				12P524A01			
	Connection Block - Small	12P503-06				12P503-06			
	Grounding Lug	12P004A				12P004A			
Control	ABC Board	17X553-12				17X553-12			
	AXB Board	17X557-14				17X557-14			
	24 DC Power Supply Board	17P568-02				17P568-02			
	HMI	19X641-13				19X641-13			
	HydroLink Controller	17X567-01				17X567-01			
Cabinet	Side Access Panel	40C661-01				40C661-01			
	Front/Back Access Panel	40C662-01				40C662-01			
	Access Panel (HMI Display)	40P662-10				40P662-10			
	Top Panel (back mount)	42C547-01				42C547-01			
	Top Panel - Large (top mount)	42C547-02				42C547-02			
	Top Panel - Small (top mount)	42C547-03				42C547-03			

12/09/20



## Revision Guide

---

<b>Pages:</b>	<b>Description:</b>	<b>Date:</b>	<b>By:</b>
7	Updated Factory Charge in Physical Data	17 Jan 2023	MA
Misc	Removed FX10, Updated for "A" revision	29 Nov 2020	JM
4	Updated Nomenclature to Reflect 3-Phase IntelliStart Availability	18 Mar 2013	DS
12	Updated Electrical Data to Reflect 3-Phase IntelliStart Availability	18 Mar 2013	DS
18-24	Updated Controls Section	18 Mar 2013	DS
29	Updated Heat of Extraction/Rejection Data	18 Mar 2013	DS
35	Added Revision Guide	18 Mar 2013	DS



Manufactured by  
WaterFurnace International, Inc.  
9000 Conservation Way  
Fort Wayne, IN 46809  
[www.waterfurnace.com](http://www.waterfurnace.com)



IM1007WNA 01/23

Product:	<b>Envision NDW</b>
Type:	Hydronic Heat Pump
Size:	8-15 Tons
Document:	Installation Manual