



# ENVISION<sup>2</sup>

Envision<sup>2</sup> Compact 0.75 to 6 Ton  
Water Source/Geothermal Heat Pump



# AHRI/ISO 13256-1 PERFORMANCE RATINGS

## PSC Motor

AHRI/ASHRAE/ISO 13256-1

English (IP) Units

Model	Capacity Modulation	Flow Rate		Water Loop Heat Pump				Ground Water Heat Pump				Ground Loop Heat Pump			
				Cooling EWT 86°F		Heating EWT 68°F		Cooling EWT 59°F		Heating EWT 50°F		Cooling Full Load 77°F Part Load 68°F		Heating Full Load 32°F Part Load 41°F	
		gpm	cfm	Capacity Btuh	EER Btuh/W	Capacity Btuh	COP	Capacity Btuh	EER Btuh/W	Capacity Btuh	COP	Capacity Btuh	EER Btuh/W	Capacity Btuh	COP
009	Single	3.0	350	9,600	14.5	13,200	5.2	10,800	22.2	10,600	4.4	9,800	16.7	7,800	3.4
012	Single	3.5	400	12,300	15.7	14,800	5.1	14,500	25.5	12,300	4.5	13,000	18.0	9,600	3.7
015	Single	4.0	500	14,400	15.9	18,500	5.1	16,700	26.0	15,500	4.5	15,000	18.0	12,000	3.8
018	Single	5.0	600	18,000	15.6	23,000	5.1	21,000	25.5	19,000	4.4	18,500	18.0	14,700	3.8
024	Single	8.0	850	24,800	16.2	29,600	5.0	28,100	24.0	23,900	4.3	26,000	19.2	18,900	3.7
030	Single	8.0	900	27,600	18.2	30,600	5.4	30,800	27.1	24,400	4.7	29,200	21.1	19,800	3.8
036	Single	9.0	1200	34,100	17.6	34,200	5.6	36,300	25.7	28,200	4.7	34,600	19.6	24,100	4.0
042	Single	11.0	1300	40,100	16.6	42,800	5.1	44,600	24.5	34,900	4.3	41,600	18.6	27,500	3.7
048	Single	12.0	1500	46,400	15.5	53,100	4.9	51,600	22.5	43,400	4.2	48,900	17.3	35,000	3.6
060	Single	15.0	1800	61,300	15.4	69,000	5.0	68,700	23.2	55,100	4.4	65,500	18.2	43,200	3.7
070	Single	18.0	2000	67,000	14.5	81,800	4.6	75,900	21.6	66,100	4.0	70,600	17.0	52,000	3.4

Cooling capacities based upon 80.6°F DB, 66.2°F WB entering air temperature  
Heating capacities based upon 68°F DB, 59°F WB entering air temperature

3/16/12

## ECM and 5-Speed ECM Motor

AHRI/ASHRAE/ISO 13256-1

English (IP) Units

Model	Capacity Modulation	Flow Rate		Water Loop Heat Pump				Ground Water Heat Pump				Ground Loop Heat Pump			
				Cooling EWT 86°F		Heating EWT 68°F		Cooling EWT 59°F		Heating EWT 50°F		Cooling Full Load 77°F Part Load 68°F		Heating Full Load 32°F Part Load 41°F	
		gpm	cfm	Capacity Btuh	EER Btuh/W	Capacity Btuh	COP	Capacity Btuh	EER Btuh/W	Capacity Btuh	COP	Capacity Btuh	EER Btuh/W	Capacity Btuh	COP
015	Single	4.0	500	14,400	16.5	18,500	5.3	16,700	27.0	15,500	4.7	15,000	18.8	12,000	4.0
018	Single	5.0	600	18,000	16.5	23,000	5.3	21,000	26.8	19,000	4.7	18,500	19.0	14,700	4.1
024	Single	8.0	800	24,800	17.0	29,600	5.3	28,100	27.5	23,900	4.6	26,000	19.6	18,900	3.8
030	Single	8.0	900	27,800	19.2	30,600	5.7	31,200	29.5	24,400	4.8	29,400	21.9	20,000	4.0
036	Single	9.0	1200	34,900	21.6	34,200	6.0	38,000	30.1	28,200	5.1	35,400	22.4	24,100	4.4
042	Single	11.0	1300	40,800	20.0	42,800	5.7	46,200	29.5	35,000	4.9	42,000	21.8	27,500	4.2
048	Single	12.0	1500	47,300	18.5	53,100	5.4	53,000	26.1	43,400	4.7	49,300	20.1	35,000	3.9
060	Single	15.0	1800	61,300	16.6	69,000	5.3	69,000	24.7	57,000	4.7	65,500	19.2	45,000	4.0
070	Single	18.0	2000	67,000	15.4	81,800	5.0	77,400	23.8	67,000	4.4	70,600	18.0	52,500	3.7
026	Full	8.0	950	26,000	17.3	30,300	5.5	29,000	24.0	25,100	5.0	27,700	20.4	19,500	4.3
	Part	7.0	750	20,000	19.5	22,300	6.4	22,600	32.7	18,300	5.3	22,000	27.9	16,300	4.8
038	Full	9.0	1300	39,000	18.0	40,300	5.4	39,400	24.1	33,600	4.8	40,200	21.0	26,700	4.1
	Part	8.0	1150	28,500	20.3	29,100	6.3	31,500	35.4	24,000	5.1	30,100	30.0	22,000	4.8
049	Full	12.0	1600	50,300	17.1	56,100	5.2	56,200	24.5	46,300	4.6	52,000	20.0	37,400	4.0
	Part	11.0	1400	37,200	19.2	39,800	5.8	41,500	33.0	32,300	4.7	40,600	28.5	30,000	4.6
064	Full	16.0	1800	62,000	16.3	70,600	5.2	70,100	23.9	58,000	4.7	65,100	18.7	47,100	4.0
	Part	14.0	1500	45,000	18.0	50,100	5.8	51,500	29.9	41,300	5.0	50,000	25.9	37,000	4.4
072	Full	18.0	2000	69,000	15.0	81,900	4.8	78,500	22.0	67,500	4.3	71,600	17.0	54,200	3.7
	Part	16.0	1500	52,800	16.0	61,400	5.2	61,000	27.0	49,400	4.4	59,000	23.4	45,000	4.1

Cooling capacities based upon 80.6°F DB, 66.2°F WB entering air temperature  
Heating capacities based upon 68°F DB, 59°F WB entering air temperature

3/16/12

BR1022AN 02/15



visit us at [waterfurnace.com](http://waterfurnace.com)

## ENVISION<sup>2</sup> COMPACT

Envision<sup>2</sup> Compact products offer the industry-leading efficiencies of full-size units in a much smaller footprint. The compact cabinet makes this heat pump system the perfect solution for commercial retrofit and boiler/tower applications. Available in a wide selection of capacities (009-072), the Envision<sup>2</sup> Compact carries many of our most advanced features—including the Aurora generation of controls. Options include a factory-installed 24V motorized on/off water valve option for VFD pumping with automatic internal water flow control; hot gas bypass and reheat; and high-efficiency PSC, 5-Speed ECM, or variable speed ECM motors to fit your efficiency and comfort needs. Envision<sup>2</sup> Compact units are more than twice as efficient as the ASHRAE 90.1 standard and utilize environmentally friendly R410A refrigerant.

**Industry-leading efficiencies in a small footprint for unmatched flexibility in geothermal and boiler/tower installations.**



### KEY FEATURES

**COMPRESSOR:** Copeland K-5 Scroll™ or LG rotary (single speed) and Copeland Scroll UltraTech™ (dual capacity) in commercial voltages mounted on a double isolation system.

**WATER LINES:** Copper FPT waterline connections, securely mounted flush to cabinet corner post.

**COAXIAL HEAT EXCHANGER:** Oversized and convoluted with copper inner tube (optional cupronickel) and steel outer tube, designed for maximum heat transfer at normal and low water flow rates to minimize pressure drop.

**ALUMINUM AIR COIL:** An aluminum air coil is featured in all Envision<sup>2</sup> Compact units to provide exceptional durability and high efficiencies. Added protection is also available with an optional AlumiSeal™ coating.

**CABINET:** The cabinets utilize a compact form and are constructed of heavy gauge environmentally responsible galvanized steel for maximum corrosion resistance. Units are available with a durable white powder coat finish or unpainted. All interior surfaces are lined with 1/2" thick, foil lined acoustic type fiber insulation, applied in a manner that prevents the introduction of glass fibers into the air stream. Multiple knockouts in various sizes facilitate power and low voltage wiring.

**REFRIGERANT CIRCUIT:** Units utilize R410A refrigerant in sealed circuits. Metering accomplished with a bi-flow thermostatic expansion valve to deliver optimum flow over a wide range of conditions without troublesome check valves. Four-way solenoid activated reversing valve defaults to heating and is "cool brazed" at the factory.

**FILTER RACK/RAIL:** Redesigned filter rack includes a standard 1" filter rail with a MERV 4 filter. Options include a 1" or 2" four-sided filter rack suitable for ducted applications, or a 2" filter rail with MERV 13 filters for non-ducted applications.

**CONTROLS:** Aurora Base Control is standard. Optional Universal Protocol Converter featuring N2, LonWorks, and BACnet compatibility.

**BLOWER MOTOR:** PSC blower motors provide high efficiency while allowing quiet operation and wide range of airflow selections. Optional 5-Speed ECM and variable speed ECM blower motors are available for improved efficiency and comfort.

**FLOW REGULATOR:** Optional factory installed internal water flow regulator.

**WATER VALVE:** Optional factory installed internal 24V on/off 2-way water valve for VFD pumping applications.

**HOT WATER GENERATOR:** Optional factory installed heat exchanger with field mounted external pump.

#### ADDITIONAL OPTIONS:

- Hot Gas Reheat & Bypass (015-072)
- 460V models with X-13 motor option do not require the additional neutral wire
- Sound kits for Quiet Operation
- Factory installed disconnect, Phase Guard and IntelliStart soft start
- Composite or Stainless Steel drain pans with Secondary drain connections
- Extended range coaxial heat exchanger and piping insulation

## ENVISION<sup>2</sup> COMPACT VERTICAL 0.75 to 6 Ton

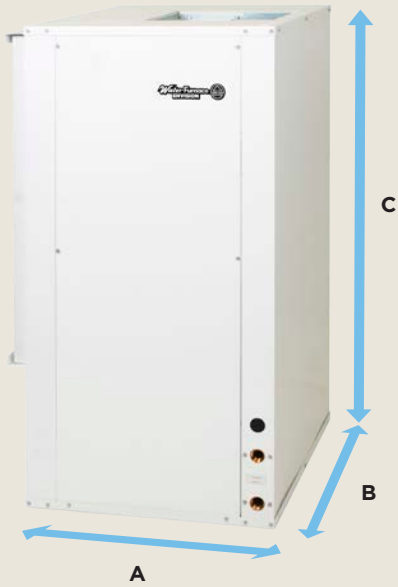

Left Return

Model	A	B	C
009 - 012	22.5	22.2	30.2
015 - 018	22.5	26.2	40.2
024 - 030	22.5	26.2	44.2
036 - 038	25.5	31.2	44.2
042 - 049	25.5	31.2	48.2
060 - 072	25.5	31.2	52.2

More than twice as efficient  
as the ASHRAE 90.1 standard

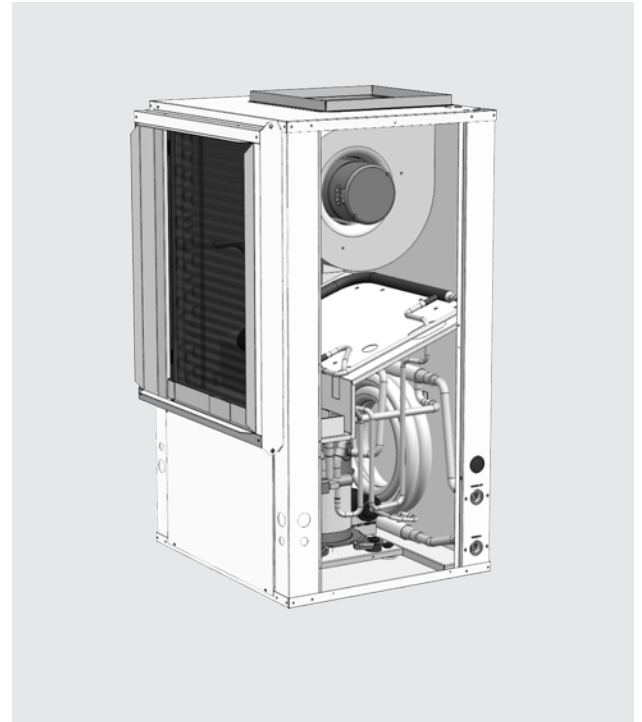

## ENVISION<sup>2</sup> COMPACT HORIZONTAL 0.75 to 6 Ton

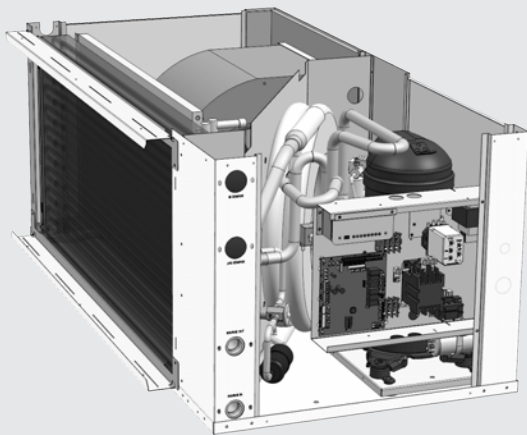

Left Return

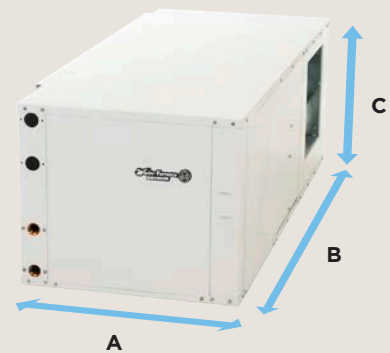

Model	A	B	C
009 - 012	22.5	35.0	17.2
015 - 018	22.5	42.0	19.2
024 - 030	22.5	45.0	19.2
036 - 038	22.5	48.0	21.2
042 - 049	25.5	53.0	21.2
060-064	25.5	61.0	21.2
070-072	25.5	68.0	21.2