

# AURORA

## **Aurora Base Control (ABC) Standard - Version 3.00 Application and Troubleshooting Guide**

For use in all equipment utilizing the Aurora Base Control (ABC) Standard - software version 3.00

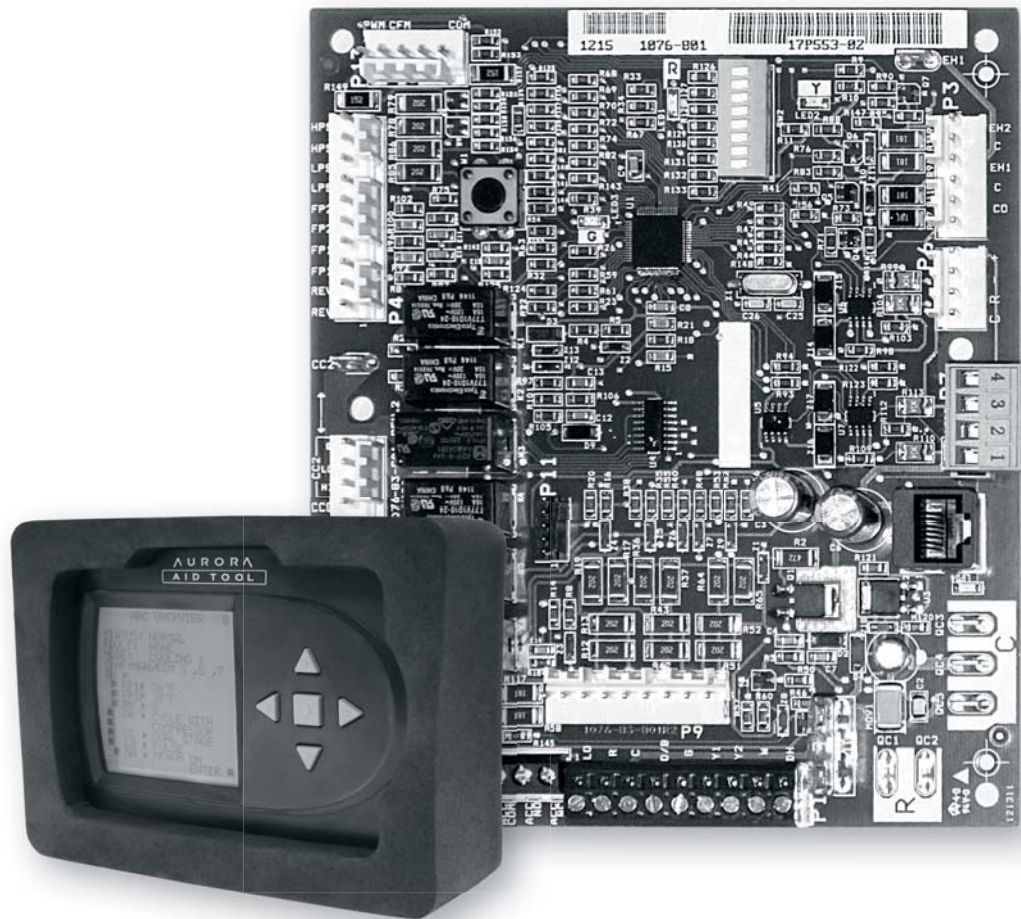

ABC Standard - Version 3.00 Application and Troubleshooting Guide



# Table of Contents

<b>Introduction</b> .....	<b>4</b>
<b>Aurora Interface Diagnostic (AID) Tool</b> .....	<b>4</b>
<b>Control Board Features</b> .....	<b>5</b>
<b>Safety Features</b> .....	<b>5-6</b>
<b>Modes of Operation</b> .....	<b>6-7</b>
<b>Field Selectable Options</b> .....	<b>8-9</b>
<b>Thermistor Data</b> .....	<b>10</b>
<b>Wiring Schematics</b> .....	<b>11-13</b>
<b>Control Board Layout</b> .....	<b>14</b>
<b>Preliminary Checkout Procedure</b> .....	<b>14</b>
<b>Troubleshooting Checklist</b> .....	<b>15</b>
<b>Control Board Troubleshooting Steps</b> .....	<b>16-17</b>
<b>Control Board Troubleshooting Flow Charts</b> .....	<b>18-25</b>
<b>Communicating Thermostat Troubleshooting Guide</b> .....	<b>26-27</b>
<b>Control Board Signals</b> .....	<b>28-30</b>
<b>Jumping the Control Board</b> .....	<b>31-33</b>
<b>Water Side Analysis: Heat of Extraction/Rejection</b> .....	<b>34</b>
<b>Superheat/Subcooling</b> .....	<b>35-36</b>
<b>Revision Guide</b> .....	<b>37</b>

## Introduction

The Aurora Control System is a complete residential and commercial comfort system that brings all aspects of the HVAC system into one cohesive module network. Aurora will use the Modbus communication protocol to communicate between modules. Each module will contain the logic to control all features that are connected to the module. The Aurora Base Control (ABC) has two Modbus channels. The first channel is configured as a master for connecting to devices such as a communicating thermostat, expansion board, or other linked devices. The second channel is configured as a link for connecting the Aurora Interface Diagnostic Tool (AID Tool).

### ABC Part Number

17X553-07

### General Operating Parameters

Operating Environment: -20°F to 158°F and up to 95% relative humidity, non-condensing

Shipping and Storage Environment: -40°F to 185°F and up to 95% relative humidity, non-condensing

Power Requirements: input voltage range of 18 to 30 VAC

Power Consumption: normal 12 VA at 24 VAC, maximum 20 VA at 24 VAC

Agency Approvals: UL

### Relay Contact Ratings

Reversing Valve (K1) 10A at 120VAC/30VDC

Compressor (K2) 10A at 120VAC/30VDC

Compressor Speed (K3) N.O. 10A, N.C. 3A at 125VAC

Blower Motor (K4) 10A at 120VAC/30VDC

Alarm/Reheat (K5) 10A at 120VAC/30VDC

Accessory Output (K6) N.O. 10A, N.C. 3A at 125VAC

### Grounding

The control board has plastic standoffs. The ground connection from "C" is required.

## Aurora Interface Diagnostic (AID) Tool

### Aurora Input-Output Diagnostics

Troubleshooting the Aurora logic board can be accomplished using nothing more than a couple of jumper wires and a volt meter. The process can be simplified with the use of the Aurora Interface Diagnostic Tool (AID Tool). The AID Tool allows the user to see lockout and fault history information, thermostat inputs, sensor inputs, system outputs, timer, etc.

### Aurora ABC Checkout

Before replacing the Aurora ABC control board the proper troubleshooting steps must be taken to ensure that the board is the root cause. On the following pages are several flow charts that will assist in checking the control board. If it is found that the control board is faulty, contact technical services for a replacement part.

### Compressor Will Not Start

- Without AID Tool – Pages 18-19
- With AID Tool – Pages 20-21

### ECM Blower Will Not Start

- Without AID Tool – Pages 22-23
- With AID Tool – Pages 24-25



## Control Features

### Single or Dual Capacity Compressors

Either single or dual capacity compressors can be operated.

### Variable Speed ECM Blower Motor Option

A variable speed ECM blower motor can be driven directly using the onboard PWM output. Three blower speeds are available based upon the G, Y1, and Y2/W input signals to the board. The blower speeds can be changed either by the ECM manual configurations mode method or by using the Aurora AID Tool directly. All three blower speeds can be set to the same speed if desired.

### 5-Speed ECM Blower Motor Option

A 5-speed ECM blower motor will be driven directly using the thermostat connections. Any three of the G, Y1, or Y2/W signals can drive any of the 5 available pre-programmed blower speeds on the motor.

### Other Control Features

- Random start at power up
- Anti-short cycle protection
- High and low pressure cutouts
- Loss of charge
- Water coil freeze detection
- Air coil freeze detection
- Over/under voltage protection
- Condensate overflow sensor
- Load shed
- Dehumidification
- Emergency shutdown
- Hot gas reheat operation
- Diagnostic LED
- Test mode push button switch
- Two auxiliary electric heat outputs
- Alarm output
- Accessory output with N.O. and N.C.
- Modbus communication (primary)
- Modbus communication (secondary)

## Safety Features

The following safety features are provided to protect the compressor, heat exchangers, wiring, and other components from damage caused by operation outside of design conditions.

**Fuse** – a 3 amp automotive type plug-in fuse provides protection against short circuit or overload conditions.

**Anti-Short Cycle Protection** – 4 minute anti-short cycle protection for the compressor.

**Random Start** – 5 to 80 second random start upon power up.

**Fault Retry** – in the fault condition, the control will stage off the outputs and then “try again” to satisfy the thermostat Y input call. Once the thermostat input calls are satisfied, the control will continue on as if no fault occurred. If 3 consecutive faults occur without satisfying the thermostat Y input call, then the control will go to Lockout mode.

**Lockout** – when locked out, the blower will operate continuously in low speed, and PSC blower motor output will remain on. The Alarm output (ALM) and Lockout output (L) will be turned on. The fault type identification display LED1 (Red) shall flash the fault code. To reset lockout conditions with SW2-8 On, thermostat inputs “Y1”, “Y2”, and “W” must be removed for at least three (3) seconds. To reset lockout conditions with SW2-8 Off, thermostat inputs “Y1”, “Y2”, “W”, and “DH” must be removed for at least three (3) seconds. Lockout may also be reset by turning power off for at least 5 seconds or by enabling the emergency shutdown input for at least 3 seconds.

**Lockout With Emergency Heat** - if the control is locked out in the heating mode, and a Y2 or W input is received, the control will operate in the emergency heat mode while the compressor is locked out. The first emergency heat output will be energized ten (10) seconds after the W input is received, and the blower will shift to high speed. If the control remains locked out, and the W input is present, additional stage of emergency heat will stage on after two (2) minutes. When the W input is removed, all of the emergency heat outputs will turn off, and the ECM blower will shift to low speed and PSC blower motor output will remain on.

**High Pressure** – fault is recognized when the Normally Closed High Pressure Switch, P4-9/10 opens, no matter how momentarily. The High Pressure Switch is electrically in series with the Compressor Contactor and serves as a hard-wired limit switch if an overpressure condition should occur.

**Low Pressure** - fault is recognized when the Normally Closed Low Pressure Switch, P4-7/8 is continuously open for 30 seconds. Closure of the LPS any time during the 30 second recognition time restarts the 30 second continuous open requirement. A continuously open LPS shall not be recognized during the 2 minute startup bypass time.

**Loss of Charge** – fault is recognized when the Normally Closed Low Pressure Switch, P4-7/8 is open prior to the compressor starting.

**Condensate Overflow** - fault is recognized when the impedance between this line and 24 VAC common or chassis ground drops below 100K ohms for 30 seconds continuously.

## Safety Features cont.

**Freeze Detection** - set points shall be either 30°F or 15°F. When the thermistor temperature drops below the selected set point, the control shall begin counting down the 30 seconds delay. If the thermistor value rises above the selected set point, then the count should reset. The resistance value must remain below the selected set point for the entire length of the appropriate delay to be recognized as a fault. This fault will be ignored for the initial 2 minutes of the compressor run time.

**Over/Under Voltage Shutdown** - An over/under voltage condition exists when the control voltage is outside the range of 18 VAC to 30 VAC. If the over/under voltage shutdown lasts for 15 minutes, the lockout and alarm relay will be energized. Over/under voltage shutdown is self-resetting in that if the voltage comes back within range of 18 VAC to 30 VAC for at least 0.5 seconds, then normal operation is restored.

## Modes of Operation

### Power Up

The unit will not operate until all the inputs and safety controls are checked for normal conditions. The unit has a 5 to 80 second random start delay at power up. Then the compressor has a 4 minute anti-short cycle delay after the random start delay.

### Standby

In standby mode, Y1, Y2, W, DH, and G are not active. Input O may be active. The blower and compressor will be off.

### Heating Operation

#### Heating, 1st Stage (Y1)

The blower is started on low speed immediately and the compressor is energized 10 seconds after the Y1 input is received. The ECM blower motor is switched to medium speed 15 seconds after the Y1 input.

#### Heating, 2nd Stage (Y1, Y2)

The compressor will be staged to full capacity 20 seconds after Y2 input is received. The ECM blower will shift to high speed 15 seconds after the Y2 input is received.

#### Heating, 3rd Stage (Y1, Y2, W)

The first stage of electric heat is energized 10 seconds after the W command is received. If the demand continues the second stage of electric heat will be energized after 5 minutes.

#### Emergency Heat (W)

The blower will be started on low speed, 10 seconds later the first stage of electric heat will be turned on. 5 seconds after the first stage of electric heat is energized the blower will shift to high speed. If the emergency heat demand is not satisfied after 2 minutes the second electric heat stage will be energized.

### Blower (G)

The blower will start immediately upon receiving a thermostat G command. If there are no other commands from the thermostat the ECM will run on low speed until the G command is removed. Regardless of blower input (G) from the thermostat, the blower will remain on low speed for 30 seconds at the end of each heating cycle.

### Cooling Operation

In all cooling operations, the reversing valve directly tracks the O input. Thus, anytime the O input is present, the reversing valve will be energized.

#### Cooling, 1st Stage (Y1,O)

The blower is started on low speed immediately and the compressor is energized 10 seconds after the Y1 input is received. The ECM blower motor is switched to medium speed 15 seconds after the Y1 input.

#### Cooling, 2nd Stage (Y1, Y2, O)

The compressor will be staged to full capacity 20 seconds after Y2 input was received. The ECM blower will shift to high speed 15 seconds after the Y2 input was received.

### Blower (G)

The blower will start immediately upon receiving a thermostat G command. If there are no other commands from the thermostat the ECM will run on low speed until the G command is removed. Regardless of blower input (G) from the thermostat, the blower will remain on low speed for 30 seconds at the end of each heating, cooling, emergency heat, and reheat cycle.

### Dehumidification (Y1, O, DH or Y1, Y2, O, DH)

When a DH command is received from the thermostat during a compressor call for cooling the ECM blower speed will be reduced by 15% to increase dehumidification.

## Modes of Operation cont.

Blower Speed Selection Number	PWM %	Dehumidification PWM %
1	2	2
2	11	3
3	19	9
4	31	20
5	41	28
6	52	37
7	60	44
8	68	51
9	78	59
10	89	69
11	95	74
12	98	76

### Emergency Shutdown

Four (4) seconds after a valid ES input, P2-7 is present, all control outputs will be turned off and remain off until the emergency shutdown input is no longer present. The first time that the compressor is started after the control exits the emergency shutdown mode, there will be an anti-short cycle delay followed by a random start delay. Input must be tied to common to activate.

### Continuous Blower Operation

The blower output will be energized any time the control has a G input present, unless the control has an emergency shutdown input present. The blower output will be turned off when G input is removed.

### Load Shed

The LS input disables all outputs with the exception of the blower output. When the LS input has been cleared, the anti-short cycle timer and random start timer will be initiated. Input must be tied to common to activate.

### Hot Gas Reheat Operation

#### Reheat (DH, SW2-8 OFF)

When SW2-8 is set to the "OFF" position the Alarm/Reheat Output will be used to control a hot gas reheat valve. If the control receives a DH command and there is no requirement from the space for heating or cooling (Y1 or Y2 command) the control will operate in second stage cooling mode. 30 seconds after the compressor output (CC) energizes, the Alarm/Reheat output will be energized. The control will run reheat until the requirement has been satisfied or there is a command from the space for heating or cooling (Y1, Y2, or both). If the command from the space is for cooling (Y1, Y2, O) the control will simply de-energize the Alarm/Reheat output and cool the space without disabling the compressor. If there is still a command for dehumidification from the space once cooling is satisfied, the control re-energizes the Alarm/Reheat output without disabling the compressor output. If the command from the space is for heating the control will disable the compressor output and de-energize the Alarm/Reheat output. After the compressor short cycle delay is satisfied the control will re-start the unit in the heating mode. If there is still a command for dehumidification from the space once heating is satisfied the control will once again shut down the compressor for the compressor short cycle delay. Once the compressor short cycle delay has satisfied, the sequence for starting the reheat cycle will be repeated.

# Field Selectable Options

## Field Selectable Options via Hardware

**DIP Switch (SW1)** – Test/Configuration Button (See SW1 Operation Table)

### Test Mode

The control is placed in the test mode by holding the push button switch SW1 for 2 - 5 seconds. In test mode most of the control timings will be shortened by a factor of sixteen (16). LED3 (green) will flash at 1 second on and 1 second off. Additionally, when entering test mode LED1 (red) will flash the last lockout one time. Test mode will automatically time out after 30 minutes.

Test mode can be exited by pressing and holding the SW1 button for 2 to 5 seconds or by cycling the power.

**Test mode will automatically be exited after 30 minutes.**

### ECM Configuration Mode

The control is placed in ECM configuration mode by holding the pushbutton switch SW1 for 5 to 10 seconds, the high, medium, and low ECM speeds can be selected by following the LED display lights. LED2 (yellow) will fast flash when entering ECM configuration. When setting low speed LED3 (green) will be continuously lit, for medium speed LED1 (red) will be continuously lit, and for high speed both LED3 (green) and LED1 (red) will be continuously lit. During ECM configuration mode LED2 (yellow) will flash each of the 12 possible blower speeds 3 times. When the desired speed is flashed press SW1, LED2 will fast flash until SW1 is released. Low speed has now been selected. Next select medium speed, and high speed blower selections following the same process above. After third selection has been made, the control will exit the ECM configuration mode.

### Reset Configuration Mode

The control is placed in reset configuration mode by holding the push button switch SW1 for 50 to 60 seconds. This will reset all configuration settings and the EEPROM back to the factory default settings. LED3 (green) will turn off when entering reset configuration mode. Once LED3 (green) turns off release SW1 and the control will reset.

### DIP Switch (SW2)

- SW2-1** FP1 Selection – Temperature limit setting for freeze detection. On = 30°F; Off = 15°F.
- SW2-2** FP2 Selection – Future Use
- SW2-3** RV – O/B - thermostat type. Heat pump thermostats with “O” output in cooling or “B” output in Heating can be selected. On = O; Off = B.
- SW2-4** Access Relay Operation (P2)
- and 2-5**

Access Relay Operation	SW2-4	SW2-5
Cycle with Blower	ON	ON
Cycle with Compressor	OFF	OFF
Water Valve Slow Opening	ON	OFF
(Future Use)	OFF	ON

**Cycle with Blower** - The accessory relay will cycle with the blower output.

**Cycle with Compressor** - The accessory relay will cycle with the compressor output.

**Water Valve Slow Opening** - The accessory relay will cycle and delay both the blower and compressor output for 90 seconds.

**SW2-6** CC Operation – selection of single or dual capacity compressor. On = Single Stage; Off = Dual Capacity

**SW2-7** Lockout and Alarm Outputs (P2) – selection of a continuous or pulsed output for both the LO and ALM Outputs. On = Continuous; Off = Pulsed

**SW2-8** Reheat Operation – On = Normal; Off = Reheat

### Alarm Jumper Clip Selection

From the factory, ALM is connected to 24 VAC via JW2. By cutting JW2, ALM becomes a dry contact connected to ALG.

### ECM Blower Speeds

The blower speeds can be changed either by using the ECM manual configurations mode method or by using the Aurora AID Tool directly (see Instruction Guide: Aurora Interface and Diagnostic (AID) Tool topic).

## Field Selectable Options via Software

*(Selectable via the Aurora AID Tool)*

### ECM Blower Speeds

A traditional ECM blower motor can be driven directly using the onboard PWM output. Three blower speeds are available, based upon the G (low), Y1 (med), and Y2/W (high) input signals to the board. The blower speeds can be changed either by the ECM manual configurations mode method (see ECM Configuration Mode topic) or by using the Aurora AID Tool directly. All three blower speeds can be set to the same speed if desired.

## Field Selectable Options cont.

### LED Displays

Slow Flash = 1 second on and 1 second off

Fast Flash = 100 ms on and 100 ms off

Flash Code = 100 ms on and 400 ms off with a 2 second pause between packages

### SW1 Operation

Holding SW1	Description of Operation	LED
2 to 5 seconds	Enter Test Mode	Green LED Slow Flash
5 to 10 seconds	Enter ECM Configure Mode	Yellow LED Off
50 to 60 seconds	Reset Configure Mode (factory default)	Yellow LED Off
> 60 seconds	SW1 Operation Cancel	Yellow LED Back to Normal

"SW1 operation cancel," holding SW1 for longer than 60 seconds operation will be cancelled. Yellow LED will go back to normal operation.

### Fault LED (LED1, Red)

Description of Operation	Fault LED, Red
Normal Mode	OFF
Input Fault Lockout	Flash Code 1
High Pressure Lockout	Flash Code 2
Low Pressure Lockout	Flash Code 3
Freeze Detection 2 - (Future Use)	Flash Code 4
Freeze Detection 1 - (Coax)	Flash Code 5
(Reserved)	Flash Code 6
Condensate Overflow	Flash Code 7
Over/Under Voltage Shutdown	Flash Code 8
Freeze Detection Sensor Error (FP1 Sensor is Out of Range)	Flash Code 11

### Status LED (LED3, Green)

Description of Operation	Fault LED, Green
Normal Mode	ON
Control is Non-functional	OFF
Test Mode	Slow Flash
Lockout Active	Fast Flash
Dehumidification Mode	Flash Code 2
(Reserved)	Flash Code 3
(Reserved)	Flash Code 4
Load Shed	Flash Code 5
ESD	Flash Code 6
(Reserved)	Flash Code 7

### Configuration LED (LED2, Yellow)

Description of Operation	Configuration LED, Yellow
No Software Overwritten	Flashing ECM Setting
DIP Switch was Overwritten	Slow Flash
ECM Configuration Mode	Fast Flash

### Normal and Test Mode Timing and Delays

Event	Normal Timing	Test Mode Timing
Random Start Delay	5 to 80 seconds	≈ 1 second
Compressor On Delay	5 seconds	< 1 second
Blower Off Delay	30 seconds	≈ 2 seconds
Compressor Short Cycle Delay (minimum off time)	4 minutes	≈ 15 seconds
Compressor Minimum On Time	120 seconds	≈ 5 seconds
Fault Recognition Delay - High Pressure	< 1 second	< 1 second
Fault Recognition Delay - Freeze Detection	30 seconds	30 seconds
Fault Recognition Delay - Low Pressure	30 seconds	30 seconds
Fault Recognition Delay - Condensate Overflow	30 seconds	30 seconds
Freeze Detection Bypass at Startup	2 minutes	30 seconds
Low Pressure Bypass at Startup	2 minutes	30 seconds
Auxiliary Heat Staging Delay	5 minutes	≈ 20 seconds
Emergency Heat Staging Delay	2 minutes	≈ 7.5 seconds
Thermostat Call Recognition Time	2 seconds	2 seconds
Compressor Minimum Stage Time	15 seconds	2 seconds
Reheat Delay Time	30 seconds	30 seconds

### Fault Retries Before Lockout

Type of Fault	Total Tries Before Lockout
High Pressure	3 Retries
Low Pressure	3 Retries
Freeze Detection 1 - (Coax)	3 Retries
Freeze Detection 2 - (Future Use)	3 Retries
Condensate Overflow	3 Retries
Over/Under Voltage Shutdown	No Lockout
Freeze Detection Sensor Error (Sensor is out of range)	No Retry

# Thermistor Data

Temp °F	Resistance	Temp °F	Resistance	Temp °F	Resistance	Temp °F	Resistance	Temp °F	Resistance
-10	118,050	41	25,390	92	6,998	143	2,343	194	915
-9	114,230	42	24,703	93	6,838	144	2,297	195	899
-8	110,540	43	24,036	94	6,682	145	2,252	196	884
-7	106,990	44	23,390	95	6,530	146	2,208	197	869
-6	103,560	45	22,763	96	6,381	147	2,166	198	855
-5	100,260	46	22,155	97	6,237	148	2,124	199	841
-4	97,070	47	21,566	98	6,097	149	2,083	200	827
-3	93,994	48	20,994	99	5,960	150	2,042	201	812
-2	91,027	49	20,439	100	5,827	151	2,003	202	799
-1	88,182	50	19,900	101	5,697	152	1,965	203	786
0	85,398	51	19,377	102	5,570	153	1,927	204	773
1	82,730	52	18,870	103	5,447	154	1,891	205	761
2	80,154	53	18,377	104	5,327	155	1,855	206	748
3	77,668	54	17,899	105	5,209	156	1,820	207	736
4	75,268	55	17,435	106	5,095	157	1,785	208	724
5	72,950	56	16,985	107	4,983	158	1,752	209	712
6	70,712	57	16,457	108	4,875	159	1,719	210	700
7	68,550	58	16,122	109	4,768	160	1,686	211	689
8	66,462	59	15,710	110	4,665	161	1,655	212	678
9	64,444	60	15,309	111	4,564	162	1,624	213	667
10	62,495	61	14,920	112	4,466	163	1,593	214	656
11	60,611	62	14,542	113	4,370	164	1,564	215	646
12	58,791	63	14,175	114	4,276	165	1,535	216	635
13	57,031	64	13,818	115	4,184	166	1,506	217	625
14	55,330	65	13,472	116	4,095	167	1,479	218	615
15	53,685	66	13,135	117	4,008	168	1,451	219	606
16	52,095	67	12,808	118	3,923	169	1,425	220	596
17	50,557	68	12,490	119	3,840	170	1,399	221	587
18	49,070	69	12,181	120	3,759	171	1,374	222	578
19	47,632	70	11,881	121	3,680	172	1,349	223	569
20	46,240	71	11,589	122	3,603	173	1,325	224	560
21	44,894	72	11,305	123	3,527	174	1,301	225	551
22	43,591	73	11,030	124	3,454	175	1,277	226	542
23	42,330	74	10,781	125	3,382	176	1,255	227	534
24	41,110	75	10,501	126	3,312	177	1,232	228	526
25	39,929	76	10,247	127	3,243	178	1,210	229	518
26	38,785	77	10,000	128	3,177	179	1,189	230	510
27	37,687	78	9,759	129	3,111	180	1,168	231	502
28	36,607	79	9,536	130	3,048	181	1,148	232	491
29	35,569	80	9,298	131	2,986	182	1,128	233	487
30	34,565	81	9,077	132	2,925	183	1,108	234	479
31	33,592	82	8,862	133	2,856	184	1,089	235	472
32	32,650	83	8,653	134	2,808	185	1,070	236	465
33	31,738	84	8,449	135	2,751	186	1,051	237	458
34	30,854	85	8,250	136	2,696	187	1,033	238	451
35	29,998	86	8,057	137	2,642	188	1,015	239	445
36	29,168	87	7,868	138	2,589	189	997	240	438
37	28,364	88	7,685	139	2,538	190	980	241	431
38	27,586	89	7,506	140	2,488	191	963	242	425
39	26,831	90	7,332	141	2,438	192	947	243	419
40	26,099	91	7,163	142	2,390	193	931	244	412

# Typical Wiring Schematics

## Aurora Base Control with ECM Blower Motor

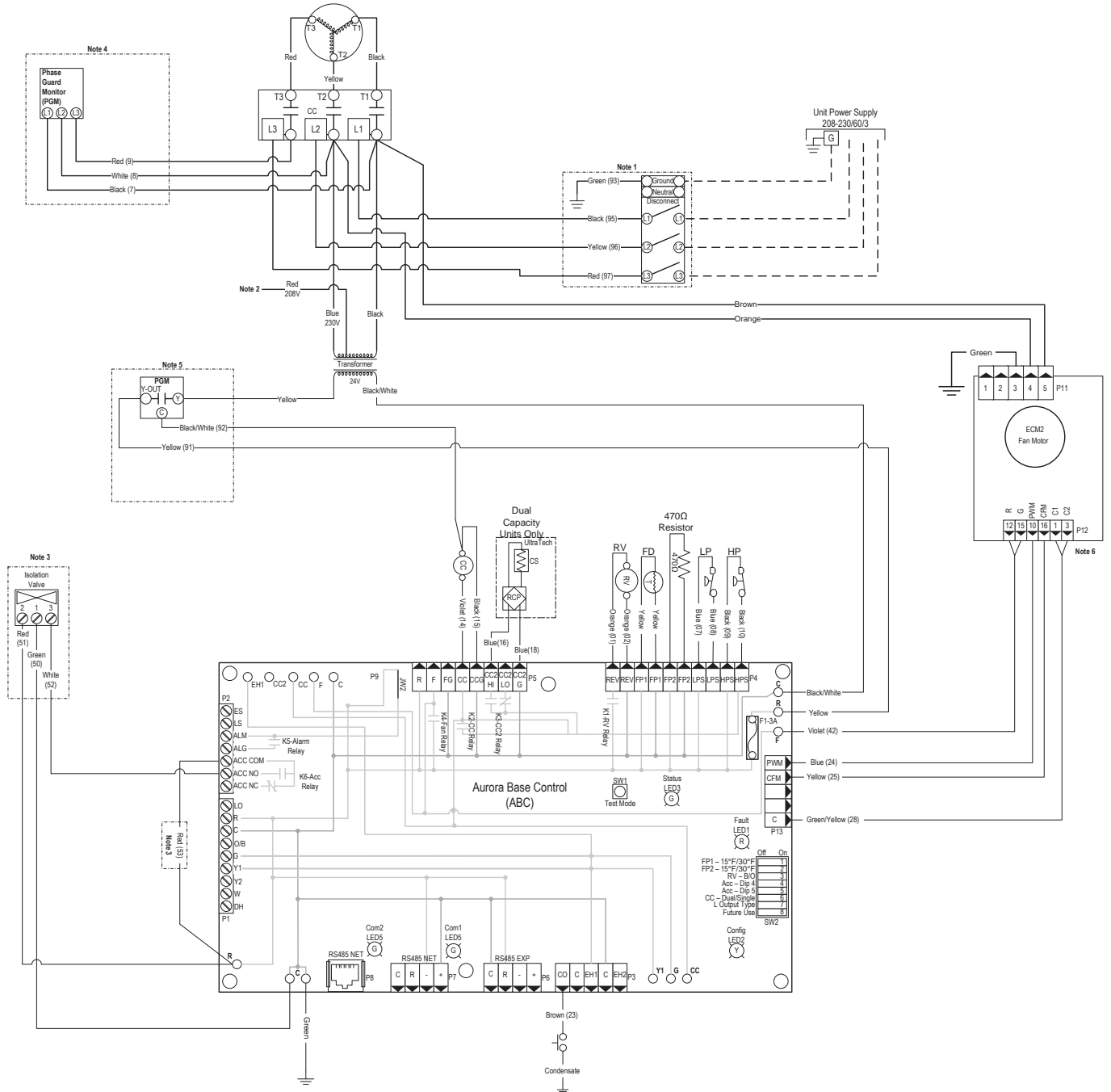

# Typical Wiring Schematics cont.

## Aurora Base Control with PSC Blower Motor

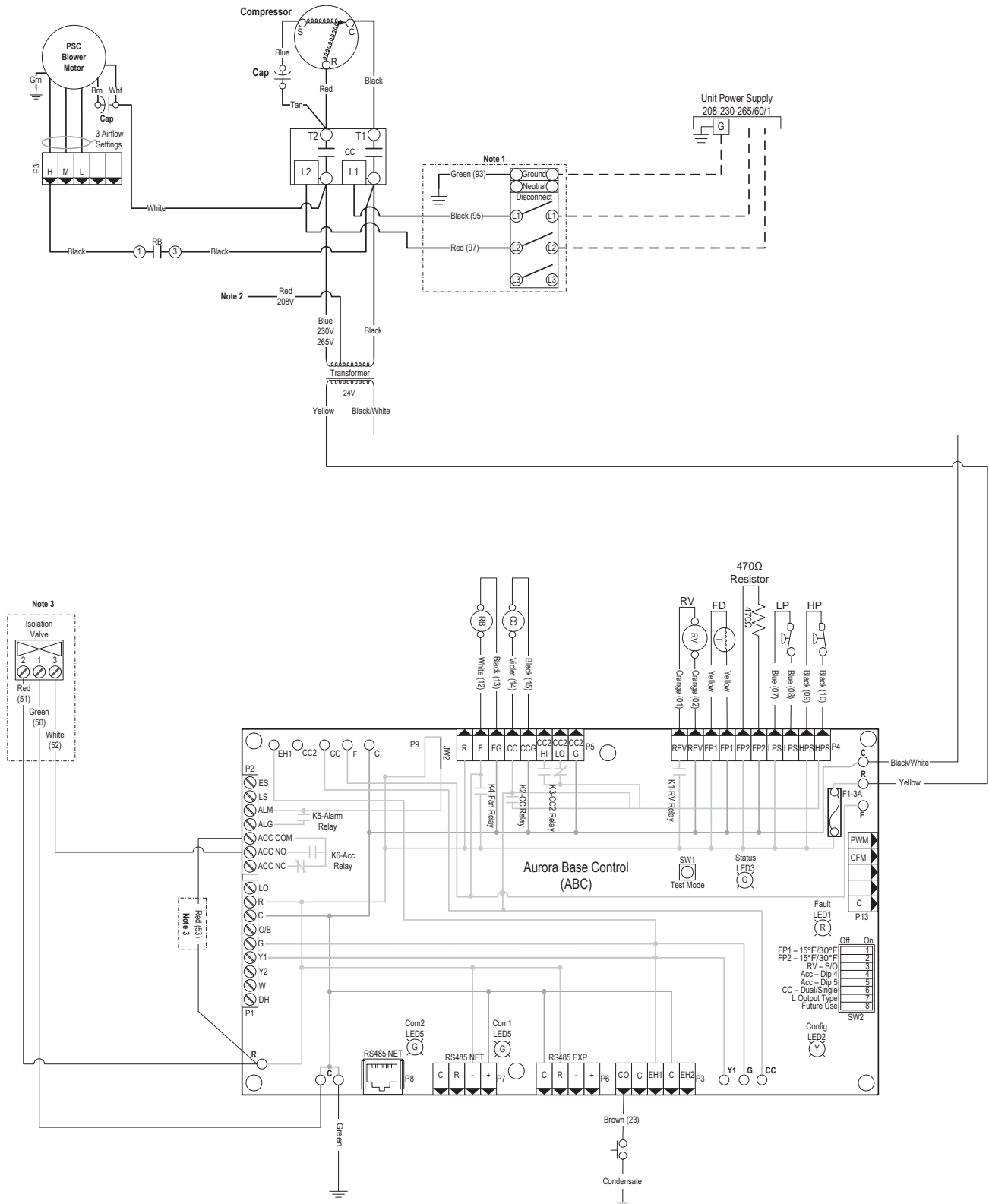

# Typical Wiring Schematics cont.

## Connection for Auxiliary Heater

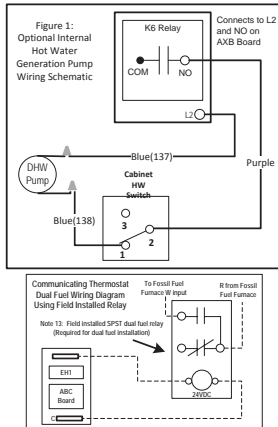
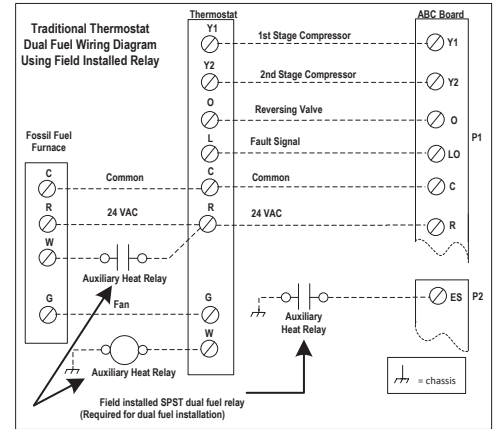
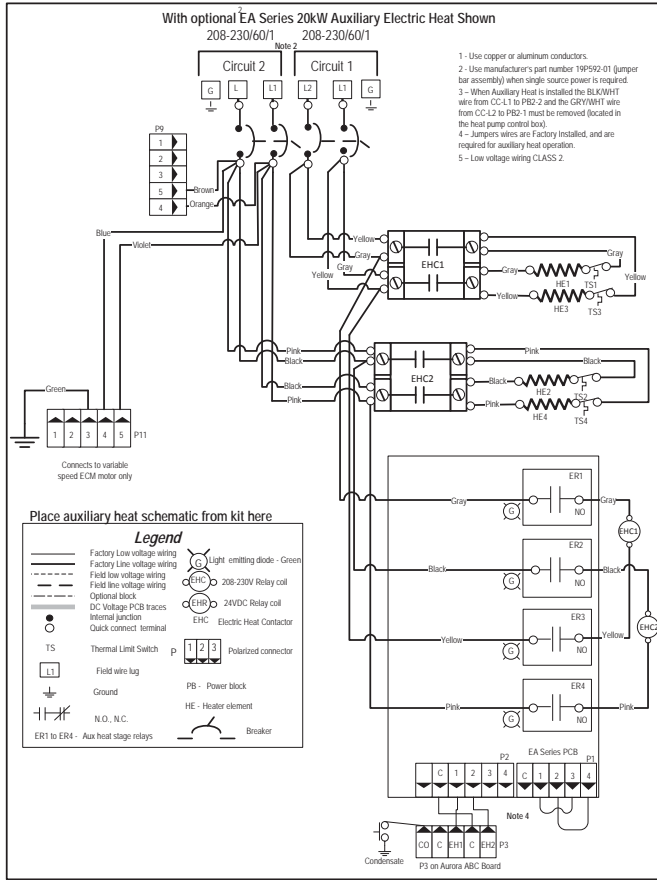

- Notes**
- 1 - Switch blue and red wires for 208V operation.
  - 2 - The blk/wht and gray/wht wires are removed when Aux Heat is installed
  - 3 - Use manufacturer's part number 19P592-01 (jumper bar assembly) when single source power is required.
  - 4 - Variable Speed pump low voltage harness provided with Variable Speed Flow Center.
  - 5 - Low voltage wiring CLASS 2.
  - 6 - Wires provided for Auxiliary Heat low voltage control. Wires are secured at blower.
  - 7 - When Auxiliary Heat is field installed the harness will then be connected to the auxiliary heat unit. The auxiliary heat unit will then power the blower. Refer to EASIEAM/EAL Auxiliary Heat kit installation instructions.
  - 8 - Brown blower power wire routed through Current Transducer two times.
  - 9 - Field Connected: Refer to Installation Manual and Auxiliary Heat Instructions for Current Transducer installation.
  - 10 - Communication cable routed through Ferrite Toroid four times.
  - 11 - Compressor power cable routed through Ferrite Toroid three times.
  - 12 - Variable speed pump power wires to connect the pump to L1 and L2 on the AXB board are provided with Variable Speed Flow Center.
  - 13 - Field installed SPST relay required for dual fuel installation.

# Control Board Layout

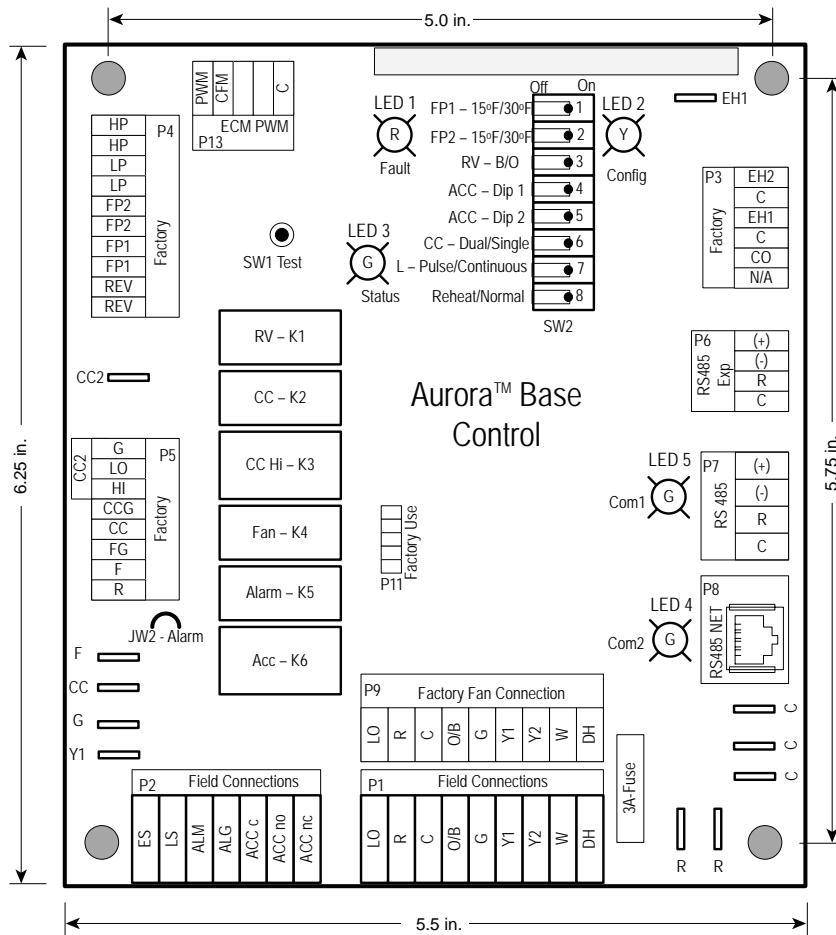

## Preliminary Checkout Procedure

Troubleshooting liquid source heat pumps with Aurora controls is an easy and straight forward process. Most service problems are related to water flow (insufficient or too cold). Also, most service problems can be fixed without connecting refrigerant manifold gauges.

The first item to check is system performance which can be done in six steps. Before beginning make sure the hot water generator pump is disconnected.

**STEP 1:** Check and/or set source water flow. Refer to the install manual for the specific piece of equipment's correct water flow setting.

**STEP 2:** Check the temperature difference through the coaxial heat exchanger and compare to the Operating Parameters table in the equipment install manual.

**STEP 3:** Check the air temperature rise/drop and compare to the Operating Parameters table in the equipment's installation manual.

**STEP 4:** If the first three steps check out, perform a heat of extraction/rejection test as described in the Water Side Analysis: Heat of Extraction/Rejection section to confirm proper operation.

**STEP 5:** If any or all of the above steps do not check out, be sure that the air coil and filter are clean.

**STEP 6:** Check superheat and subcooling by placing refrigeration gauges on the unit. Compare superheat and subcooling values with the charts in the equipment installation manual.

If the above six steps do check out, it would be safe to assume that the unit is performing well and the problem must lie elsewhere, i.e. excessive heat loss/gain in the structure or duct system, (undersized duct and/or registers, etc.)

If you suspect a specific problem, refer to the Table of Contents and select the reference that most closely matches the situation encountered. If problems persist after completing the preliminary checkout procedure, refer to the Troubleshooting Checklist. Select the problem which is closest to the situation you have encountered.

# Troubleshooting Checklist

## Equipment will not start or operate

- Follow the troubleshooting flow charts to find root cause.

## High pressure lockout in the heating mode

- Check for air flow interruption from one or more of the following: inoperative blower, dirty filters or air coil, blocked return air grill, closed or blocked supply registers, restricted supply or return duct, zone dampers, etc. If airflow is suspected as being a problem, make a quick check using the following example: Velocity in a supply duct should not exceed 1000 fpm and 700 fpm in return ducts. For this example we will use a model 038 which has a maximum rating of 1500 cfm at 0.50 static (Refer to the blower performance tables in the install manual for your particular piece of equipment). Using the formula: Area in square feet equals quantity in cfm divided by velocity in fpm ( $A = \text{cfm}/\text{fpm}$ ), 1.57 sq. ft. is needed for the supply duct and 2.14 sq. ft. is needed for the return duct. Refer to the troubleshooting flow charts if a problem with the blower motor or logic board is suspected.
- Check for blocked or seized expansion valve assembly.
- Make sure the discharge pressure is within the operating range shown in the product install manual.
- The unit may be overcharged; check superheat and sub cooling. If this problem is verified, recharge using approved methods.

## High pressure lockout in the cooling mode

- Water flow may be restricted or inadequate. Verify in accordance with the pressure drop tables shown in product install manual. Also, look for the following: solenoid valve may not be opening on well water units, pump(s) may be inoperative in the flow center, debris may be blocking coil (back flush using at least 20 PSI), or air may be in the loop (flush loop).
- Water to refrigerant heat exchanger may be fouled with debris. If so, back flush with at least 20 psi of water pressure.
- If mineral accumulation is evident, clean the heat exchanger with acid.
- Entering air temperature may be too high. Equipment is designed for a maximum of 85°F DB and 71°F WB.
- Check for a seized or blocked expansion valve assembly.
- The unit may be overcharged; check superheat and sub cooling. If this problem is verified, recharge using approved methods.

## Low pressure lockout in heating mode

- If equipment is installed in a low temperature area (below 50°F), install a crankcase heater, then protect the unit from the elements.
- Water flow may be restricted or inadequate. Verify in accordance with the pressure drop tables shown in product install manual. Also, look for the following: solenoid valve may not be opening on well water units, pump(s) may be inoperative in the flow center, debris may be blocking coil (back flush using at least 20 PSI), or air may be in the loop (flush loop).
- Check for a seized or blocked expansion valve assembly.

- Return air temperature may be below 50°F. Block off air coil temporarily to improve flow of refrigerant through the system. Air below 50°F cannot be tolerated on a continuing basis. Correct the problem.
- Refrigerant may be low. Check for leaks, reclaim refrigerant, repair if necessary, recharge using approved methods.

## Low pressure lockout in the cooling mode

- Check for inadequate air flow. Follow the same procedure as shown for a high pressure lockout in the heating mode.
- Check for a seized or blocked expansion valve assembly.
- Refrigerant charge may be low.

## Water flow lockout in either the heating or cooling mode

- Water flow may be restricted or inadequate. Verify in accordance with the pressure drop tables shown in product install manual. Also, look for the following: solenoid valve may not be opening on well water units, pump(s) may be inoperative in the flow center, debris may be blocking coil (back flush using at least 20 PSI), or air may be in the loop (flush loop).
- Disconnect freeze sensor from control and measure the resistance. Cross reference with the Thermistor Data table.

## Condensate over flow lockout in either the heating or cooling mode

- Make sure the drain line pitches away from the unit. Install a vertical vent on horizontal drain lines over six feet long. Clean condensate pan and be sure outlet and drain line from the condensate pan is clear.

## Reversing valve does not operate

- Disconnect solenoid and check for continuity across coil. Replace coil if continuity is not found.
- If stuck reversing valve is suspected, restrict airflow in heating mode (to build pressure), then switch immediately to the cooling mode.

# Control Board Troubleshooting Steps

## 1) General Check

- If any new device was installed, or any wiring was changed, check the connections to ensure the wiring is correct, and all the wires are in good condition.
- Verify all the plugs are securely connected and in good condition.
- Check the DIP switch (SW2) positions are correct.
- Measure 24 VAC between R and C. (The actual reading may be from 18 to 30 VAC). Check the incoming power and the power transformer if the R and C voltage reading is not correct.

## 2) No LEDs are On

- Check 24 VAC on board.
- Check the 3 amp fuse. Replace the fuse if needed.
- Verify transformer circuit breaker has not tripped if no low voltage is present.
- Disconnect the thermostat connection P1.
- Replace the Aurora base control board.

## 3) Red LED Flash Code

**Input Fault (Code 1)** – Indicates that both O and W input signals are present. Disconnect the thermostat connector from the ABC board and then cycle power to the board. If the fault does not reappear, then the problem is between the thermostat and the thermostat connector. Otherwise, replace the ABC board.

**High Pressure Fault (Code 2)** – Indicates the system pressure has exceeded 600 psi (R-410A) which may have been caused by low water flow in cooling, (check coaxial heat exchanger for mineral build-up) or low air flow in heating (check filters and coil for dirt build-up). Measure P4-9 and C is 24 VAC. If not, replace ABC. Check the heat pump refrigeration system. Cycle the power to reset the system. Measure P4-10 and C is 24 VAC. If not, replace the high pressure sensor.

**Low Pressure Fault (Code 3)** – Indicates low pressure switch has opened which may indicate a loss of system charge, system restriction, or frozen heat exchanger. Measure P4-7 and C is 24 VAC. If not, replace ABC. Check the heat pump refrigeration system. Cycle the power to reset the system. Measure P4-8 and C is 24 VAC. If not, replace the low pressure sensor. Refrigerant may be low. Check for leaks, reclaim refrigerant, repair if necessary, pump down and recharge the system to the quantity of refrigerant shown on the unit nameplate.

**Freeze Detection 1 Fault (Code 5)** – Indicates low or no water flow; low system charge; or faulty TXV in heating mode. Make sure the DIP switch FP1 (SW2-1) selection matches the application. Measure the temperature on the refrigerant line next to the freeze detection thermistor. Disconnect the connector P4. Measure the resistance reading between P4-3, P4-4. Refer to the Thermistor Data table, find the corresponding temperature data. Compare the data with the temperature measurement from the refrigerant line. The temperature should be within +/- 2° F. If not, replace the thermistor.

Other items to check when troubleshooting a water flow lockout are superheat, water flow through the coaxial heat exchanger and antifreeze composition. High superheat in heating will lower the refrigerant line temperature where the freeze detection thermistor is located. In this case, check the TXV. Closed loop systems are rated at 3 gpm/ton. If a closed loop system is running at less than 3 gpm/ton, the temperature difference between the refrigerant line and the actual leaving water temperature will be greater and could lead to possible water flow lockouts.

**Condensate Fault (Code 7)** – Indicates condensate water in the drain pan fills up and touches the spade terminal. Make sure the drain line pitches away from the unit. Install a vertical vent on horizontal drain lines over six feet long. Clean and be sure outlet and drain line from the condensate pan is clear. Jumper between R, Y2 and O to start 2nd stage cooling. Observe the water level in the drain pan. If the unit is locking out on condensate and the drain pan is dry, remove the condensate wire from the drain pan and tape it out of the way. Be careful to not ground the wire out because that will cause the unit to lockout on drain overflow. If the unit is still locking out, check the brown wire all the way back to the ABC for a short to ground. Remember that the condensate sensor is just a wire looking for a ground. If it touches any metal in the cabinet, the unit will see that as a drain fault. If removing the wire from the drain pan stopped the false drain lockouts, put the condensate sensor back in place in the drain pan. Pay close attention to how far the spade terminal sits down in the drain pan. If the terminal is pushed all the way down so that it is touching the bottom of the drain pan, this will cause a drain lockout if there is any trace of water. If the spade terminal fits loosely in the drain pan, spread the terminal open to make it fit snugly in the drain pan.

**Over/Under Voltage Shutdown Fault (Code 8)** – Indicates the control voltage is or had been outside the range of 18 to 30 VAC for more than 15 minutes. Using a voltage meter, check the incoming power line voltage is within + or – 25%. If not, there is a power line issue. Check the secondary of the control transformer with a voltage meter. The voltage should be 18 to 30 VAC. If not, replace the control transformer.

**Freeze Detection FP1 Sensor Fault (Code 11)** – Indicates the freeze detection sensor is out of range. Disconnect the connector P4. Measure the resistance reading between P4-3, P4-4. Refer to the Thermistor Data table, find the corresponding temperature data. Compare the data with the temperature measurement from the refrigerant line. The temperature should be within +/- 2°F. If not, replace the thermistor.

# Control Board Troubleshooting Steps cont.

## 4) Other Faults

### **ECM Motor Will Not Start**

1. Measure the voltage output between P13-1 and P13-5. Reference the chart below for blower speed vs. voltage.

Blower Speed Selection Number	DC Volts
1	0.6 VDC
2	2.7 VDC
3	4.6 VDC
4	7.5 VDC
5	9.8 VDC
6	12.5 VDC
7	14.4 VDC
8	16.3 VDC
9	18.5 VDC
10	21.2 VDC
11	22.3 VDC
12	23.4 VDC

2. Measure the voltage from C to F terminals (P5-2). The reading should be 24VAC.

**Compressor First Stage Will Not Start** – Measure the voltage output between P5-4 and P5-5, P5-7 and P5-8. The reading should be 24 VAC. If 24 VAC is not present check transformer output, thermostat wiring, current fault status, etc.

**Compressor Second Stage Will Not Start** – Measure the voltage output between P5-6 and P5-8. The reading should be 24 VAC. If 24 VAC is not present, check DIP switch settings, thermostat operation, and thermostat wiring.

**PSC Motor Will Not Start** – Measure the voltage output between P5-2 and P5-3. The reading should be 24 VAC.

**No Alarm Output** – Measure the voltage output between P2-4 and C. The reading should be 24 VAC or a pulsed 24 VAC dependent on the selection of SW2-7. If SW2-8 is set for reheat, the alarm output will be used to control the hot gas reheat valve and will not show lockout information.

**Accessory Relay Does Not Operate** – Measure the continuity between P2-2 and P2-3. It should read closed when relay is engaged. If this is not correct, check SW2-4 and SW2-5 settings.

**No Lockout Output** – Measure the voltage output between P1-1 and C. The reading should be 24 VDC or a pulsed 24 VDC dependent on the selection of SW2-7. If voltage is not present, make sure the unit is in lockout and not fault retry.

**Auxiliary Heater Does Not Function** – Measure the voltage output between P3-1, P3-2, and P3-3, P3-4. The output should be 24 VDC. If voltage is not present, check thermostat operation and wiring.

## 5) Operation Modes

**Enter First Stage Heating** – Remove P1. Place a jumper between R and Y1.

**Enter Second Stage Heating** – Remove P1. Place a jumper between R, Y1 and Y2. This is for SW2-6 set to “OFF” position.

**Enter Third Stage Heating** – Remove P1. Place a jumper between R, Y1, Y2 and W.

**Enter First Stage Cooling** – Remove P1. Place a jumper between R, O and Y1.

**Enter Second Stage Cooling** – Remove P1. Place a jumper between R, O, Y1 and Y2.

**Enter Emergency Heating** – Remove P1. Place a jumper between R and W.

**Enter Blower Only Mode** – Remove P1. Place a jumper between R and G.

**Enter Reheat Mode** – Remove P1. Place a jumper between R and DH. (SW2-8 must be off)

These notes are for SW2-3 set to “ON” position.

# Control Board Troubleshooting Flow Charts

Use the following flow charts to aid in troubleshooting the control board.

## Compressor Will Not Start Without AID Tool

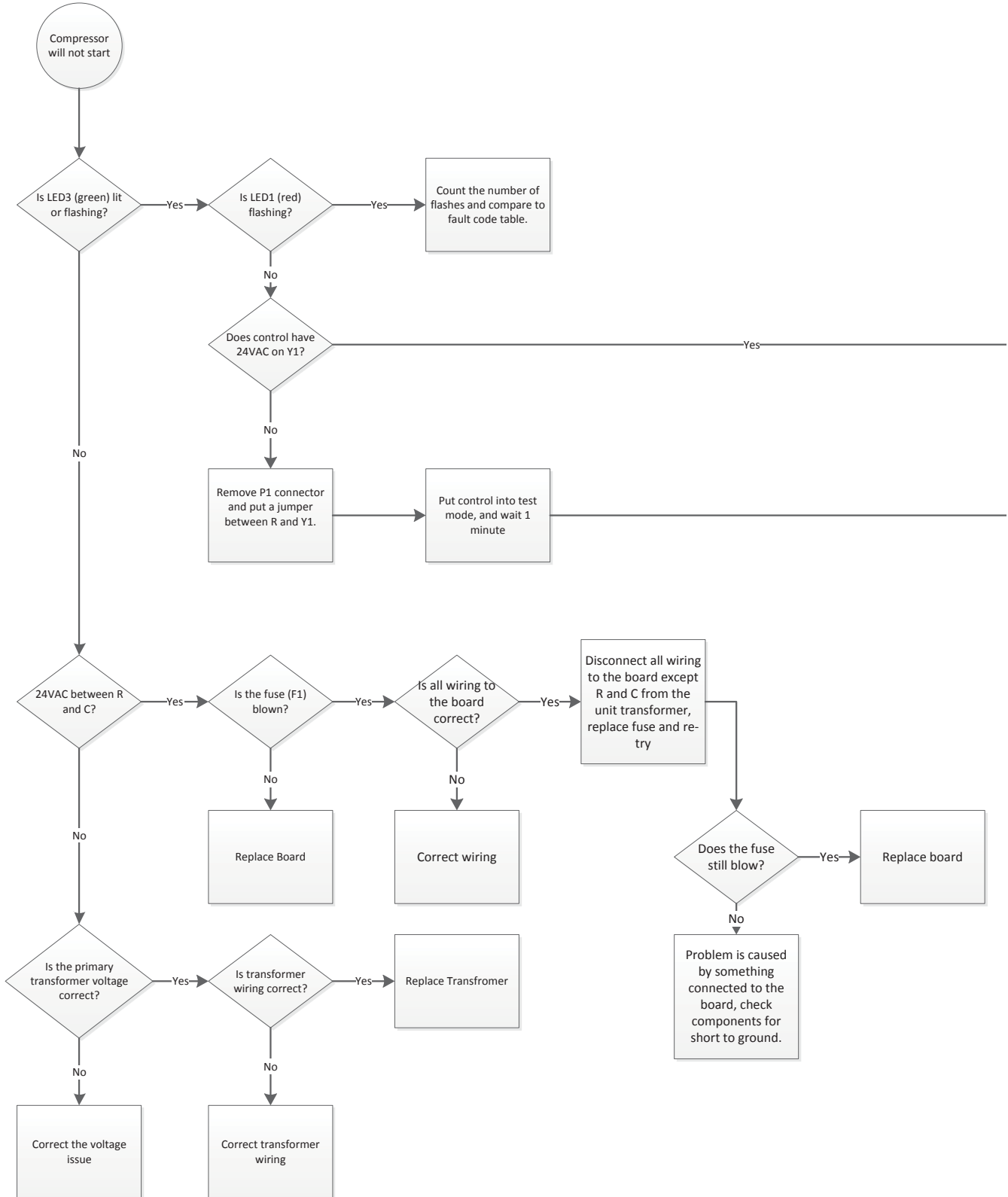

# Control Board Troubleshooting Flow Charts cont.

**Notes:**

1. When measuring 24VAC actual value may be between 18 and 30VAC.

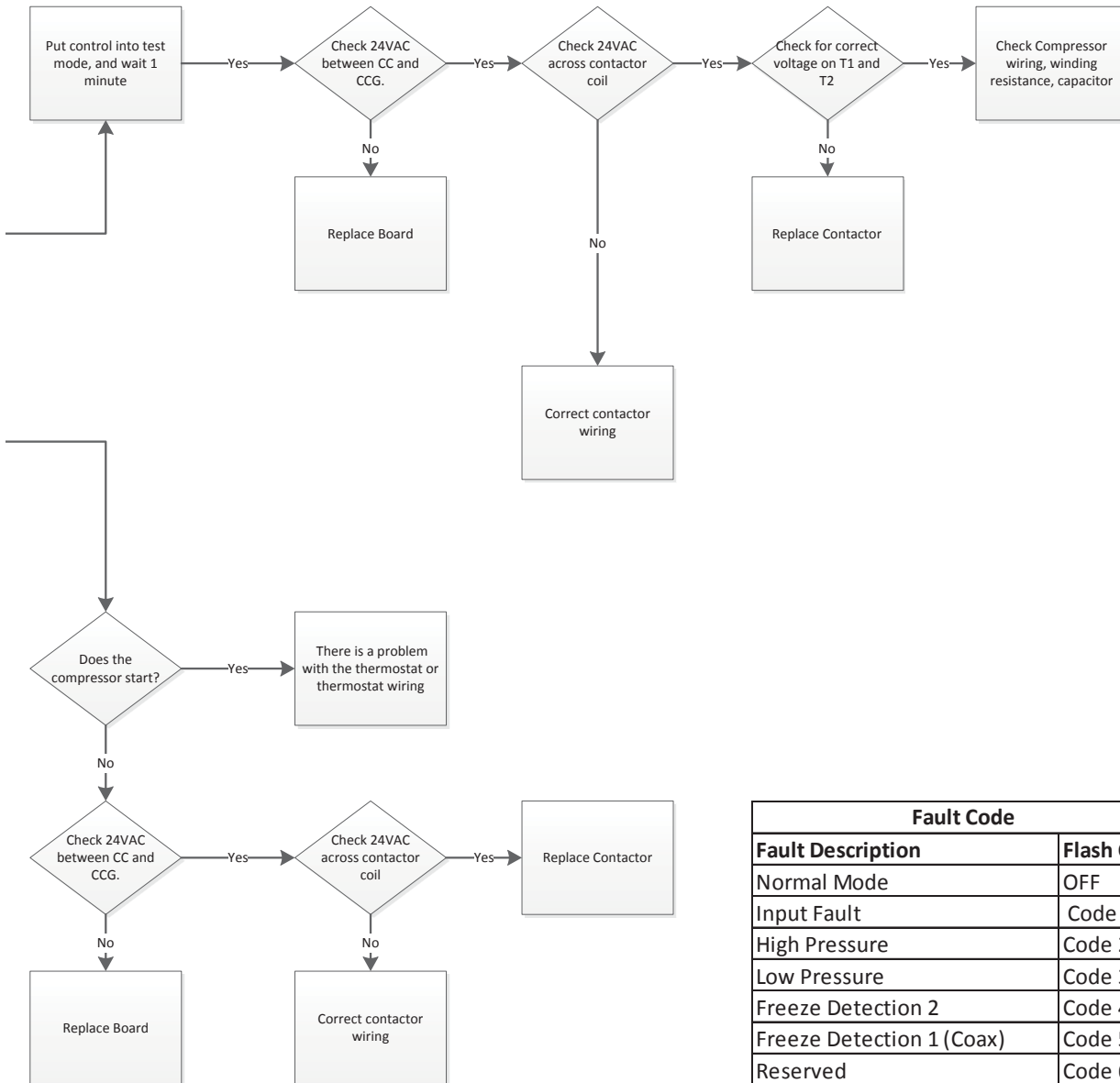

Fault Code	
Fault Description	Flash Code
Normal Mode	OFF
Input Fault	Code 1
High Pressure	Code 2
Low Pressure	Code 3
Freeze Detection 2	Code 4
Freeze Detection 1 (Coax)	Code 5
Reserved	Code 6
Condensate	Code 7
Over/Under Voltage	Code 8
Not Used	Code 9
Freeze Detection Sensor Error	Code 11

**NOTE:** Refer to the Control Board Troubleshooting Steps for fault descriptions.

# Control Board Troubleshooting Flow Charts cont.

## Compressor Will Not Start With AID Tool

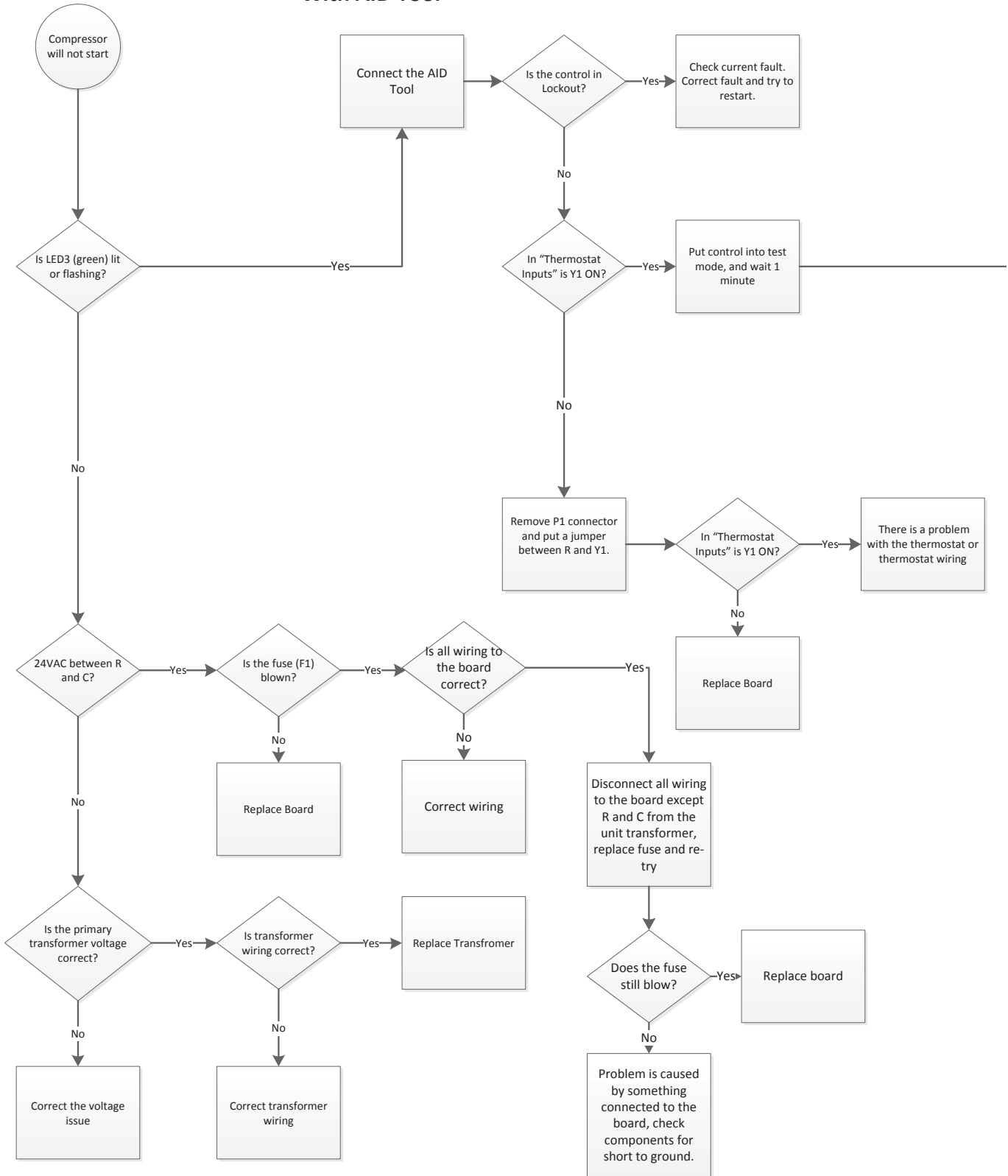

# Control Board Troubleshooting Flow Charts cont.

**Notes:**

1. When measuring 24VAC actual value may be between 18 and 30VAC.

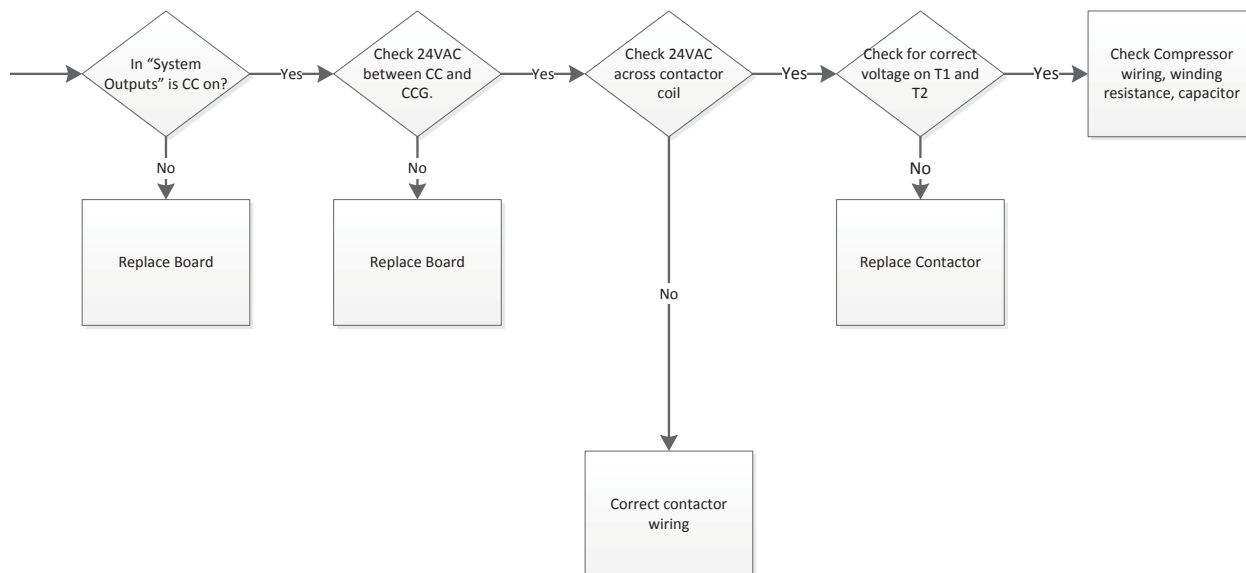

# Control Board Troubleshooting Flow Charts cont.

## ECM Blower Will Not Start Without AID Tool

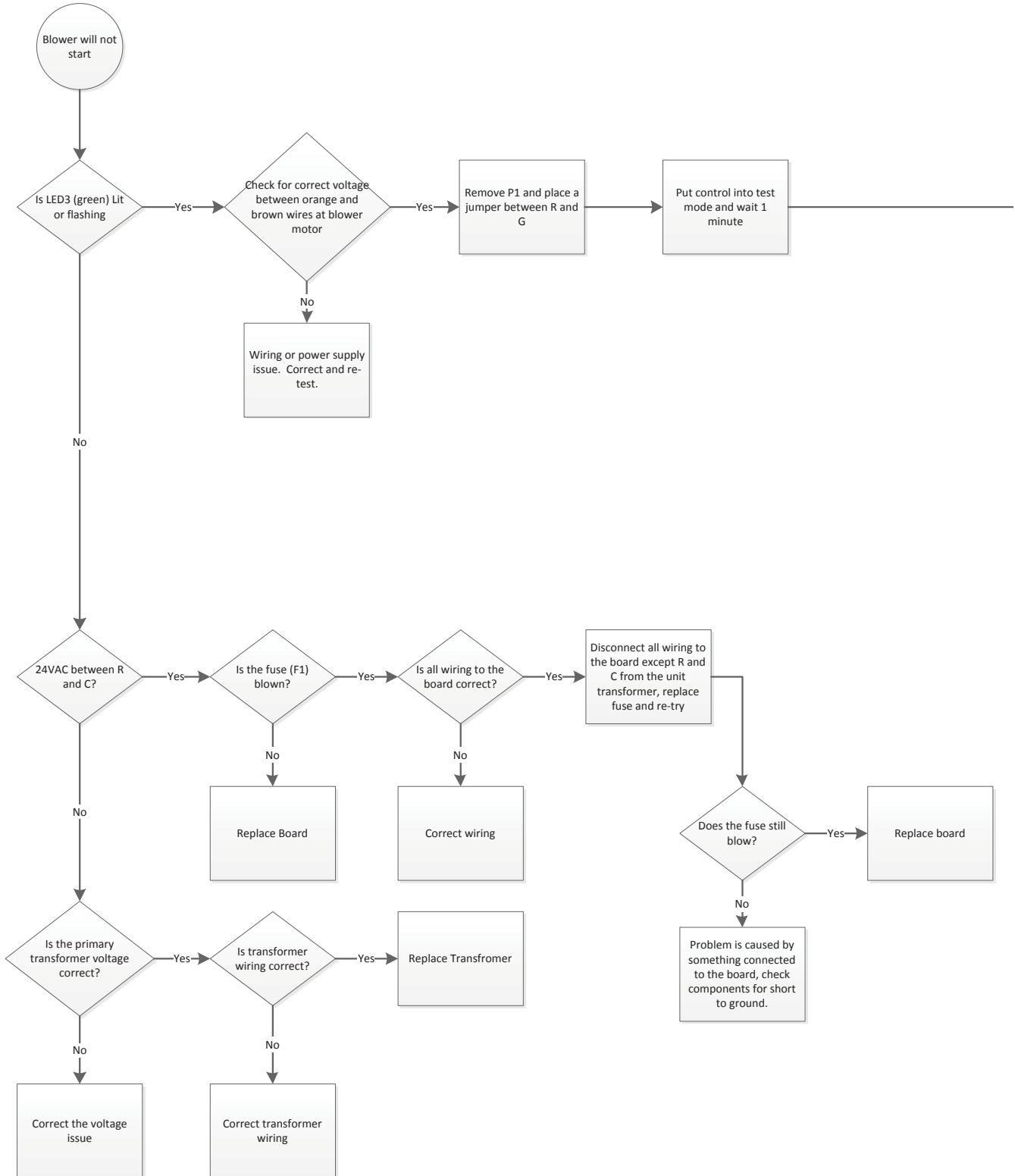

# Control Board Troubleshooting Flow Charts cont.

**Notes:**

1. When measuring 24VAC actual value may be between 18 and 30VAC.

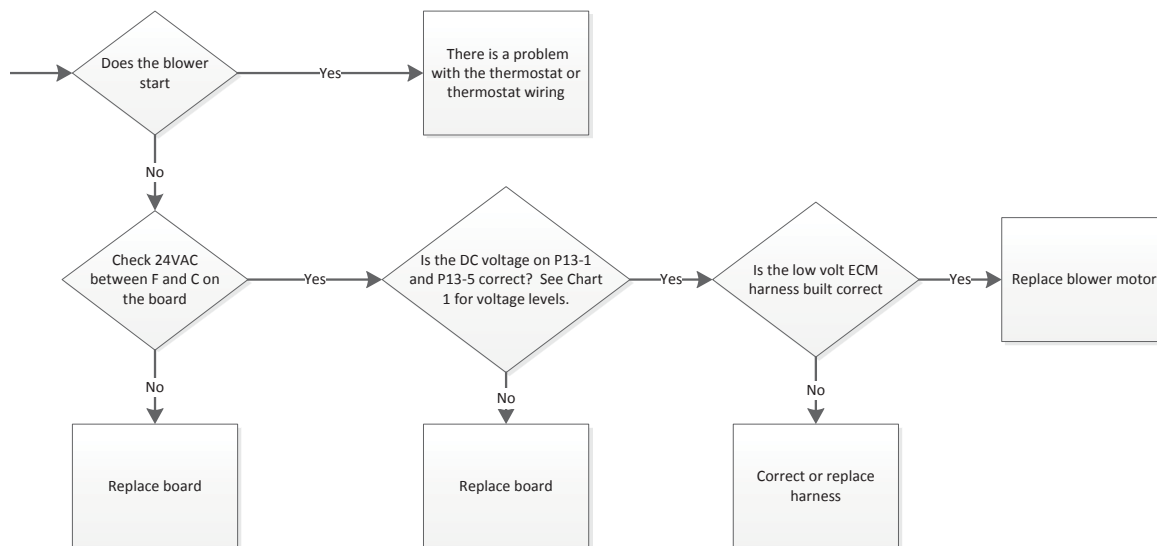
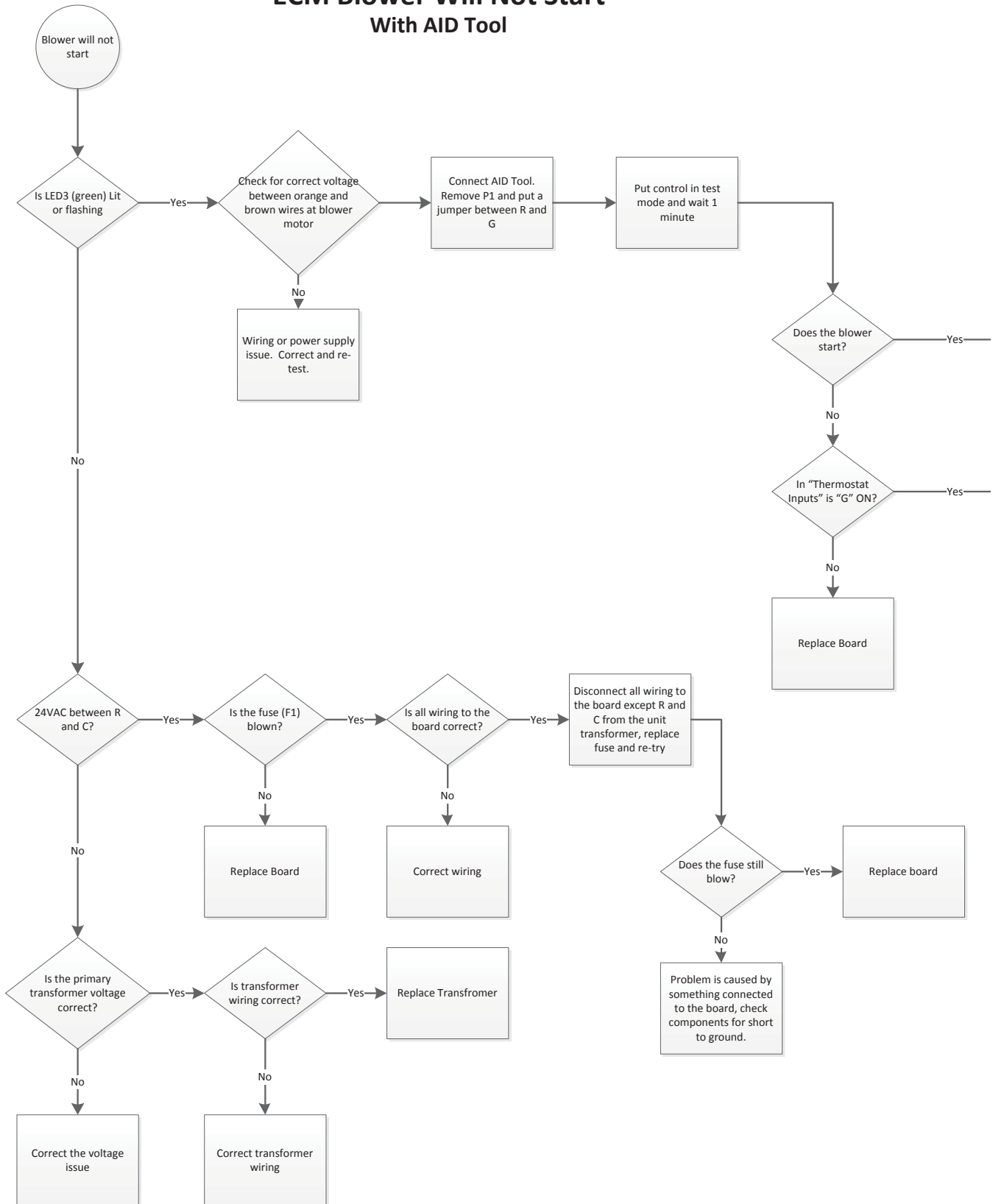

Chart 1

Blower Speed Selection Number	DC Volts
1	0.6VDC
2	2.7VDC
3	4.6VDC
4	7.5VDC
5	9.8VDC
6	12.5VDC
7	14.4VDC
8	16.3VDC
9	18.5VDC
10	21.2VDC
11	22.3VDC
12	23.4VDC

# Control Board Troubleshooting Flow Charts cont.

## ECM Blower Will Not Start With AID Tool



# Control Board Troubleshooting Flow Charts cont.

**Notes:**

1. When measuring 24VAC actual value may be between 18 and 30VAC.

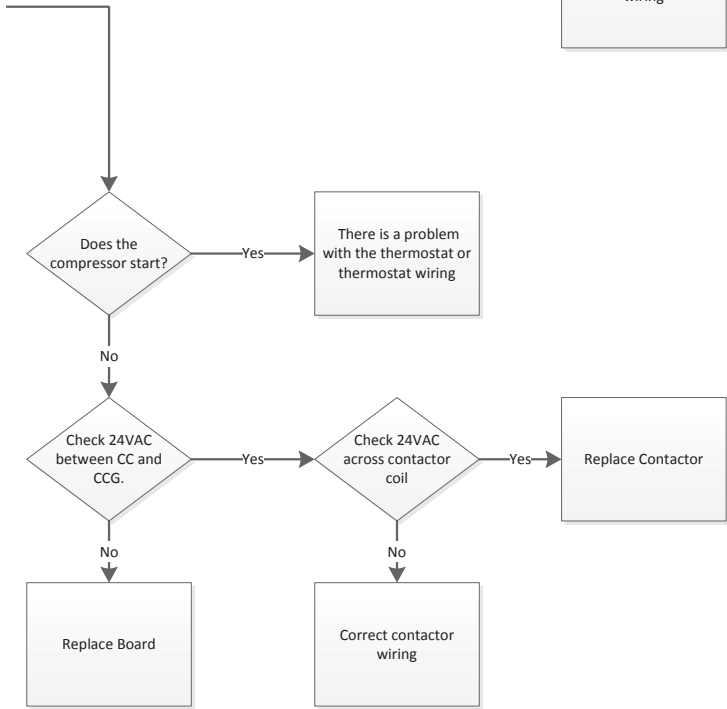
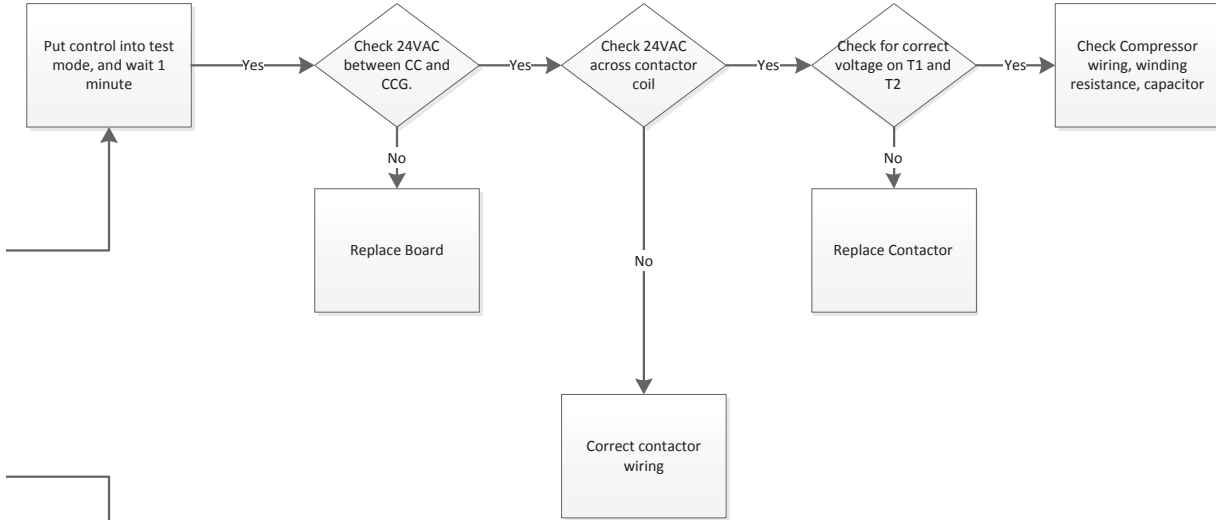

Fault Code	
Fault Description	Flash Code
Normal Mode	OFF
Input Fault	Code 1
High Pressure	Code 2
Low Pressure	Code 3
Freeze Detection 2	Code 4
Freeze Detection 1 (Coax)	Code 5
Reserved	Code 6
Condensate	Code 7
Over/Under Voltage	Code 8
Not Used	Code 9
Freeze Detection Sensor Error	Code 11

# Communicating Thermostat Troubleshooting Guide

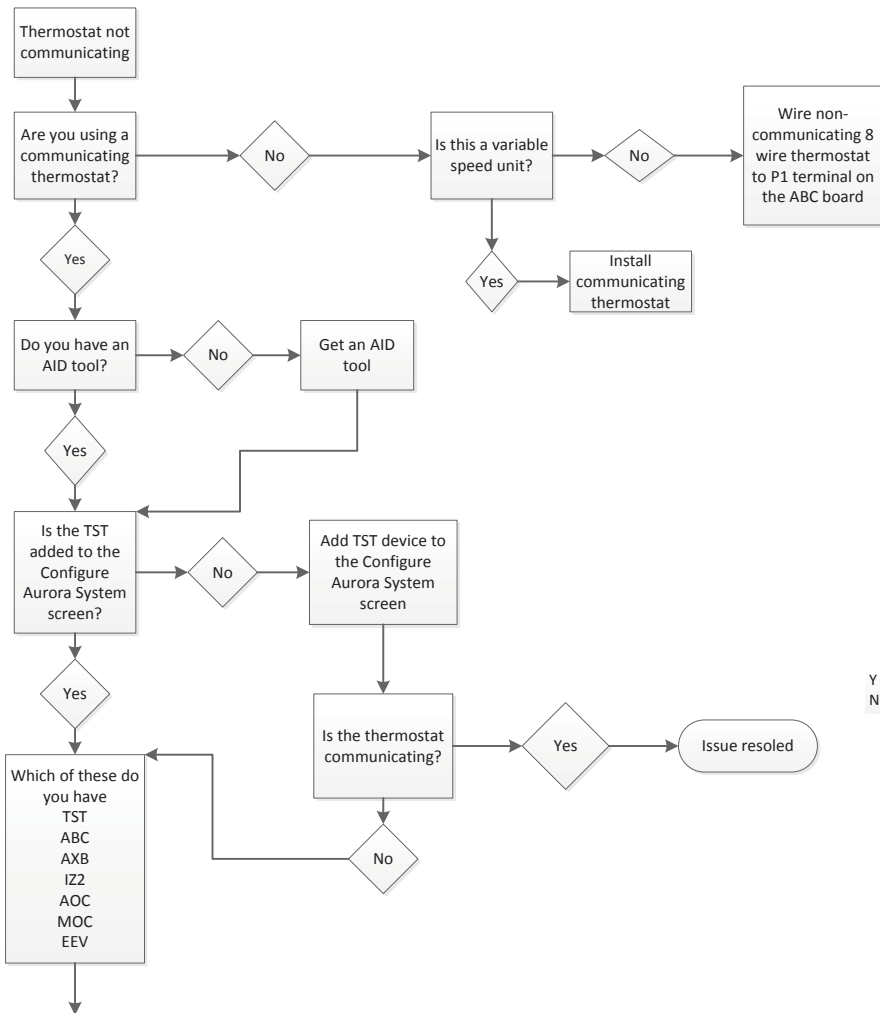

Configure Aurora System Screen

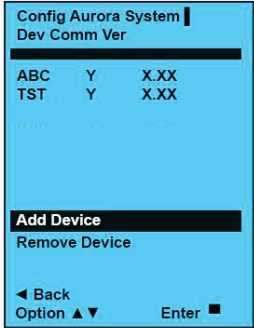

Single and Dual Capacity unit

Y – Active Communication  
 N – Device has been found, but communication has failed.

# Communicating Thermostat Troubleshooting Guide cont.

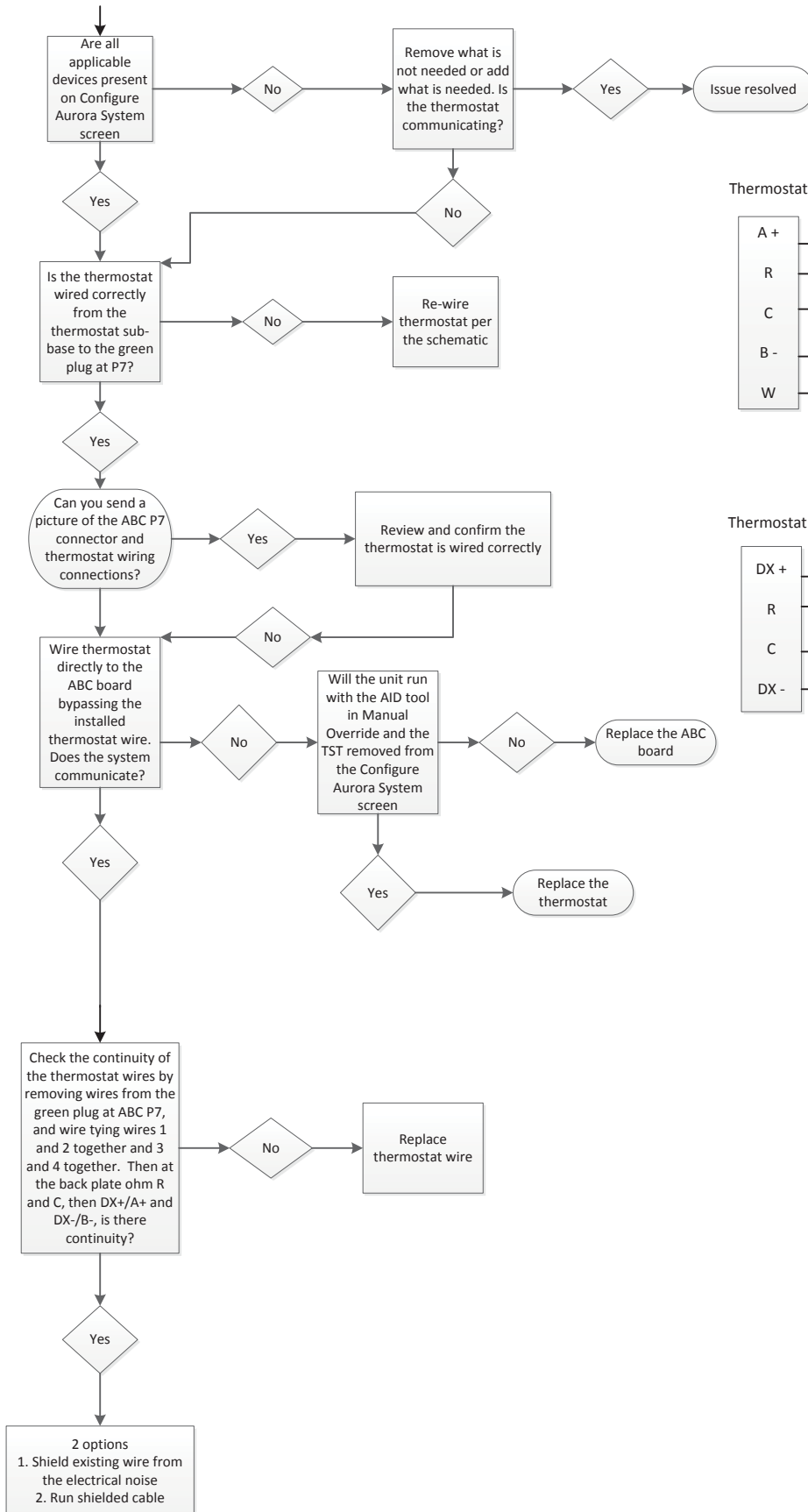

TPCM32U03A\*/TPCM32U04A

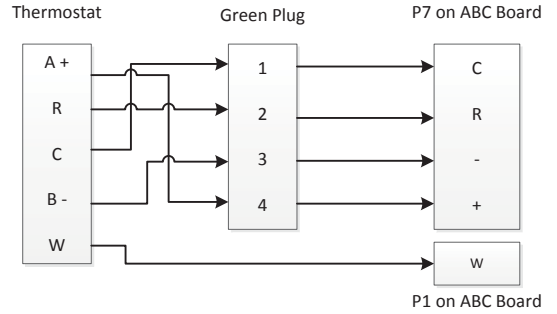

TPCC32U01

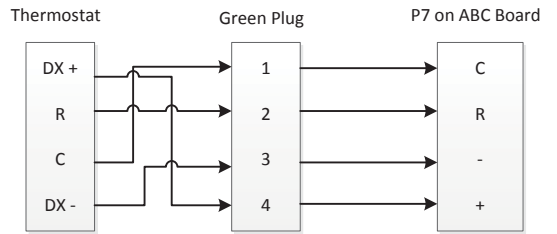

# Control Board Signals

## To Check for 24VAC between R and C

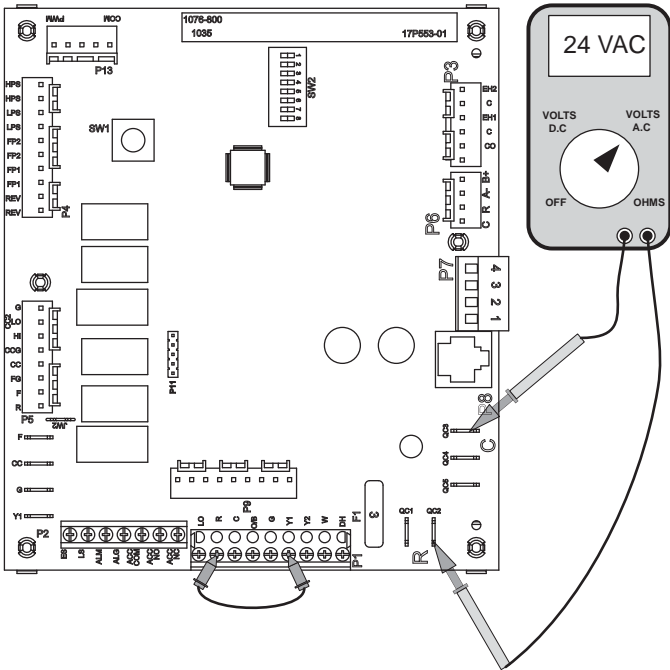

With power applied to the unit connect your Volt meter leads to “R” and “C” on the control board where the yellow and black/white transformer wires connect. The reading should be between 18VAC and 30VAC.

## To Check for 24VAC to Compressor Contactor

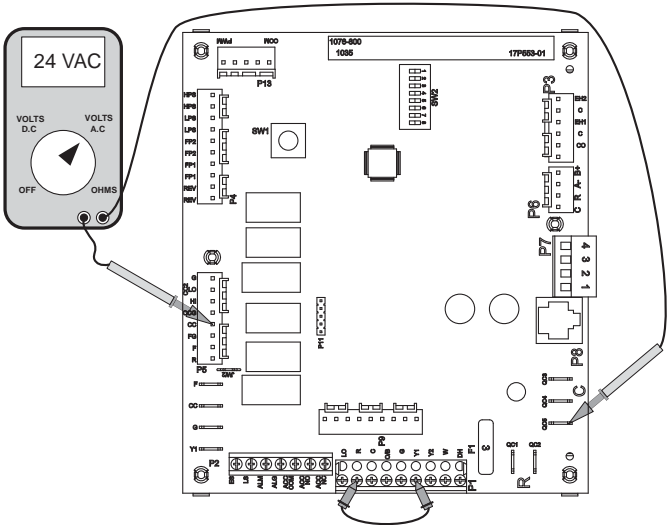

With the AID Tool go to the “Thermostat Inputs” Menu under “Diagnostics” and over-ride the “Y1” input to ON. If an AID Tool is not available remove the P1 connector to disconnect the thermostat from the board and place a jumper wire between “R” and “Y1” as shown. Apply power and put the board into test mode by holding SW1 for 2-5 seconds, the green LED will begin a slow flash. Connect your Volt meter leads to “CC” and “C”. After 1 minute the reading should be between 18 and 30VAC. If you have

a signal and the contactor is not pulled in, check voltage across the contactor coil. If you have voltage across the contractor coil, replace the contactor. If there is no voltage across the contactor coil, verify all wiring between the board and contactor. If you have no voltage between CC and C and the fault LED is not flashing, then replace the board.

## To Check Operation of the Reversing Valve Output

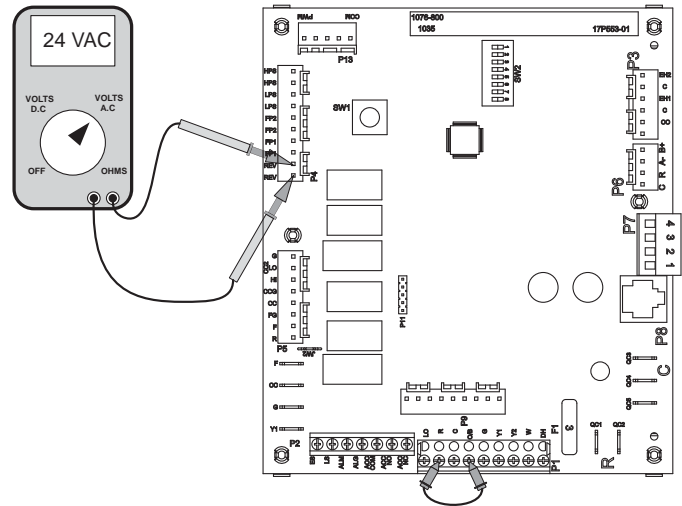

Make sure that SW2-3 is set to “ON”. With the AID Tool go to the “Thermostat Inputs” Menu under “Diagnostics” and over-ride the “O” input to ON. If an AID Tool is not available remove the P1 connector to disconnect the thermostat from the board and place a jumper wire between “R” and “O” as shown. Apply power and put the board into test mode by holding SW1 for 2-5 seconds, the green LED will begin a slow flash. Connect your Volt meter leads to the two “REV” pins on P4. The reading should be between 18 and 30VAC. If you have voltage and the reversing valve is not shifting, check voltage across the coil. If you have voltage across the reversing valve coil, but the valve does not shift the reversing valve coil may be bad. If there is no voltage across the coil, verify all wiring between the board and reversing valve. If no voltage is present on the two REV terminals then replace the board.

# Control Board Signals cont.

## To Check Operation of the Accessory Relay

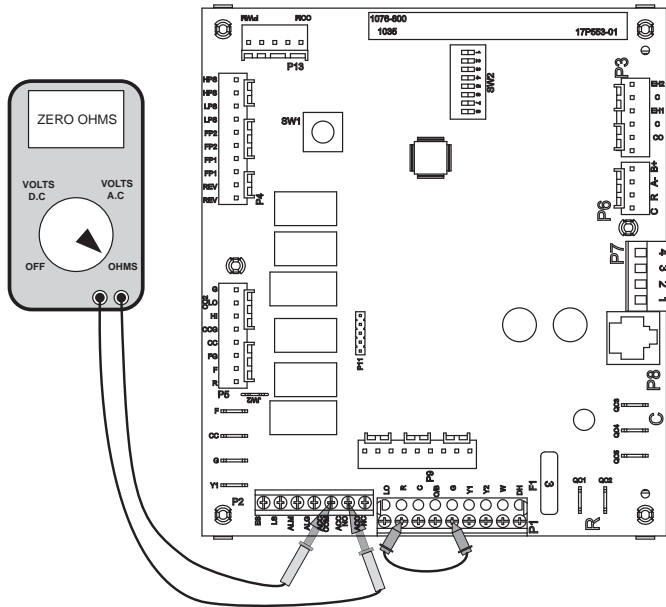

Make sure that SW2-4 and SW2-5 are both set to "ON". With the AID Tool go to the "Thermostat Inputs" Menu under "Diagnostics" and over-ride the "G" input to ON. If an AID Tool is not available remove the P1 connector to disconnect the thermostat from the board and place a jumper wire between "R" and "G" as shown. Apply power and put the board into test mode by holding SW1 for 2-5 seconds, the green LED will begin a slow flash. Connect your Ohm meter leads to the two "ACC COM" and "ACC NO" on P2. A reading of zero ohms indicates that the relay is switching and operating normally. A reading of infinity or open line indicates that the relay did not close and the board should be replaced.

## To Bypass the Safety Circuit and Engage the Compressor Contactor

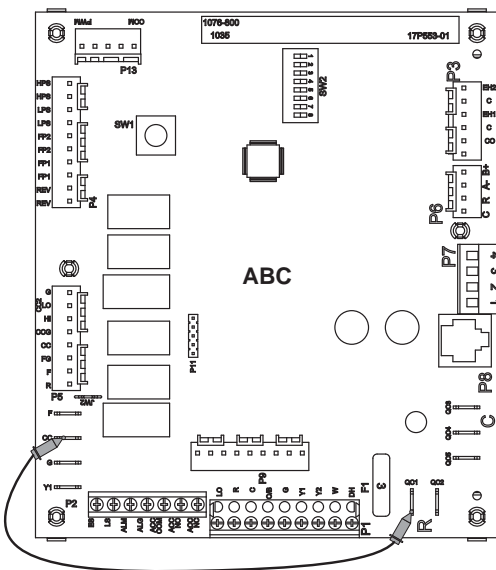

Put gauges on the unit to monitor high/low pressure. Place a jumper between "R" and "CC" as shown. **This will bypass the safety circuit and the compressor will run whether the board is calling for it or not.**

## To Check the Freeze Detection Thermistor (AID Tool Required)

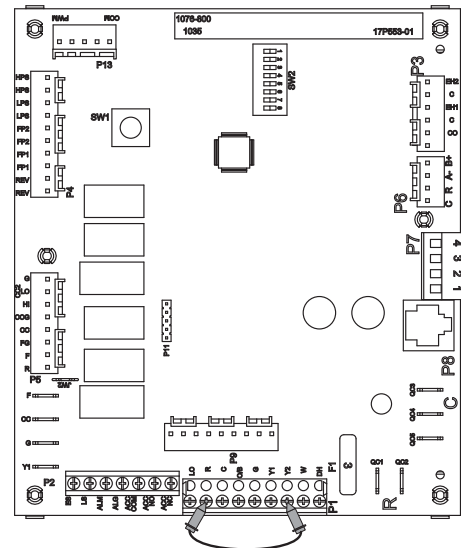

Disconnect the loop pumps so they will not run. Place a thermocouple on the refrigerant line next to the freeze detection thermistor. With the AID Tool go to the "Thermostat Inputs" Menu under "Diagnostics" and over-ride the "Y2" input to ON. If an AID Tool is not available remove the plug on P1 to disconnect the thermostat from the board. Place a jumper on "R" and "Y2" as shown. Apply power and put the board into test mode by holding SW1 for 2-5 seconds, the green LED will begin a slow flash. As the unit runs in second stage heating with the loop pump(s) not working, the lack of water flow will quickly bring down the temperature of the refrigerant line where the freeze detection thermistor is located. Watch the FP1 temperature reading on the AID Tool and compare it with the thermocouple reading. The thermocouple reading and FP1 reading should be within 2 degrees F of each other. If the thermistor is found to be out of calibration, replace the thermistor. Allowing the unit to continue to run will cause a freeze detection fault to occur. Remember, there is a two minute bypass delay and a 30 second recognition delay on the freeze detection input. This means that the compressor will not shut down during the first 2.5 minutes of run time regardless of how low the freeze thermistor reads.

Other items to check when troubleshooting a freeze detection lockout are superheat, water flow through the coaxial heat exchanger, and antifreeze composition. High superheat in heating will lower the refrigerant line temperature where the freeze protection thermistor is located. In this case, check the TXV. Closed loop systems are rated at 3 gpm/ton. If a closed loop system is running at less than 3 gpm/ton, the temperature difference between the refrigerant line and the actual leaving water temperature will be greater and could lead to possible freeze detection lockouts.

# Control Board Signals cont.

## To Check the Condensate Sensor

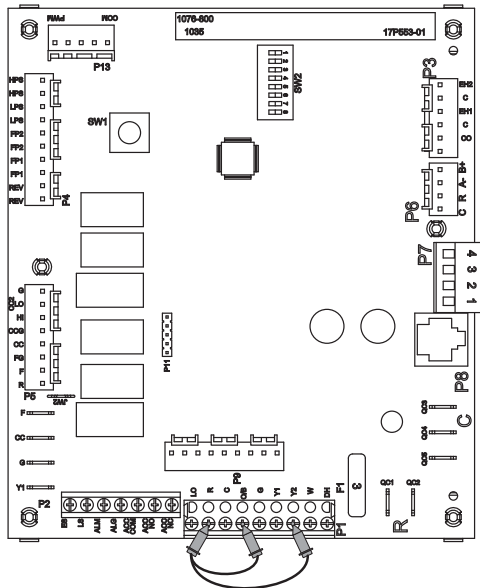

How it works: The condensate sensor is a three part system: a wire, air coil, and water in the drain pan. The wire (spade terminal) and air coil act like a normally open contact and the water acts as the switch. When water in the drain pan fills up and touches the spade terminal, the unit will fault on condensate.

Checking the Sensor: With the AID Tool go to the “Thermostat Inputs” Menu under “Diagnostics” and over-ride the “O” and “Y2” inputs to ON. If an AID Tool is not available remove the P1 connector to disconnect the thermostat from the board and place a jumper wire between “R”, “Y2”, and “O” as shown. Apply power and put the board into test mode by holding SW1 for 2-5 seconds, the green LED will begin a slow flash. Observe the water level in the drain pan. If the unit is locking out on condensate and the drain pan is dry, remove the condensate wire from the drain pan and tape it out of the way. Be careful not to ground the wire out because that will cause the unit to lockout on condensate over flow. If the unit is still locking out, check the brown wire all the way back to the logic board for a short to ground. Remember that the condensate sensor is just a wire looking for a ground. If it touches any metal in the cabinet, the unit will see that as a condensate fault.

If removing the wire from the drain pan stopped the false drain lockouts, put the condensate sensor back in place in the drain pan. Pay close attention to how far the spade terminal sits down in the drain pan. If the terminal is pushed all the way down so that it is touching the bottom of the drain pan, this will cause a condensate lockout if there is any trace of water in the drain pan. If the spade terminal fits loosely in the drain pan, spread the terminal open to make it fit snugly in the drain pan.

## To Check the ECM Blower Motor Enable Signal

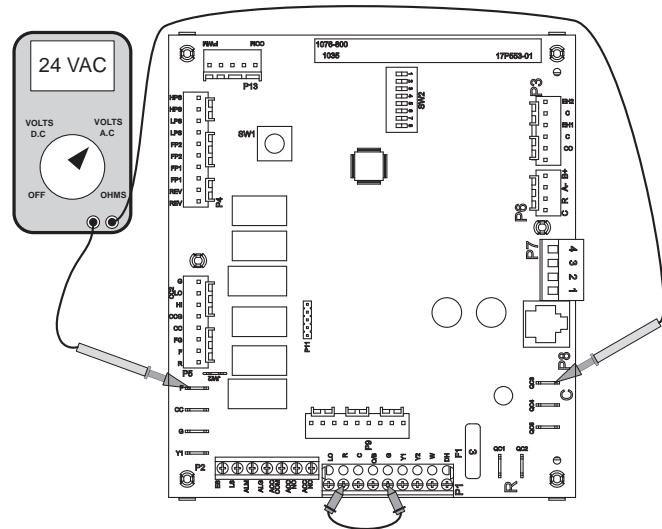

With the AID Tool go to the “Thermostat Inputs” Menu under “Diagnostics” and over-ride the “G” input to ON. If an AID Tool is not available remove the P1 connector to disconnect the thermostat from the board and place a jumper between “R” and “G” as shown. Put the board into test mode by holding SW1 for 2-5 seconds. The blower will come on and run in low speed. To check the enable signal to the motor, measure 24VAC between the F and C terminals.

## To Check the Electric Heat Outputs

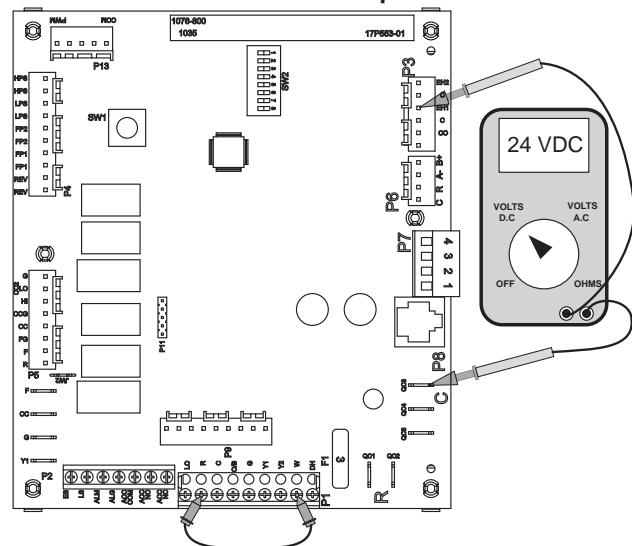

With the AID Tool go to the “Thermostat Inputs” Menu under “Diagnostics” and over-ride the “W” input to ON. If an AID Tool is not available remove the P1 connector to disconnect the thermostat from the board and place a jumper between “R” and “W” as shown. Put the board into test mode by holding SW1 for 2-5 seconds. The blower will come on and run in high speed. 10 seconds later electric heat output 1 (EH1) will be enabled followed by electric heat output 2 (EH2) in 7.5 seconds. Check EH1 by measuring DC volts between “C” and “EH1” and check EH2 by measuring DC volts between “C” and “EH2”.

# Jumping the Control Board

## Stage 1 Heating

With the AID Tool go to the “Thermostat Inputs” Menu under “Diagnostics” and over-ride the “Y1” input to ON. If an AID Tool is not available remove the P1 connector to disconnect the thermostat from the board. Place a jumper between the “R” and “Y1” terminals as shown.

The blower motor will start on low speed immediately the compressor will start 10 seconds later. If the unit is equipped with an ECM blower motor it will switch to medium speed 15 seconds after the Y1 input.

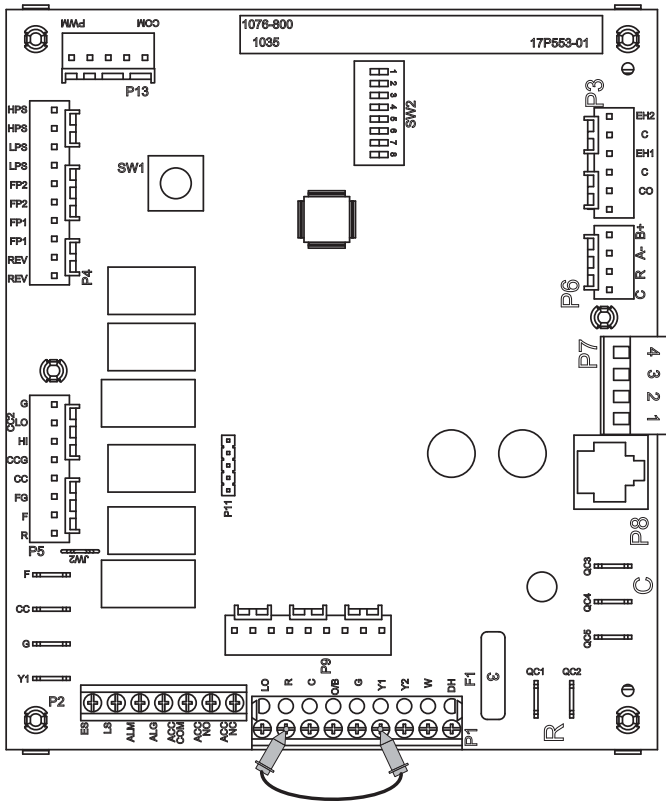

## Stage 2 Heating

With the AID Tool go to the “Thermostat Inputs” Menu under “Diagnostics” and over-ride the “Y1” and “Y2” inputs to ON. If an AID Tool is not available remove the P1 connector to disconnect the thermostat from the board. Place a jumper between the R, Y1, and Y2 terminals as shown.

The blower motor will start on low speed immediately the compressor will start 10 seconds later. If the unit is equipped with an ECM blower motor it will switch to medium speed 15 seconds after the Y1 input. The compressor will stage to full capacity 20 seconds after the compressor starts, and the blower will change to high speed.

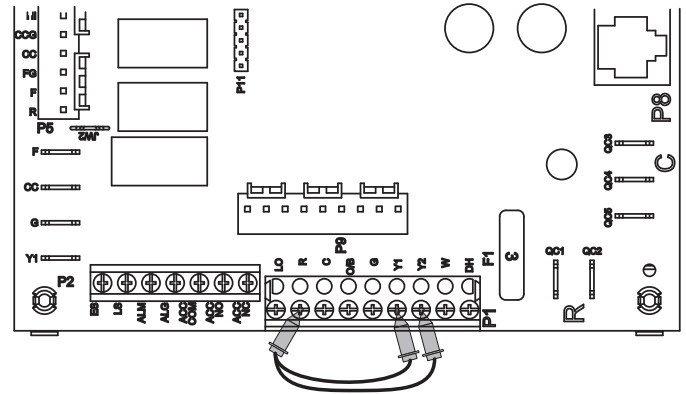

## Stage 3 Heating

With the AID Tool go to the “Thermostat Inputs” Menu under “Diagnostics” and over-ride the “Y1”, “Y2”, and “W” inputs to ON. If an AID Tool is not available remove the P1 connector to disconnect the thermostat from the board. Place a jumper between the R, Y1, Y2 and W terminals as shown.

The blower motor will start on low speed immediately the compressor will start 10 seconds later. If the unit is equipped with an ECM blower motor it will switch to medium speed 15 seconds after the Y1 input. The compressor will stage to full capacity 20 seconds after the compressor starts, and the blower will change to high speed. The first stage of resistance heat is energized and with continuous third stage demand the second stage of resistance heat will engage in 5 minutes.

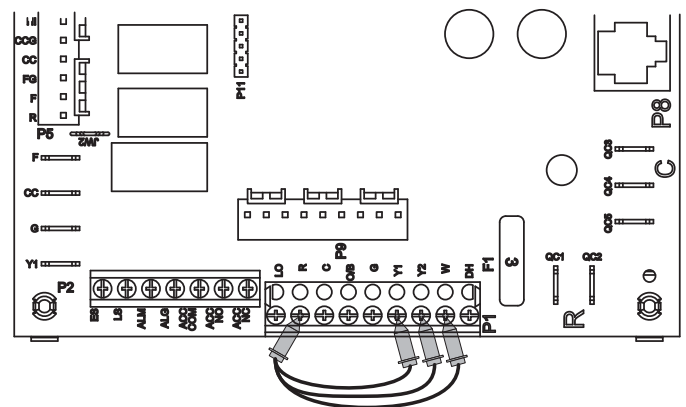

# Jumping the Control Board cont.

## Emergency Heat

With the AID Tool go to the “Thermostat Inputs” Menu under “Diagnostics” and over-ride the “W” input to ON. If an AID Tool is not available remove the P1 connector to disconnect the thermostat from the board. Place a jumper between the “R” and “W” terminals as shown.

The blower will start on high speed and after 20 seconds the first stage of resistance heat is energized. Continuing demand will engage the second stage after 2 minutes.

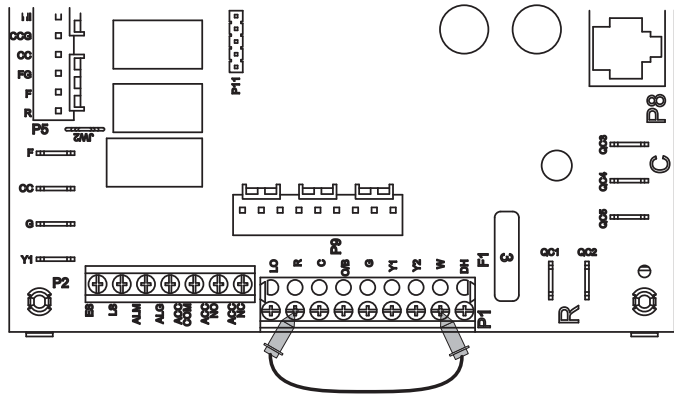

## Blower Only

With the AID Tool go to the “Thermostat Inputs” Menu under “Diagnostics” and over-ride the “G” input to ON. If an AID Tool is not available remove the P1 connector to disconnect the thermostat from the board. Place a jumper between the “R” and “G” terminals as shown.

The blower will start on low speed. Also, regardless of blower speed setting, the blower will remain on low speed for 30 seconds at the end of each heating, cooling, emergency heat, or reheat cycle.

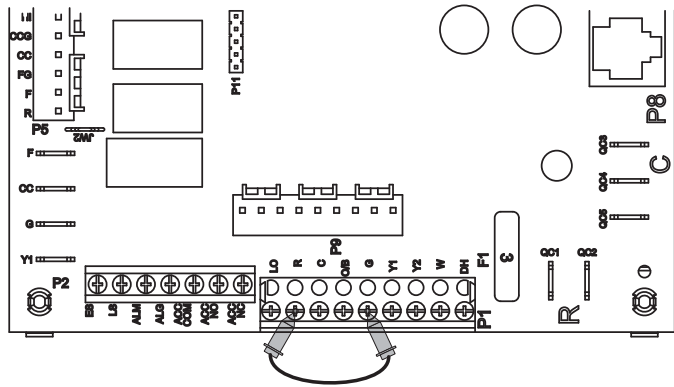

## Stage 1 Cooling

With the AID Tool go to the “Thermostat Inputs” Menu under “Diagnostics” and over-ride the “Y1” and “O” inputs to ON. If an AID Tool is not available remove the P1 connector to disconnect the thermostat from the board. Place a jumper between the R, O, and Y1 terminals as shown.

The blower motor will start on low speed immediately, the compressor will start 10 seconds later. If the unit is equipped with an ECM blower motor it will switch to medium speed 15 seconds after the Y1 input.

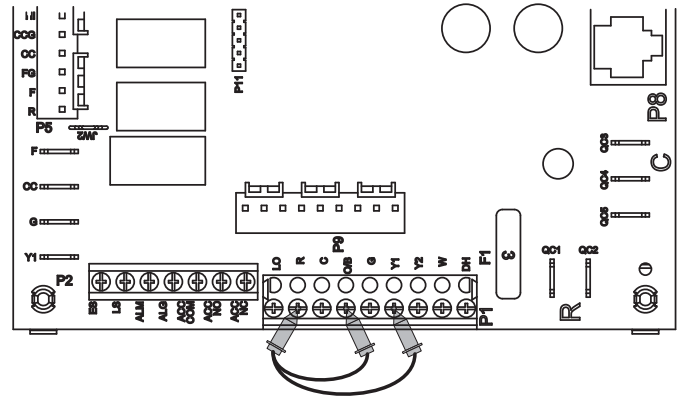

## Stage 2 Cooling

With the AID Tool go to the “Thermostat Inputs” Menu under “Diagnostics” and over-ride the “Y1”, “Y2”, and “O” inputs to ON. If an AID Tool is not available remove the P1 connector to disconnect the thermostat from the board. Place a jumper between the R, O, Y1, and Y2 terminals as shown.

The blower motor will start on low speed immediately the compressor will start 10 seconds later. If the unit is equipped with an ECM blower motor it will switch to medium speed 15 seconds after the Y1 input. The compressor will stage to full capacity 20 seconds after the compressor starts, and the blower will change to high speed.

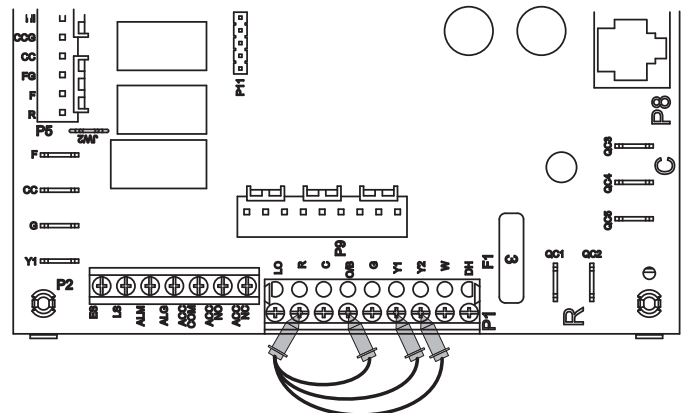

## Jumping the Control Board cont.

### Reheat Mode

With the AID Tool go to the "Thermostat Inputs" Menu under "Diagnostics" and over-ride the "DH" input to ON. If an AID Tool is not available remove the P1 connector to disconnect the thermostat from the board. Place a jumper between the R and DH terminals as shown.

The blower motor will start on low speed immediately the compressor will start 10 seconds later. If the unit is equipped with an ECM blower motor it will switch to medium speed 15 seconds after the DH input. 20 seconds after the DH input is received the compressor will switch to full capacity and the blower motor will switch to dehumidification high speed. 30 seconds after the compressor starts the alarm/reheat output will energize.

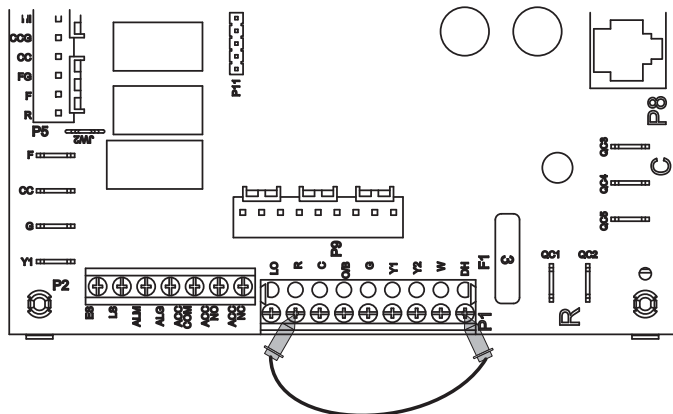

# Water Side Analysis: Heat of Extraction/Rejection

By determining the amount of heat extracted or rejected, the service technician can better judge the performance of the unit and verify whether or not the unit performance is acceptable. Use the following formula to find the heat of extraction/rejection.

## HEAT OF EXTRACTION/REJECTION

$$Q = \text{FLOW} \times \text{FLUID FACTOR} \times \text{TEMP DIFF}$$

$$\text{FLOW} = \text{gpm}$$

$$\text{TEMP DIFF} = \text{Water Rise or Drop in Fahrenheit degrees across the coax}$$

500 = FLUID FACTOR used for water

485 = FLUID FACTOR used for antifreeze solution

**Example:** Entering water temperature of 50°F, leaving water temperature 60.1°F, entering water pressure of 40 psi, leaving water pressure of 34.2 psi, entering air temperature of 70°F, and closed loop (485).

$$\Delta P = 40 \text{ psi} - 34.2 \text{ psi}$$

$$\Delta P = 5.8 \text{ psi}$$

Convert  $\Delta P$  to psi using pressure drop table in equipment install manual. A  $\Delta P$  of 5.8 psi equals 9 gpm.

$$Q = 9 \text{ gpm} \times 485 \times 10.1^\circ\text{F}$$

$$Q = 44,087 \text{ Btu/hr}$$

Next, find the Heat of Extraction/Rejection Data for the example unit. Match the entering water temperature at 9 gpm. Now, move to the right and read the number under "HR" and compare listed capacity data with actual performance. Note that the example calculation is within 4,800 Btu/hr of the listed HE. The actual heat of extraction/rejection should be within 10% of catalog data. If the actual heat of extraction/rejection is less than 90% of catalog data, a further refrigeration check of the unit will be necessary to determine if the unit is charged properly, has a faulty component, or needs adjustment.

## Example Unit Data Tables

### Pressure Drop

Model	gpm	Pressure Drop (psi)				
		30°F	50°F	70°F	90°F	110°F
Example	5.0	1.4	1.1	0.9	0.7	0.5
	7.0	2.5	2.3	2.1	1.8	1.6
	9.0	6.0	5.8	5.5	5.3	5.1
	12.0	6.6	6.4	6.2	6.0	5.7

### Heat of Extraction/Rejection

Model	gpm	Heat of Extraction (HE)				Heat of Rejection (HR)				
		30°F	50°F	70°F	90°F	30°F	50°F	70°F	90°F	110°F
Example	5.0		24.6	33.0	41.7		47.4	45.3	44.1	
	7.0	19.0	25.7	34.3	42.4	41.5	47.7	45.8	44.2	42.4
	9.0	19.6	26.8	35.5	43.1	41.7	48.1	46.3	44.6	42.7

# Superheat/Subcooling

## Checking Superheat in the Heating Mode

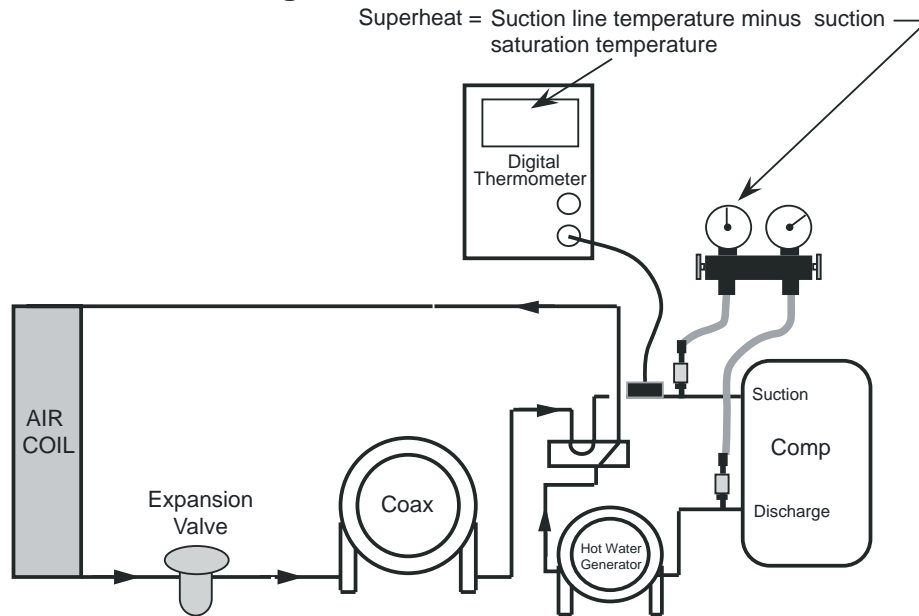

## Checking Superheat in the Cooling Mode

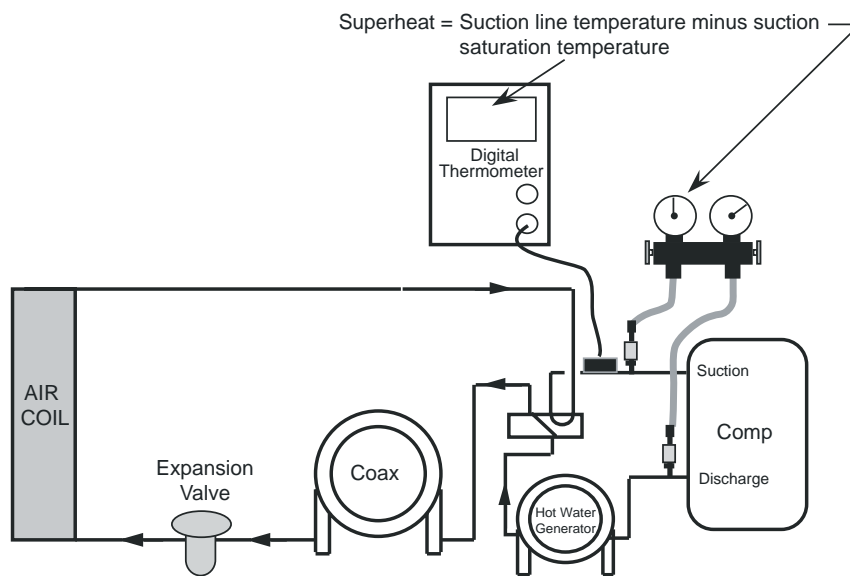

**NOTE:** Always turn hot water generator off during these tests.

1. Always check water and airflow before putting gages on the unit.
2. Determine superheat and compare with the values shown in the table.
3. If superheat is HIGH, there may be a restriction in the TXV assembly, low charge, or the TXV bulb may have lost its charge. Also check entering air and water temperatures.
4. If superheat is HIGH and subcooling is LOW, the unit may be undercharged.

Entering Water Temperature	Heating		Cooling	
	Superheat	Subcooling	Superheat	Subcooling
030	9-14	5-9	25-35	15-25
050	10-14	5-9	10-18	15-25
070	12-16	5-8	9-14	13-18
090	N/A	N/A	8-13	13-18

Based on nominal 400 cfm per ton airflow and 80°F EAT cooling and 70°F EAT heating. Cooling air and water numbers can vary greatly with changes in humidity.

# Superheat/Subcooling cont.

## Checking Subcooling in the Heating Mode

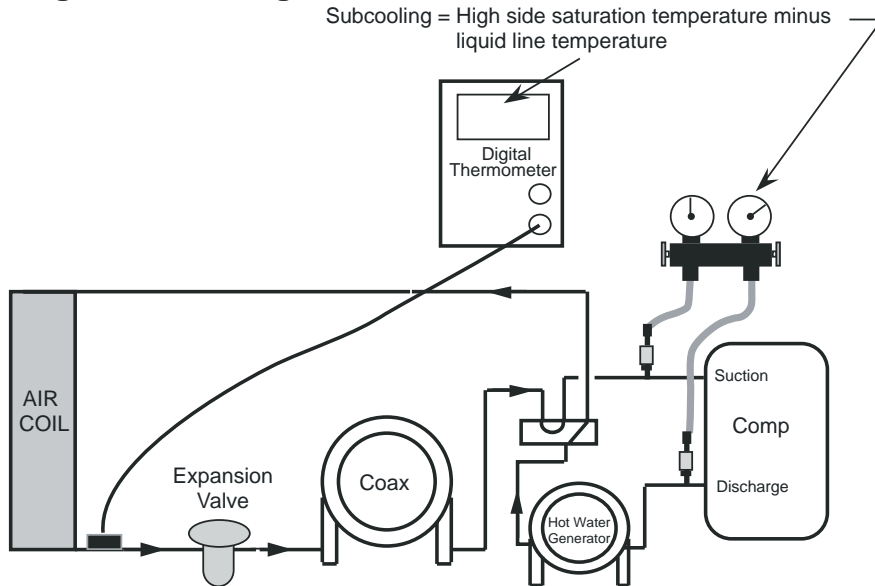

## Checking Subcooling in the Cooling Mode

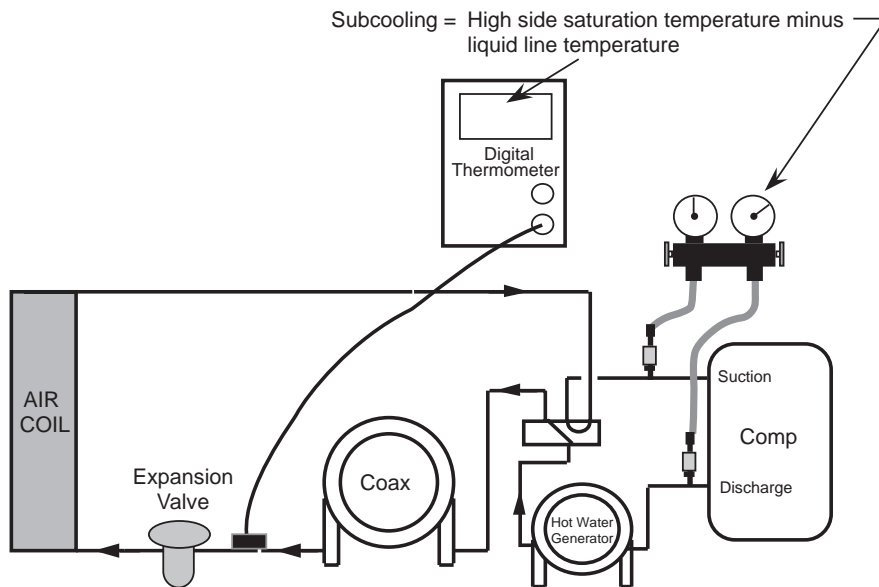

**NOTE:** Always turn hot water generator off during these tests.

1. Always check water and airflow before putting gages on the unit.
2. Determine subcooling and compare with the values shown in the table.
3. If superheat is HIGH, there may be a restriction in the TXV assembly, low charge, or the TXV bulb may have lost its charge. Also check entering air and water temperatures.
4. If superheat is HIGH and subcooling is LOW, the unit may be undercharged.

Entering Water Temperature	Heating		Cooling	
	Superheat	Subcooling	Superheat	Subcooling
030	9-14	5-9	25-35	15-25
050	10-14	5-9	10-18	15-25
070	12-16	5-8	9-14	13-18
090	N/A	N/A	8-13	13-18

Based on nominal 400 cfm per ton airflow and 80°F EAT cooling and 70°F EAT heating. Cooling air and water numbers can vary greatly with changes in humidity.

## Revision Guide

---

<b>Pages:</b>	<b>Description:</b>	<b>Date:</b>	<b>By:</b>
All	Misc. updates for Aurora Toolbox	3 Oct 2016	MA
All	First Published	10 Oct 2012	DS



Product: **Aurora Base Control (ABC) Standard  
Version 1.02**

Document Type: Application and Troubleshooting Guide  
Part Number: AG1562EW  
Release Date: 10/16