

5 Series

502W12

High Temp Hydronic Geothermal Heat Pump

- R-134a Refrigerant
- 7 Ton Dual Capacity

Installation Information

Water Piping Connections

Electrical Data

Microprocessor Control

Startup Procedures

Preventive Maintenance



Table of Contents

Model Nomenclature	4
General Installation Information	5
Field Connected Water Piping	6
Typical Application Piping	8
Water Quality	9
Dimensional Data	10
Physical Data	11
Electrical Data	11
Wiring Schematics	12
Field Wiring and Control Setup	17
Control Features	18
Sequence of Operation	20
Inputs and Outputs Configuration	21
Unit Display and Interface	21
Reference Calculations	24
Legend	24
Unit Startup	24
Operating Parameters	25
Load and Source Pressure Drop	25
Thermistor Resistance	26
Heat of Extraction/Rejection Data	26
Compressor Resistance	26
Heating/Cooling Cycle Analysis	27
Startup and Troubleshooting Form	28
Troubleshooting	29
Preventive Maintenance	29
Service Parts List	30
Revision Guide	31

Model Nomenclature

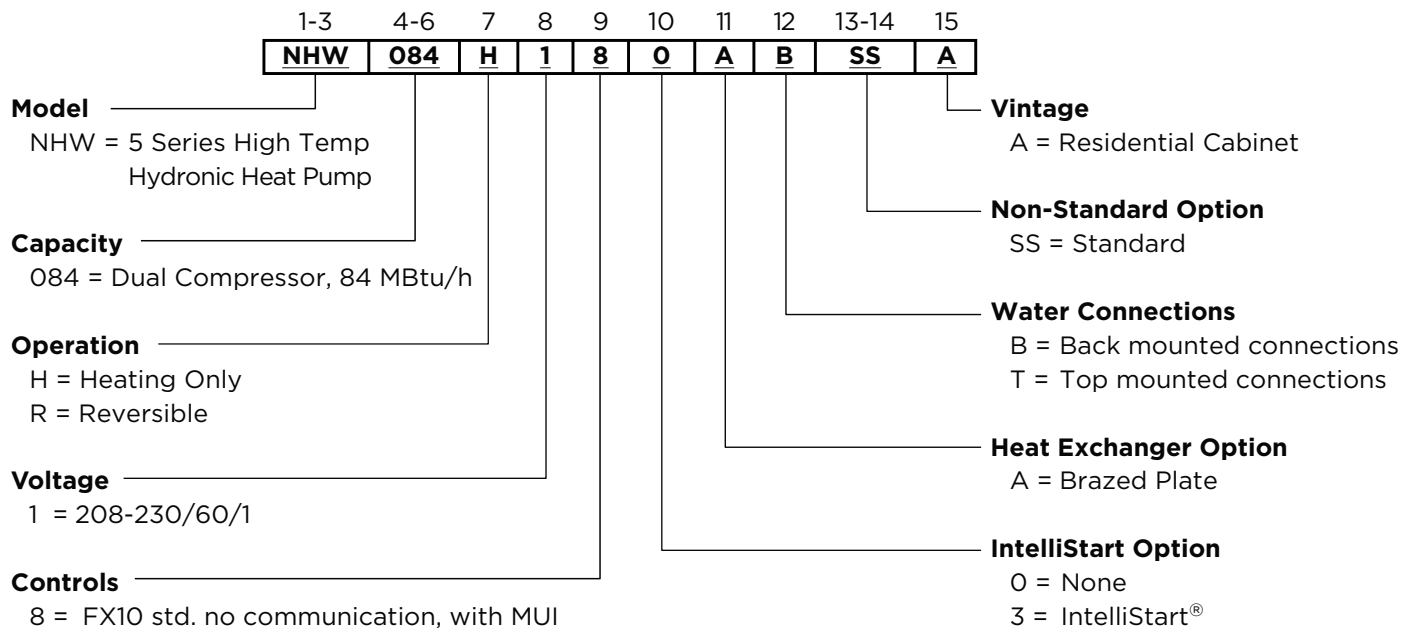

NOTE: MUI = Medium User Interface



All 5 Series 502W12 product is safety listed under UL1995 thru ETL and performance listed with AHRI in accordance with standard 13256-2. The 5 Series 502W12 is also Energy Star rated.

General Installation Information

Safety Considerations

Installing and servicing air conditioning and heating equipment can be hazardous due to system pressure and electrical components. Only trained and qualified service personnel should install, repair or service heating and air conditioning equipment. When working on heating and air conditioning equipment, observe precautions in the literature, tags and labels attached to the unit and other safety precautions that may apply.

Follow all safety codes. Wear safety glasses and work gloves. Use quenching cloth for brazing operations. Have fire extinguisher available for all brazing operations.

NOTE: Before installing, check voltage of unit(s) to ensure proper voltage.



WARNING: Before performing service or maintenance operations on the system, turn off main power switches to the unit. Electrical shock could cause serious personal injury.



WARNING: This heat pump is capable of producing hot water up to 150°F. All exposed piping surfaces shall be insulated to prevent serious personal injury that can occur from touching water piping.

Application

Units are not intended for heating domestic (potable) water or swimming pools by direct coupling. If used for this type of application, a secondary heat exchanger must be used.

Moving and Storage

Move units in the normal "Up" orientation as indicated by the labels on the unit packaging. When the equipment is received, all items should be carefully checked against the bill of lading to ensure that all crates and cartons have been received in good condition. Examine units for shipping damage, removing unit packaging if necessary to properly inspect unit. Units in question should also be internally inspected. If any damage is observed, the carrier should make the proper notation on delivery receipt acknowledging the damage. Units are to be stored in a location that provides adequate protection from dirt, debris and moisture.



WARNING: To avoid equipment damage, do not leave the system filled in a building without heat during cold weather, unless adequate freeze protection levels of antifreeze are used. Heat exchangers do not fully drain and will freeze unless protected, causing permanent damage.

Unit Location

Provide sufficient room to make water and electrical connections. If the unit is located in a confined space, provisions must be made for unit servicing. Locate the unit in an indoor area that allows easy removal of the access panels and has enough space for service personnel to perform maintenance or repair. These units are not approved for outdoor installation and, therefore, must be installed inside the structure being conditioned. Do not locate units in areas subject to freezing conditions.



WARNING: Do not store or install units in corrosive environments or in locations subject to temperature or humidity extremes (e.g. attics, garages, rooftops, etc.). Corrosive conditions and high temperature or humidity can significantly reduce performance, reliability, and service life.



WARNING: To avoid equipment damage and possible voiding of warranty, be sure that properly sized strainers are installed upstream of both brazed plate heat exchangers to protect them against particles in the fluid.

Mounting Units

Prior to setting the unit in place, remove and discard both compressor hold down shipping bolts located at the front of each compressor mounting bracket. Units should be mounted level on a vibration absorbing pad slightly larger than the base to provide isolation between the unit and the floor. It is not necessary to anchor the unit to the floor. Allow access to the front, back, and side access panels for servicing.

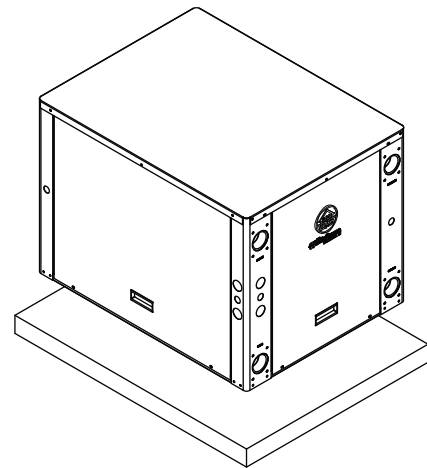

Vibration Pad Mounting

Field Connected Water Piping

General

Each unit is equipped with captive 1-1/4 in. [31.8 mm] FPT water connections to eliminate 'egg-shaping' from use of a backup wrench. For making the water connections to the unit, a Teflon tape thread sealant is recommended to minimize internal fouling of the piping. Do not over tighten connections.

NOTE: Units are factory run-tested using propylene glycol. Prior to connecting piping to unit, thoroughly flush heat exchangers.

The piping installation should provide service personnel with the ability to measure water temperatures and pressures. The water lines should be routed so as not to interfere with access to the unit. The use of a short length of high pressure hose with a swivel type fitting may simplify the connections and prevent vibration.

Before final connection to the unit, the supply and return hose kits must be connected, and the system flushed to remove dirt, piping chips and other foreign material. Normally, a combination balancing and close-off (ball) valve is installed at the return, and a rated gate or ball valve is installed at the supply. The return valve can be adjusted to obtain the proper water flow. The valves allow the unit to be removed for servicing. Both source as well as load fluid piping must be at least as large as the unit connections on the heat pump (larger on long runs).

Never use flexible hoses of a smaller inside diameter than that of the water connection on the unit and limit hose length to 10 ft. per connection. Check carefully for water leaks.

Load and Source Piping Connections

The 5 Series 502W12 has two connection options available. Each kit is intended to connect one piping connection. Therefore, two kits will be required for each unit. The kits can be mixed for installer convenience, one on source and the other on load.

- **CK5L** - Kit includes a pair of forged brass street elbows (1-1/4 in. MPT x 1-1/4 in. hose barb) with 1/4 in. pressure/temperature plugs
- **CK5L-XL** - 1-1/4 in. rubber hose kit includes CK5L plus two 8 ft. pieces of 1-1/4 in. rubber hose, a pair of 1-1/4 in. hose barb x 1-1/4 in. XL style fittings, and stainless steel hose clamps
- **CK5L-XLS** - 1-1/4 in. rubber hose kit includes all the same items from CK5L-XL plus 1-1/4 in. 20 mesh bronze strainer



WARNING: All field installed piping and piping connections must be rated for temperatures greater than 160°F. Materials such as PVC, CPVC, and DWV shall not be used.

Water Flow Rate

The proper water flow must be delivered to each unit whenever the unit heats or cools. To assure proper flow, the use of pressure/temperature ports is recommended to determine the flow rate. These ports should be located adjacent to the supply and return connections on the unit. The proper flow rate cannot be accurately set without measuring the water pressure drop through the refrigerant-to-water heat exchanger (See Pressure Drop Table for water flow and pressure drop information).

Load Flow Rate

The load flow on the 5 Series 502W12 should be 20 gpm (typically the rated flow). Refer to the table below. This flow rate is required especially when heating water to limit the effects of the higher condensing temperatures of water heating for radiant floor heating or domestic water use.

Source Flow Rate

The source flow can range between 15 and 25 gpm for earth loops. For open loop well water systems the minimum flow should be 15 gpm. In earth loop systems where entering water temperatures are expected to be above 95°F, 25 gpm should be used. In well systems where the water temperature is below 50°F, 20 gpm should be used to avoid nuisance freeze detection trips.

Model	Source Flow Rate (gpm)			Load Flow Rate (gpm)
	Minimum Open Loop	Open Loop < 50°F	Closed Loop Range (Min - Full Flow)	
NHW084	15	20	20 25	25

Flushing

Flushing the system of debris is especially important in brazed plate heat exchanger systems. These systems have many small parallel flow paths in which debris can clog. Initial flushing of the system can be accomplished in one of two ways. First flushing the piping system toward the strainer will allow the strainers to capture all debris prior the heat exchangers and commissioning. Secondly a temporary bypass can be included in the piping design so that the heat pump itself can be bypassed during the initial flushing stage with an external strainer gathering the debris.



CAUTION: Water piping exposed to outside temperature may be subject to freezing.

Field Connected Water Piping cont.

Open Loop Well Water Systems

Installation of an open loop system is not recommended unless water quality guidelines are met.

Earth Coupled Systems

All supply and return water piping should be insulated to prevent excess condensation from forming on the water lines. Ensure pumping system is capable of providing adequate flow rate at the system pressure drop, 25 gpm [1.58 L/s] (source side) is recommended. Antifreeze in the loop is strongly recommended.

Heating with High Source Temperatures

Heating water with a water to water unit using high source temperatures can lead to operating conditions that fall outside of the system operating range. The condition occurs when the loop (source) temperature exceeds 70°F [21.1°C] with a full flow of 25 gpm [1.58 L/s]. Under this scenario, the evaporating temperature can fall outside of the compressor operating window.

To allow the system to operate correctly, restricting the source side flow when the evaporating temperature exceeds 55°F [12.7°C] is recommended. One way of accomplishing this is to use a flow-restricting valve on the source loop circuit that is controlled by the evaporating temperature. Locate the sensing device on the refrigerant inlet of the evaporator. In dual circuit systems, the company recommends monitoring both circuits and controlling off the sensor that reads the highest temperature.

As an alternative to the evaporating temperature, the suction line temperature can be monitored with the same control capability. In this control, temperature should be a maximum of 65°F [18.3°C].

A kit is available for this application, contact WaterFurnace for support.

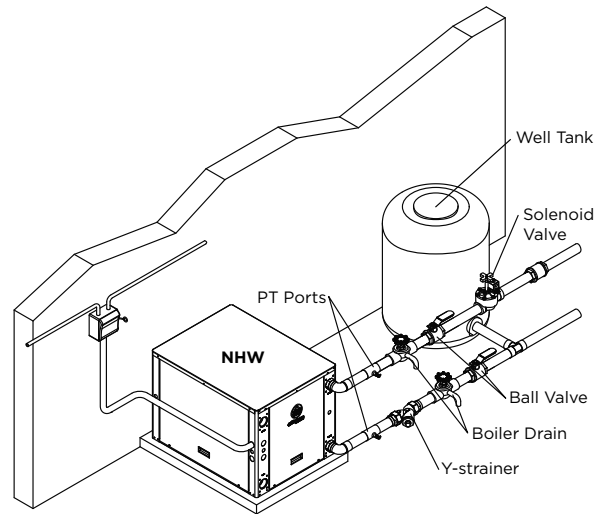

Open Loop Well Water Systems

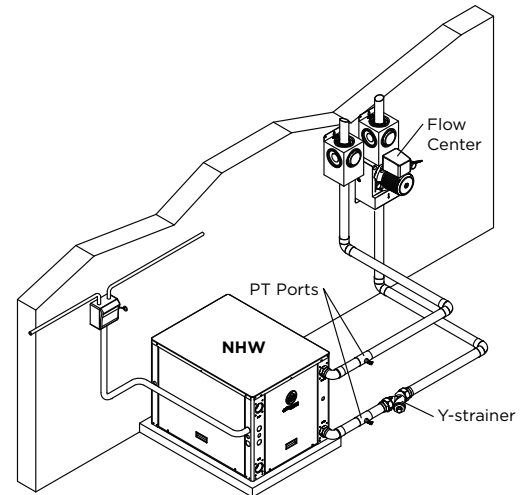

Earth Coupled Systems

Typical Application Piping

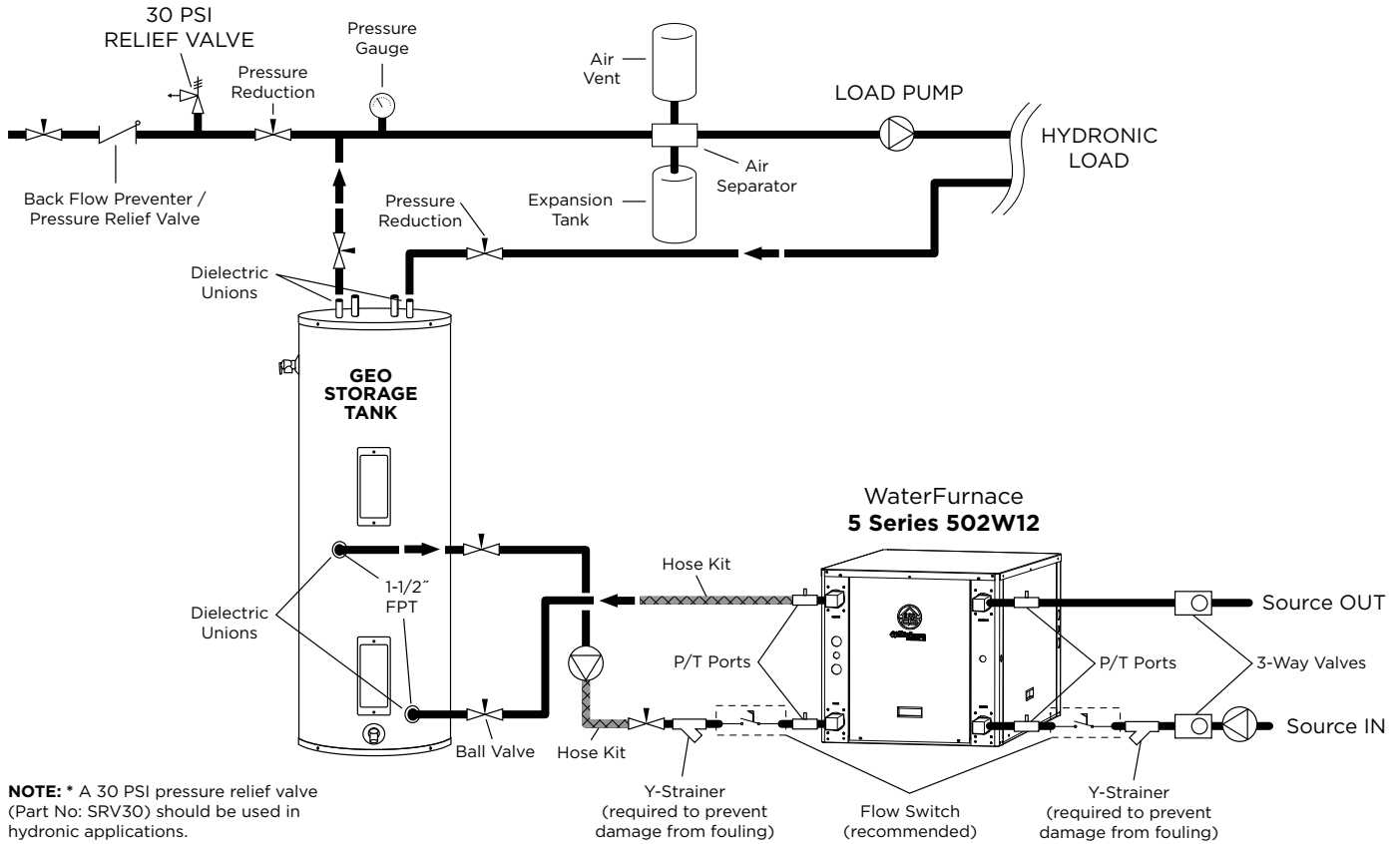

WARNING: When using a water storage tank thermostat the tank temperature should not be set higher than the maximum entering water temperature of the heat pump. This will limit the possibility of the heat pump from operating outside of the performance table.

Water Quality

General

Reversible chiller systems may be successfully applied in a wide range of commercial and industrial applications. It is the responsibility of the system designer and installing contractor to ensure that acceptable water quality is present and that all applicable codes have been met in these installations.

Water Treatment

Do not use untreated or improperly treated water. Equipment damage may occur. The use of improperly treated or untreated water in this equipment may result in scaling, erosion, corrosion, algae or slime. The services of a qualified water treatment specialist should be engaged to determine what treatment, if any, is required. The product warranty specifically excludes liability for corrosion, erosion or deterioration of equipment.

The heat exchangers in the units are 316 stainless steel plates with copper brazing. The water piping in the heat exchanger is steel. There may be other materials in the building's piping system that the designer may need to take into consideration when deciding the parameters of the water quality.

If an antifreeze or water treatment solution is to be used, the designer should confirm it does not have a detrimental effect on the materials in the system.

Contaminated Water

In applications where the water quality cannot be held to prescribed limits, the use of a secondary or intermediate heat exchanger is recommended to separate the unit from the contaminated water.

The following table outlines the water quality guidelines for unit heat exchangers. If these conditions are exceeded, a secondary heat exchanger is required. Failure to supply a secondary heat exchanger where needed will result in a warranty exclusion for primary heat exchanger corrosion or failure.

Strainers

These units must have properly sized strainers upstream of both brazed plate heat exchangers to protect them against particles in the fluid. Failure to install proper strainers and perform regular service can result in serious damage to the unit, and cause degraded performance, reduced operating life and failed compressors. Improper installation of the unit (which includes not having proper strainers to protect the heat exchangers) can also result in voiding the warranty.

Field supplied strainers with 420-840 microns are recommended, with 500 microns being the optimum choice. The strainers selected should have a mesh open area of at least 39 cm² for each unit being serviced by the strainer. Using strainers with a smaller amount of open area will result in the need for more frequent cleaning.

Strainers should be selected on the basis of acceptable pressure drop, and not on pipe diameter. The strainers selected should have a pressure drop at the nominal flow rate of the units; low enough to be within the pumping capacity of the pump being used.



WARNING: Must have intermediate heat exchanger when used in pool applications.

Water Quality Guidelines

Material		Copper	90/10 Cupronickel	316 Stainless Steel
pH	Acidity/Alkalinity	7 - 9	7 - 9	7 - 9
Scaling	Calcium and Magnesium Carbonate	(Total Hardness) less than 350 ppm	(Total Hardness) less than 350 ppm	(Total Hardness) less than 350 ppm
Corrosion	Hydrogen Sulfide	Less than 0.5 ppm (rotten egg smell appears at 0.5 ppm)	10 - 50 ppm	Less than 1 ppm
	Sulfates	Less than 125 ppm	Less than 125 ppm	Less than 200 ppm
	Chlorine	Less than 0.5 ppm	Less than 0.5 ppm	Less than 0.5 ppm
	Chlorides	Less than 20 ppm	Less than 125 ppm	Less than 300 ppm
	Carbon Dioxide	Less than 50 ppm	10 - 50 ppm	10 - 50 ppm
	Ammonia	Less than 2 ppm	Less than 2 ppm	Less than 20 ppm
	Ammonia Chloride	Less than 0.5 ppm	Less than 0.5 ppm	Less than 0.5 ppm
	Ammonia Nitrate	Less than 0.5 ppm	Less than 0.5 ppm	Less than 0.5 ppm
	Ammonia Hydroxide	Less than 0.5 ppm	Less than 0.5 ppm	Less than 0.5 ppm
	Ammonia Sulfate	Less than 0.5 ppm	Less than 0.5 ppm	Less than 0.5 ppm
	Total Dissolved Solids (TDS)	Less than 1000 ppm	1000 - 1500 ppm	1000 - 1500 ppm
	LSI Index	+0.5 to -0.5	+0.5 to -0.5	+0.5 to -0.5
Iron Fouling (Biological Growth)	Iron, FE ²⁺ (Ferrous) Bacterial Iron Potential	< 0.2 ppm	< 0.2 ppm	< 0.2 ppm
	Iron Oxide	Less than 1 ppm, above this level deposition will occur	Less than 1 ppm, above this level deposition will occur	Less than 1 ppm, above this level deposition will occur
Erosion	Suspended Solids	Less than 10 ppm and filtered for max. of 600 micron size	Less than 10 ppm and filtered for max. of 600 micron size	Less than 10 ppm and filtered for max. of 600 micron size
	Threshold Velocity (Fresh Water)	< 1.8 m/sec	< 1.8 m/sec	< 1.8 m/sec

NOTES: Grains = ppm divided by 17
mg/L is equivalent to ppm

2/22/12

Dimensional Data

NHW084 - Top Waterline Configuration

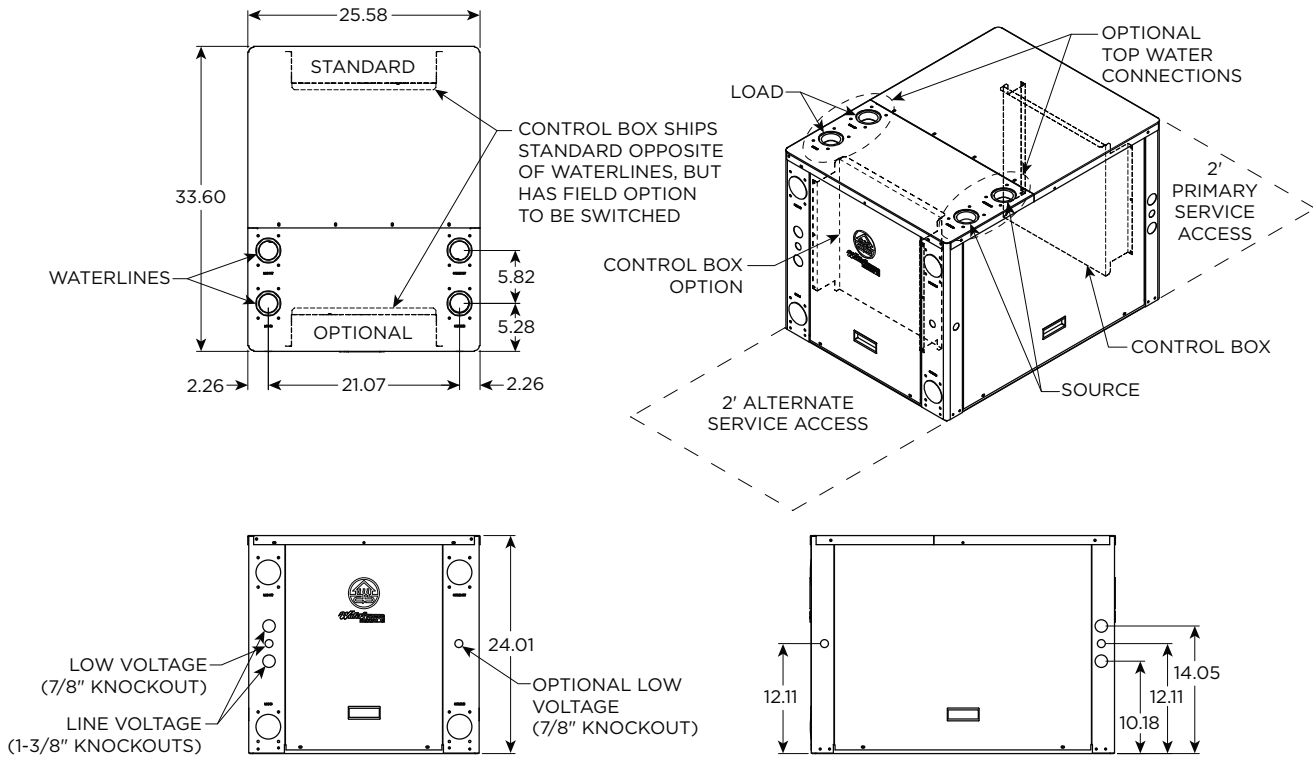

NHW084 - Back Waterline Configuration

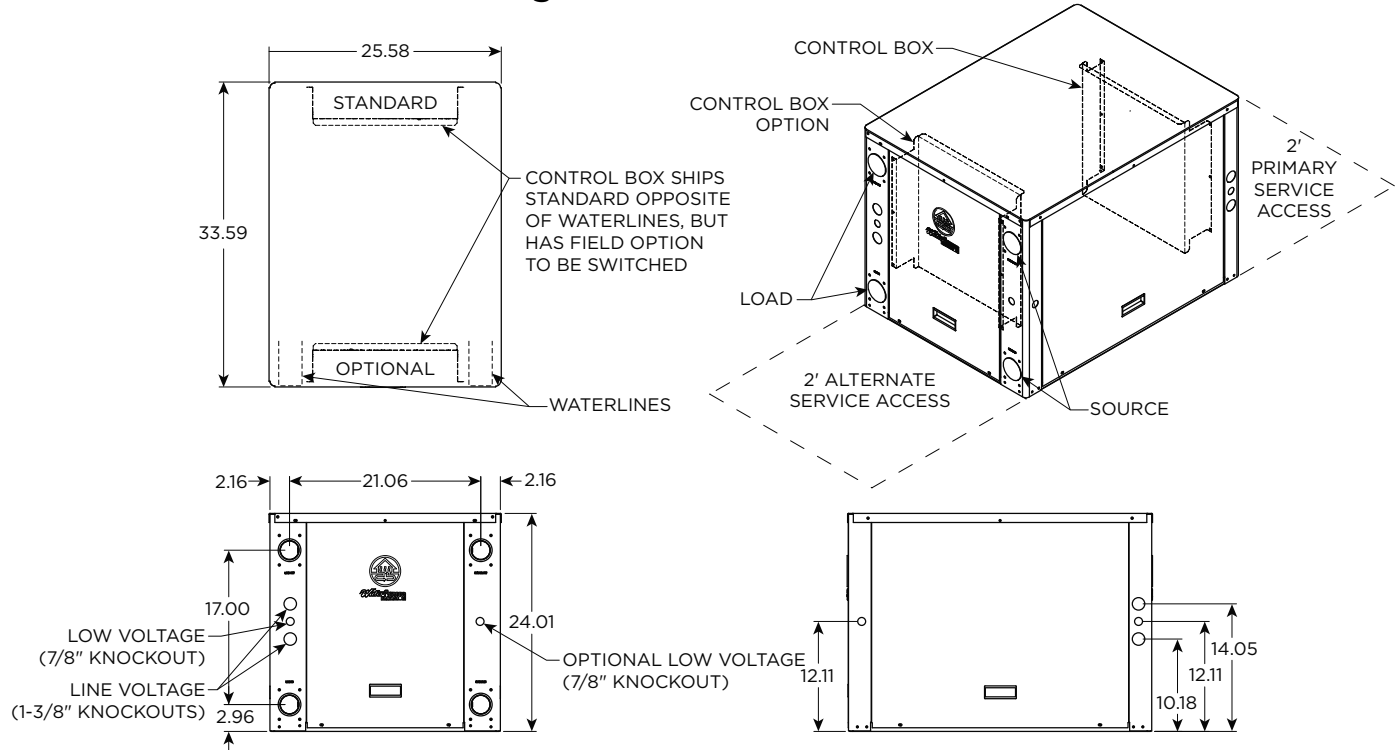

Physical Data

Model	084
Compressor (2 each)	Scroll
Factory Charge R-134a, oz [kg]	76 [2.16]
Load Water Connection	
FPT - in	1.25
Source Water Connection	
FPT - in	1.25
Weight - Operating, lb [kg]	420 [190]
Weight - Packaged, lb [kg]	415 [188]

2/14/12

Electrical Data

Model	Supply Circuit	Rated Voltage	Voltage Min/Max	Compressor*				Load Pump FLA	Source Pump FLA	Total Unit FLA	Min Circ Amp	Max Fuse/HACR
				MCC	RLA	LRA	LRA**					
084	L1/L2	208-230/60/1	187/253	37.0	23.7	144.0	65.0	-	-	23.7	29.6	50
	L3/L4	208-230/60/1	187/253	37.0	23.7	144.0	65.0	4.2	4.2	32.1	38.0	60

HACR circuit breaker in USA only

* Ratings per each compressor - unit supplied with two

** With optional IntelliStart

2/14/12

Figure 1 - Control Box

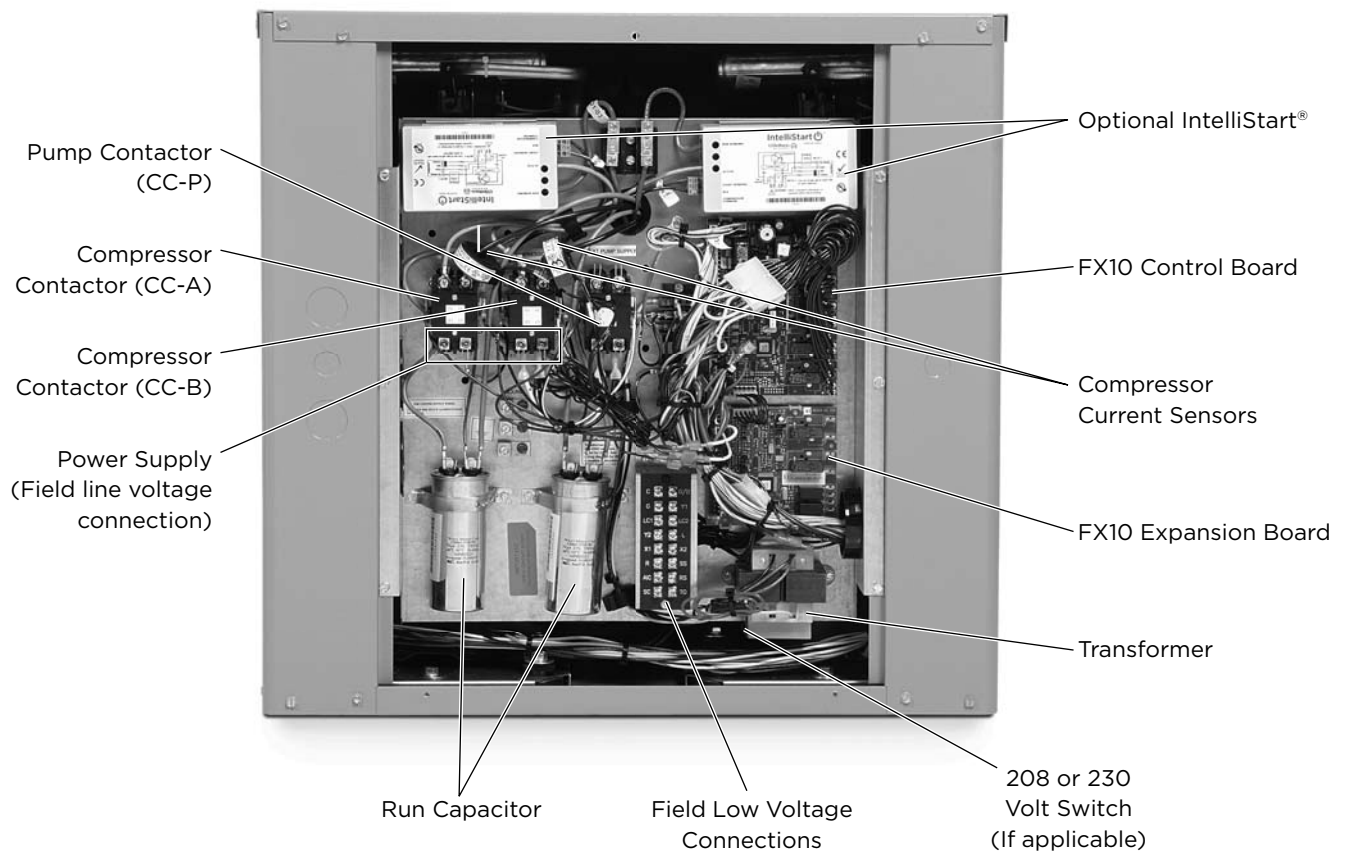

Wiring Schematics cont.

208-230/60/1

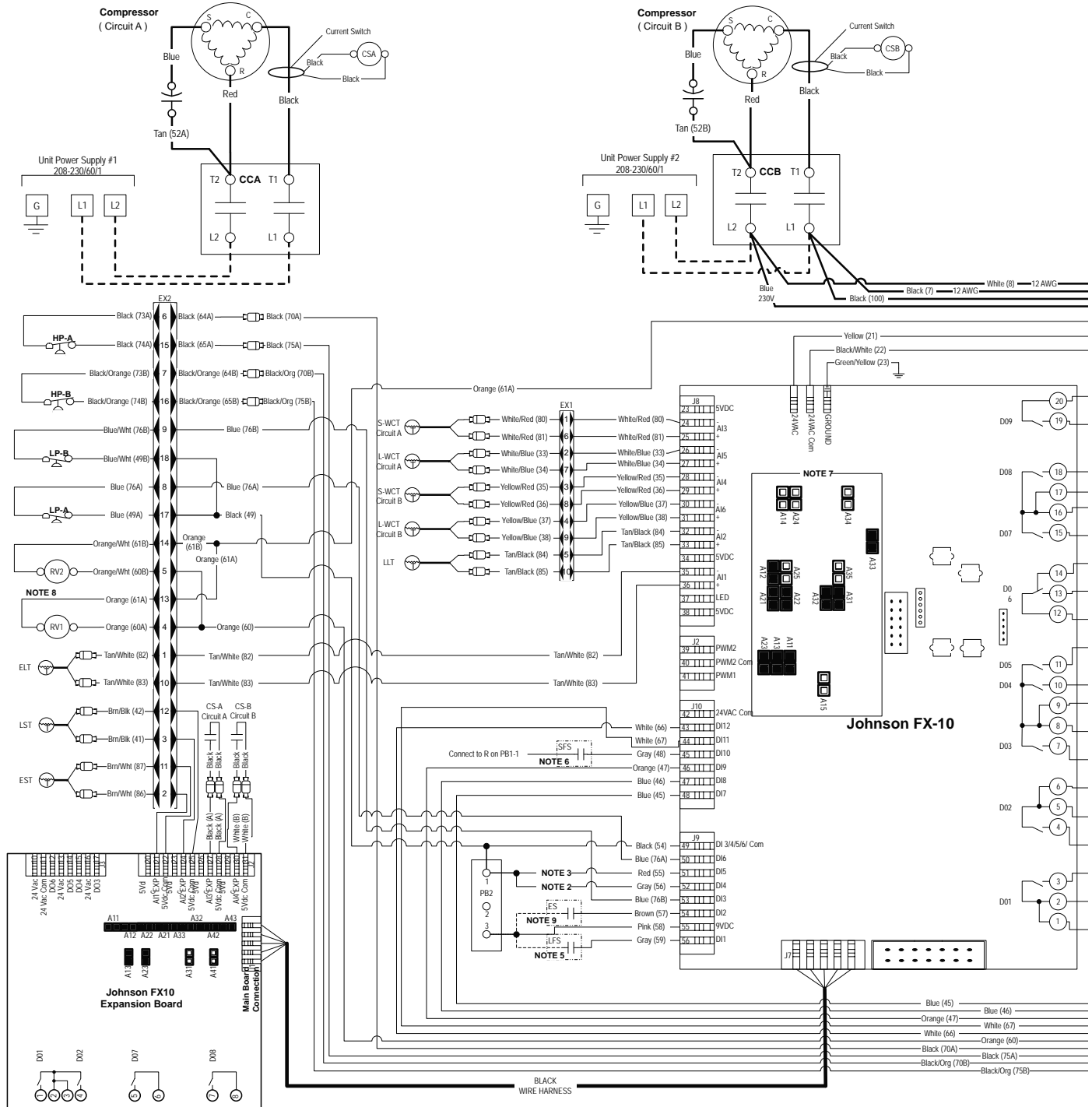

Wiring Schematics cont.

208-230/60/1 cont.

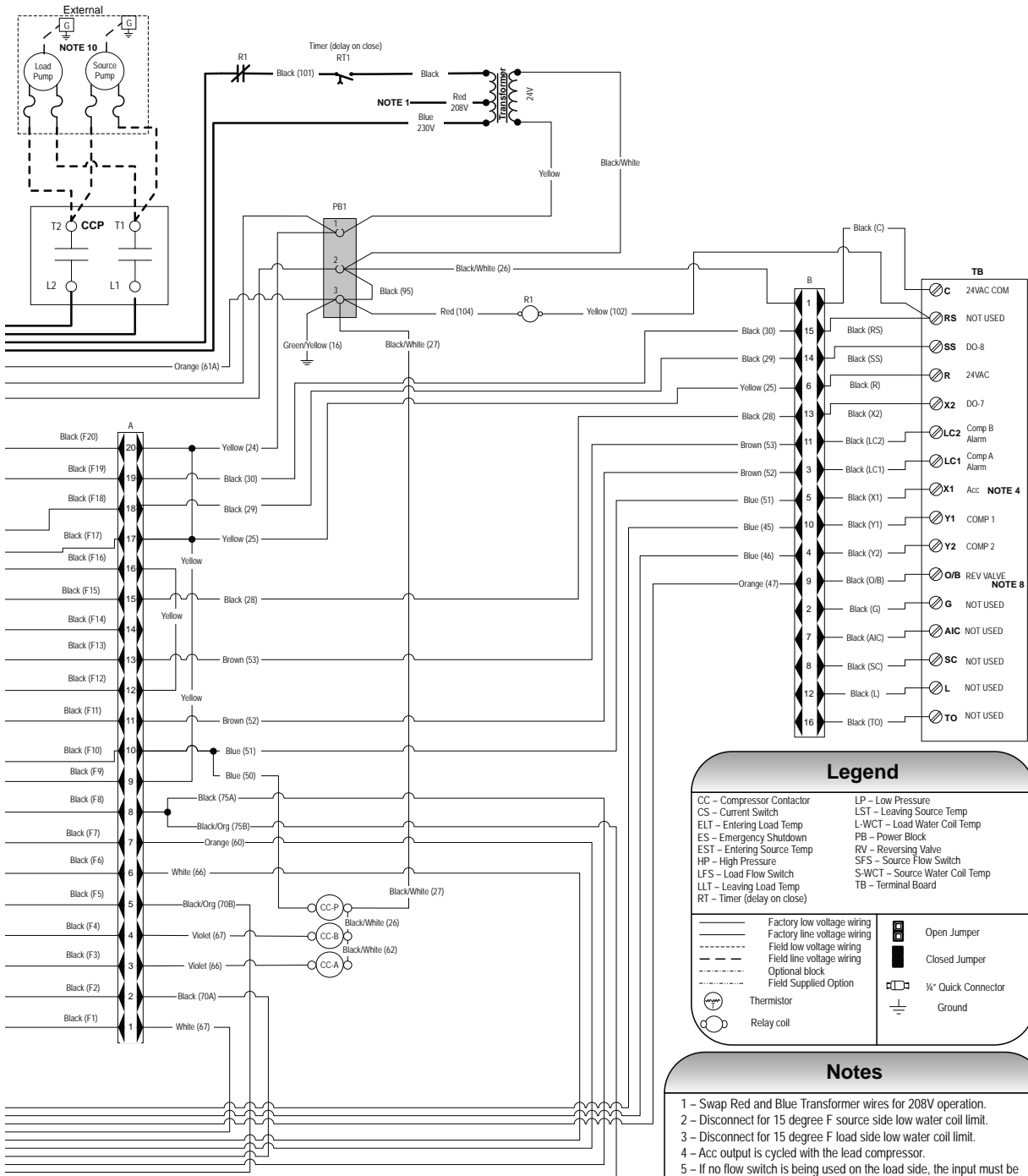

Legend

CC - Compressor Contactor	LP - Low Pressure
CS - Current Switch	LST - Leaving Source Temp
ELT - Entering Load Temp	L-WCT - Load Water Coil Temp
ES - Emergency Shutdown	PB - Power Block
EST - Entering Source Temp	RV - Reversing Valve
HP - High Pressure	SFS - Source Flow Switch
LFS - Load Flow Switch	S-WCT - Source Water Coil Temp
LLT - Leaving Load Temp	TB - Terminal Board
RT - Timer (delay on close)	

Factory low voltage wiring	Open Jumper
Factory line voltage wiring	Closed Jumper
Field low voltage wiring	1/4" Quick Connector
Field line voltage wiring	Ground
Optional block	
Field Supplied Option	
Thermistor	
Relay coil	

Notes

- 1 - Swap Red and Blue Transformer wires for 208V operation.
- 2 - Disconnect for 15 degree F source side low water coil limit.
- 3 - Disconnect for 15 degree F load side low water coil limit.
- 4 - Acc output is cycled with the lead compressor.
- 5 - If no flow switch is being used on the load side, the input must be jumpered to PB2-3 for the unit to operate.
- 6 - If no flow switch is being used on the source side, the input must be jumpered to R on PB1-1 for the unit to operate.
- 7 - Jumpers must be set as shown for correct control operation. If a communication card is present, it must be removed to verify jumper settings.
- 8 - The reversing valve will be energized for cooling mode.
- 9 - Used for Emergency Shutdown in conjunction with a normally open relay.
- 10 - External load and source pumps must be externally fused.

Wiring Schematics cont.

208-230/60/1 with IntelliStart

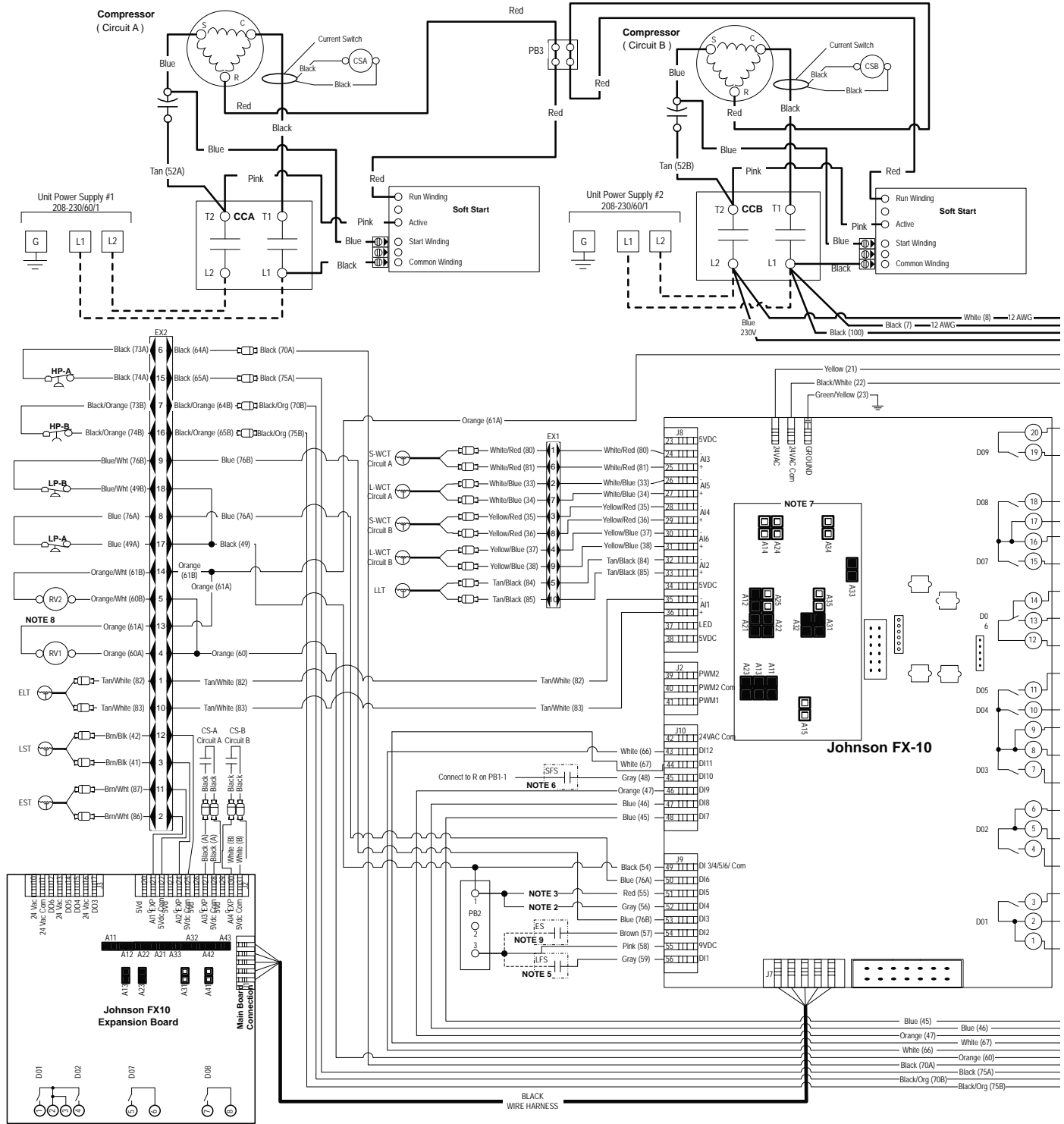

Wiring Schematics cont.

208-230/60/1 with IntelliStart cont.

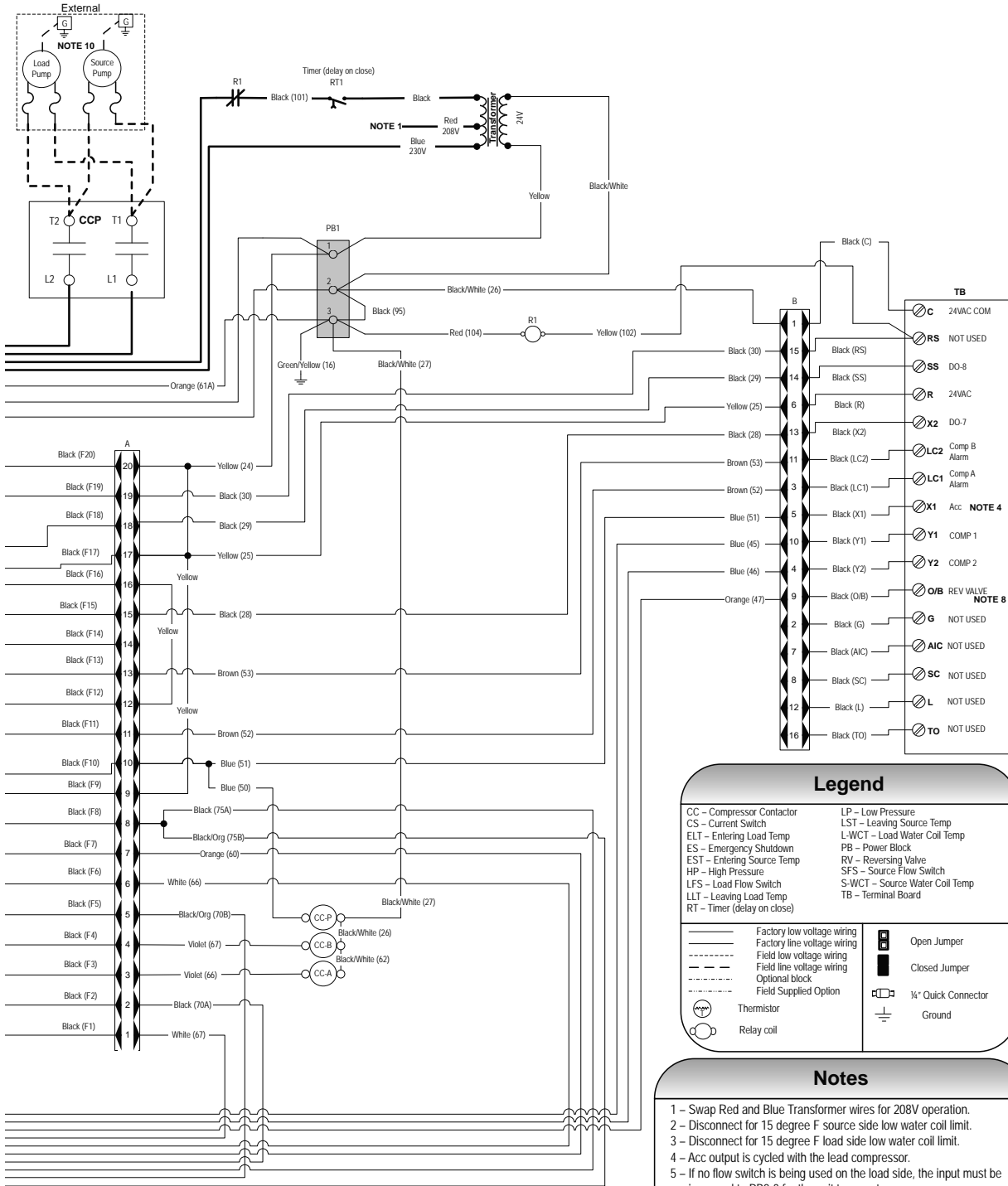

Legend

CC - Compressor Contactor	LP - Low Pressure
CS - Current Switch	LST - Leaving Source Temp
ELT - Entering Load Temp	L-WCT - Leaving Source Coil Temp
ES - Emergency Shutdown	PB - Power Block
EST - Entering Source Temp	RV - Reversing Valve
HP - High Pressure	SFS - Source Flow Switch
LFS - Load Flow Switch	S-WCT - Source Water Coil Temp
LLT - Leaving Load Temp	TB - Terminal Board
RT - Timer (delay on close)	

Factory low voltage wiring	Open Jumper
Factory line voltage wiring	Closed Jumper
Field low voltage wiring	1/4" Quick Connector
Field line voltage wiring	Ground
Optional block	
Field Supplied Option	
Thermistor	
Relay coil	

- ### Notes
- 1 - Swap Red and Blue Transformer wires for 208V operation.
 - 2 - Disconnect for 15 degree F source side low water coil limit.
 - 3 - Disconnect for 15 degree F load side low water coil limit.
 - 4 - Acc output is cycled with the lead compressor.
 - 5 - If no flow switch is being used on the load side, the input must be jumpered to PB2-3 for the unit to operate.
 - 6 - If no flow switch is being used on the source side, the input must be jumpered to R on PB1-1 for the unit to operate.
 - 7 - Jumpers must be set as shown for correct control operation. If a communication card is present, it must be removed to verify jumper settings.
 - 8 - The reversing valve will be energized for cooling mode.
 - 9 - Used for Emergency Shutdown in conjunction with a normally open relay.
 - 10 - External load and source pumps must be externally fused.

Wiring Schematics cont.

MUI Wiring Diagram

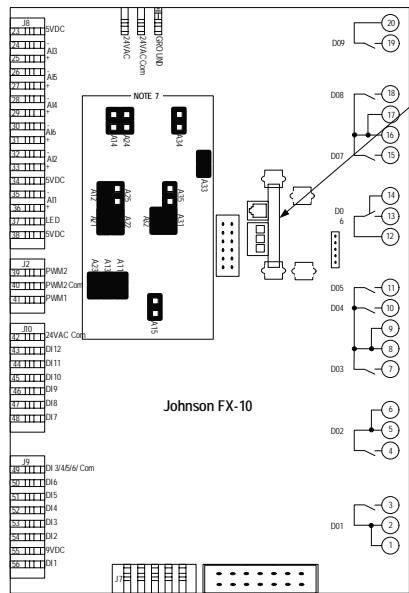

DLI Card

Instructions :

- 1.) Disconnect all power sources to the unit
- 2.) Remove MUI from Back Plate
- 3.) Follow Wiring Instruction Below
- 4.) Reinstall MUI to Back Plate

MUI Back Plate

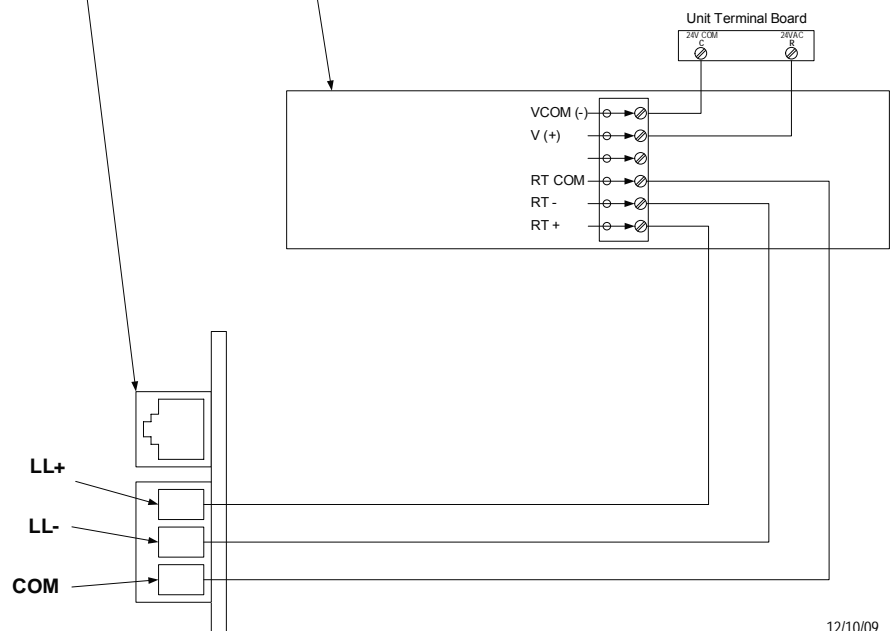

12/10/09

Field Wiring and Control Setup

Figure 2 - High Voltage Connections

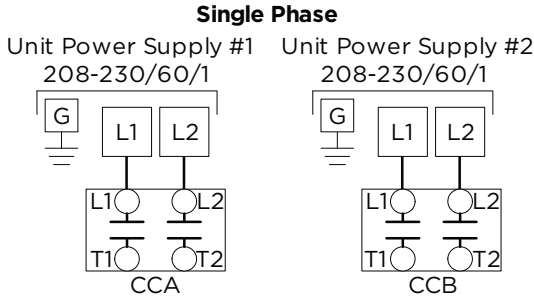
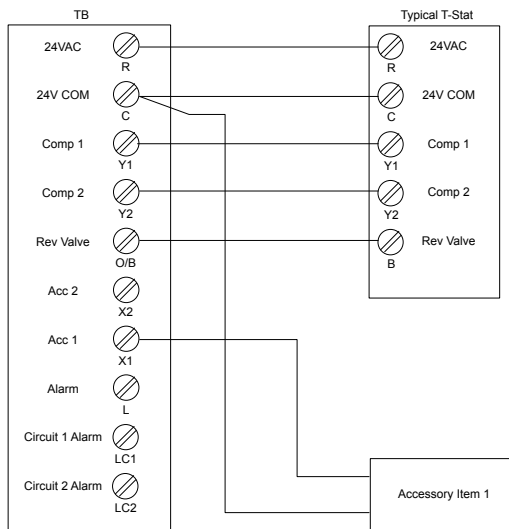
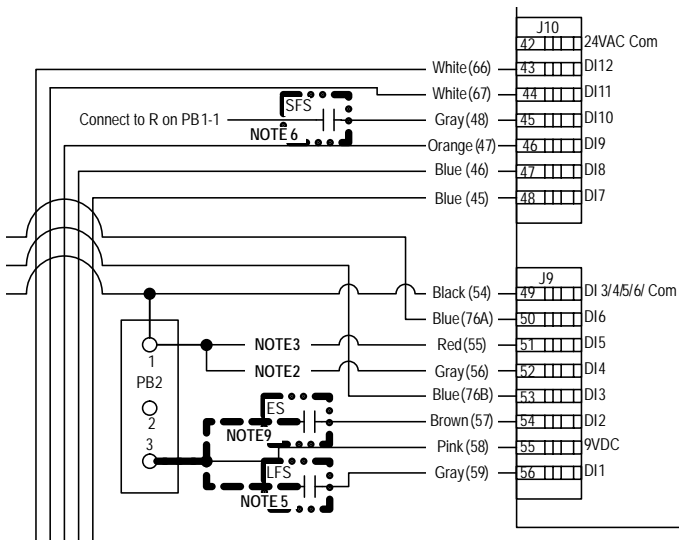

Figure 3 - Low Voltage Connections



NOTES:
 1) Acc Output 1 is cycled with the lead compressor
 2) Acc Output 2 is cycled with the lag compressor

Figure 4 - Wiring Schematic



Line Voltage

High Voltage Connections

Connect power wiring as shown in Figure 2.

208 Volt Operation

Switch red and blue transformer wires for 208V operation.

Low Voltage Operation

Thermostat/Controller (Aquistat)

A two-stage 24 VAC thermostat or liquid controller (field supplied) must be used to turn the unit on or off, and to switch it from cooling to heating if necessary. Multiple units in the same bank must be controlled from one thermostat/controller (must be isolation relays for multiple unit applications).

Low Voltage Connections

Connect low voltage thermostat wiring as shown in Figure 3. Connections shown are for typical thermostat. Actual connections may vary with specific device used.

NOTE: If a separate transformer is used to supply a Y1, Y2, or B signal to the unit controls, isolation relays must be used.



CAUTION: Use only copper conductors for field installed wiring. Terminals in the unit are not designed for other types of conductors.



WARNING: All wiring must comply with local and state codes. Disconnect the power supply before beginning to wire to prevent electrical shock or equipment damage.

NOTE: Accessory output is selectable as normally open or normally closed using the unit display. Normally closed is the factory default setting.

Source Flow Switch (SFS)

Unit is factory shipped with jumpers on the Source Flow Switch pins J10-45 (entering). Flow proving switch is optional, hook up as shown in Fig. 4 and Note 6. The unit will not operate without a flow proving switch or jumper installed.

Load Flow Switch (LFS)

Unit is factory shipped with jumpers on the Load Flow Switch pins J9-56 (leaving). Flow proving switch is optional, hook up as shown in Fig. 4 and Note 5. The unit will not operate without a flow proving switch or jumper installed.

Load and Source Pump

The load or source pump connection allows for 4.2 A at 208/60/1 on each. This pump supply should be adequate for most applications. Please consult the electrical schematic and table for more detail.

Field Wiring and Control Setup cont.

Accessory Relay Setup

The accessory output set to “close” upon Y1 compressor call (compressor is delayed 90 sec. after Y1) but can be set to “open” with Y1.

To change ACC1:

- Using up and down keys, scroll to “Acc 1 Sel” hit “ENTER” and “ON Comp” begins flashing
- Using up and down keys, select “ON Comp” for activation with Y1 Call or “OFF Comp” for deactivation with Y1

Lead/Lag Selection

Compressor Lead/Lag Selection is factory set to “ON” but can be set to “OFF”.

To change Lead/Lag On/Off:

- Using up and down keys, scroll to “LEAD/LAG SELECT” hit “ENTER” and “OFF” begins flashing
- Using up and down keys, select “ON” for activation or “OFF” for deactivation

°F or °C - Unit of Measure

Degrees Fahrenheit is factory set, however degrees Celsius can be selected using the following procedure:

To Change Unit of Measure:

- On FX10 control using up and down keys, scroll to “SETTINGS”
- Using up and down keys, scroll to “UNIT OF MEASURE” hit “ENTER” and “UNIT OF MEASURE” begins flashing
- Using up and down keys, select “F” for degrees Fahrenheit or “C” for degrees Celsius

Other Field Options

Other field selectable options are available as shown in the maintenance menu on page 24 of the FX10 control using a similar procedure as shown in the above examples. These would include thermostat enabling, and emergency shutdown.

Control Features

Anti Short Cycle

High Pressure Protection

Low Pressure Protection

Advanced Freeze Detection Setpoint

Random Start

Display for diagnostics

Reset Lockout at disconnect

Intelligent reset for field installed flow switches

1 Accessory output

Compressor Lead/Lag

Compressor Current Switches

Field Selectable Options

Freeze Detection Sensing Select (DI-4 and DI-5)

The freeze detection temperature sensing selection inputs allow the user to adjust the setpoints. The source sensors are wired to inputs AI-3 and AI-4 while the load sensors are wired to inputs AI-5 and AI-6. The setpoints for both, the load and source, are factory set for 30°F. In order to change the setpoint to 15°F on the source, remove the jumper wire from DI-4 (wire #56). The load setpoint can be changed by removing the jumper wire from DI-5 (wire #55).

Accessory Output (DO-4)

The accessory output will be energized 90 seconds prior to the lead compressor output being energized. When the lead compressor output is turned off the accessory output will be deactivated immediately. The output is selectable for normally open or normally closed operation through the unit mounted user interface or from a building automation system.

Control and Safety Features

Emergency Shutdown

The emergency shutdown mode can be activated by a command from a facility management system or a closed contact on DI-2. The default state for the emergency

shutdown data point is off. When the emergency shutdown mode is activated, all outputs will be turned off immediately and will remain off until the emergency shutdown mode is deactivated. The first time the compressor starts after the emergency shutdown mode has been deactivated, there will be a random start delay present.

Lockout Mode

Lockout mode can be activated by any of the following fault signals: refrigerant system high pressure, refrigerant system low pressure, heating freeze detection, cooling freeze detection, and compressor current sensor. When any valid fault signal remains continuously active for the length of its recognition delay, the controller will go into fault retry mode, which will turn off the compressor. After the Compressor short cycle delay, the compressor will attempt to operate once again. If three consecutive faults are recognized during a single heating or cooling demand, the unit will go into lockout mode, turning off the compressor and enabling the alarm output until the controller is reset. The fault count will automatically reset when the heating or cooling command becomes satisfied. If a fault occurs on a dual compressor unit, the other compressor will continue to operate based on the heating or cooling demand. The lockout condition can be reset by powering down the controller by holding both the enter and escape keys on the optional user interface.

Advanced Freeze Detection System

The source and load heat exchangers are protected by a multi-sourced temperature logic strategy. The temperature logic is based upon the refrigerant temperature sensed as the refrigerant is about to enter the heat exchanger; while entering and leaving water temperatures are being used as correlating factors. The detection scheme is shown as basic and advanced algorithms.

Control Features cont.

Basic Freeze Detection Operation: “Comp1 or Comp2 Freeze” Alarm

This alarm can be triggered by one of two detection schemes.

Hard Limit Freeze Detection

If the refrigerant temperature drops below the freeze detection setpoint by 1.8°F, the associated compressor is locked out immediately regardless of any other factors and requires a manual reset. **NOTE: This Lockout produces a “Comp 1 or Comp 2 Freeze” error on the MUI display.**

Freeze Detection

The refrigerant temperature is compared to the freeze detection setpoint (15°F [antifreeze] or 33°F [water] field selectable), and if the temperature falls below the setpoint for 30 continuous seconds, the associated compressor will be halted. This function becomes enabled after the first two minutes of compressor operation. Three such events in 60 minutes will trigger a compressor lockout that requires a manual reset. **NOTE: This Lockout produces a “Comp 1 or Comp 2 Freeze” error on the MUI display.**

In addition to the above:

Entering Water Temperature Influence

If the entering water temperature of the evaporative heat exchanger is within 10°F of the freeze setpoint, the previously mentioned two minute delay will be eliminated. This allows the freeze detection to operate immediately when the compressor starts based on entering water temperature.

Leaving Water Temperature Influence

If the leaving water temperature of the evaporative heat exchanger is within 10°F of the freeze setpoint, the previously mentioned 30 second delay will begin to be proportionately reduced, ending at a 1 second delay when the leaving water temperature is 1.5°F above the freeze setpoint.

Dual Circuited Heat Exchanger Protection

A low temperature condition on either refrigerant circuit will prevent the start of both compressors. If the low temperature condition exists for 5 minutes when both compressors are off, a lockout is triggered for both compressors. However, if –for instance–both compressors are operating and circuit 1 experiences a refrigerant temperature below the freeze detection setpoint such that compressor 1 is halted, compressor 2 will not be halted as a result.

Advanced Freeze Detection Operation: “Pre Freeze” Alarm

Predictive freeze condition detection:

If the refrigerant temperature is within 7.2°F of the freeze detection setpoint, the predictive freeze detection algorithm is enabled, and if the logic determines that a freeze condition is likely to happen based on current conditions, the compressor of the involved refrigerant circuit is immediately stopped. Three (3) such events in 60 minutes will trigger a compressor lockout that requires a manual reset. In the absence of such a

condition, the compressor is allowed to operate so that the refrigerant temperature may eventually be at the threshold of the freeze detection setpoint. **NOTE: This Lockout produces a “Pre Freeze” detection error on the MUI display.**

Capacity Limiting

If the leaving water temperature drops to 1.8°F above the freeze detection setpoint, the lead compressor is halted. When the leaving water temperature rises to 3.6°F above the freeze detection setpoint, it will be allowed to resume operation. This limiting is allowed to repeat indefinitely. This causes “COMP1 Low Limit” to be displayed on the MUI.

If the leaving water temperature drops to the freeze detection setpoint, the lag compressor is halted. When the leaving water temperature rises to 1.8°F above the freeze detection setpoint, it will be allowed to resume operation. This limiting is allowed to repeat indefinitely. This causes “COMP2 Low Limit” to be displayed on the MUI.

Compressor Current Switch (AI-3 EXP and AI-4 EXP)

The compressor current switch is designed to insure that the compressor is on when the compressor output is energized. This switch is normally open and closes when current is flowing to the compressor. If the compressor fails to start the switch will open. The switch must be open for a continuous 5 seconds for a fault to occur. After 3 faults in 60 minutes the control will put the unit into an alarm state.

Optional Flow Proving Switch (DI-1 and DI-10)

The load and source flow-proving switches are optional and can be field installed. These switches shall be normally open flow switches that will close when the water flow through the heat exchangers reach an acceptable level. The flow-proving switches must be closed 15 seconds prior to enabling either compressor output (DO-1 and DO-2). If the load flow-proving switch opens at any time both compressor outputs (DO-1 and DO-2) must be disabled immediately.

High Pressure (DI-11 and DI-12)

The high-pressure switches shall be a normally closed (NC) switch that monitors the systems compressor discharge refrigerant pressures. There shall be an individual high pressure switch for each circuit. If the input senses the high-pressure switch is open during the period that the compressor output is enabled, it must shut down the compressor immediately and count the fault. The compressor minimum on time does not apply if the high-pressure switch trips. The compressor will not restart until the short cycle time delay has been satisfied. If the high-pressure fault occurs in one circuit the other compressor will continue to operate based on the heating or cooling demand.

Low Pressure (DI-3 and DI-6)

The low-pressure switches shall be a normally closed (NC) switch that monitors the systems compressor suction line refrigerant pressure. The input shall be checked 15 seconds before compressor start up to insure the pressure switch is closed and then ignored for the first 2 minutes after the compressor output (DO-1 or DO-2) is enabled. If the switch

Control Features cont.

is open continuously for (30) seconds the compressor output for that circuit will be disabled. The compressor will not restart until the short cycle time delay has been satisfied. If a low-pressure fault occurs in one circuit the other compressor will continue to operate based on the heating or cooling demand.

Compressor 1 Alarm Output (DO-5)

The compressor 1 alarm output will be enabled when stage 1 is in the lockout mode and will be disabled when the lockout is reset.

Compressor 2 Alarm Output (DO-6)

The compressor 2 alarm output will be enabled when stage 2 is in the lockout mode and will be disabled when the lockout is reset.

Test Mode

The unit controls system can be put into test mode to eliminate startup delays to aid in trouble shooting. To put the unit into test mode hold the “ESC” and “Down Arrow” keys until LED 8 begins to flash. The control will remain in test mode until power is cycled or after 30 minutes.

Sequence of Operation

Power Fail Restart

When the controller is first powered up, the outputs will be disabled for a random start delay time (See Random Start Delay). The delay is provided to prevent simultaneous starting of multiple heat pumps. Once the timer expires, the controller will operate in the occupied mode until it is commanded to another mode by a remote thermostat. A restart status variable is available for indication of this occurrence.

Random Start Delay

This delay will be used after every power failure, as well as the first time the compressor(s) is started after the control exits the emergency shutdown mode. The default time period for the start delay will be random between 1 and 120 seconds.

Compressor Fixed On Delay Time

The Compressor Fixed On Delay Time will ensure that the compressor output is not enabled for (90) seconds after the control receives a call to start the compressor.

Compressor Minimum On Delay

The compressor minimum on delay will ensure that the compressor output(s) are enabled for a minimum of (2) minute each time the compressor output is enabled. This will apply in every instance except in the event the high-pressure switch is tripped or emergency shutdown, then the compressor output will be disabled immediately.

Compressor Short Cycle Delay Time

The compressor short cycle time delay will ensure that the compressor output will not be enabled for a minimum of five (5) minutes after it is disabled. This allows for the system refrigerant pressures to equalize after the compressor is disabled.

Compressor Lead/Lag

Compressor lead/lag is a standard part of the FX10 control system. The unit is shipped from the factory with lead/lag enabled. Lead/lag can be deactivated through the unit mounted user interface. Lead/lag will always start the compressor with the least amount of run time and stop the compressor with the longest run time.

Heating Cycle

During the heating cycle, the reversing valves will be positioned for heating operation. The thermostat or aquastat will command the reversing valves “Off” for heating. If the compressor short cycle time delay has been satisfied, the lead compressor will turn on after the accessory output has been enabled, the low pressure switches have been verified, and the fixed compressor start delay timer has been satisfied. When heating is no longer required, the compressor will be turned off immediately after the compressor minimum on delay has been satisfied. After the compressor output is turned off, it will remain off for the time specified in the compressor short cycle time delay. If the first stage compressor is not able to satisfy the heating demand, the second stage compressor will be activated by the thermostat or aquastat. The controller is allowed to operate the heat pump in the heating mode regardless of the outdoor air temperature.

Cooling Cycle

During the cooling cycle, the reversing valves will be positioned for cooling operation. The thermostat or aquastat will command the reversing valves “On” for cooling. If the compressor short cycle time delay has been satisfied, the lead compressor will turn on after the accessory output has been enabled, the low pressure switches have been verified, and the fixed compressor start delay timer has been satisfied. When cooling is no longer required, the compressor will be turned off immediately after the compressor minimum on delay has been satisfied. After the compressor output is turned off, it will remain off for the time specified in the compressor short cycle time delay. If the first stage compressor is not able to satisfy the cooling demand, the second stage compressor will be activated by the thermostat or aquastat. The controller is allowed to operate the heat pump in the cooling mode regardless of the outdoor air temperature.

Inputs and Outputs Configuration

DUAL STAGE WW			
Input Name	Input	Output Name	Output
Entering Load Water Temperature	AI 1	Compressor 1	DO1
Leaving Load Water Temperature 1	AI 2	Compressor 2	DO2
Source Heating Freeze Detection 1	AI 3	Reversing Valve	DO3
Source Heating Freeze Detection 2	AI 4	Accessory	DO4
Load Cooling Freeze Detection 1	AI 5	Compressor 1 Alarm	DO5
Load Cooling Freeze Detection 2	AI 6	Compressor 2 Alarm	DO6
		Network Output	DO7
Load Flow Proving Switch	DI 1	Network Output	DO8
Emergency Shutdown	DI 2	Network Output	DO9
Stage 2 Low Pressure	DI 3		
Source Htg Freeze Detection Select - 30°F	DI 4	Future	PWM1
Load Htg Freeze Detection Select - 30°F	DI 5	Future	PWM2
Stage 1 Low Pressure	DI 6		
Thermostat Y1	DI 7		
Thermostat Y2	DI 8		
Thermostat B	DI 9		
Source Flow Proving Switch	D10		
Stage 1 High Pressure	DI11		
Stage 2 High Pressure	DI12		
XP10 Expansion Card			
Input Name	Input	Output Name	Output
Entering Source Water Temperature	AI 1	Unused	DO 1
Leaving Source Water Temperature 1	AI 2	Unused	DO 2
Current Switch 1 - Compressor 1	AI 3	Unused	DO 3
Current Switch 2 - Compressor 2	AI 4	Unused	DO 4

Unit Display and Interface

The Unit Display allows the user to view entering and leaving water temperatures, freeze detection readings, inputs and outputs, and allows the user enable and disable certain control functions through the various menus. The interface also displays all faults on the LCD once the unit has locked out to aid in diagnostics.

There are 10 LED indicator lights that indicate the following:

- Power - Shows that the FX processor is operational
- ⚠ Alarm - Lights when there is a lock-out or faulty freeze detection sensor
- 1 - Flashing shows Compressor 1 is running
- 2 - Flashing shows Compressor 2 is running
- 3 - On shows Compressor 2 is lead
- 4 - On shows Reversing valve in cool
- 8 - On shows unit in 'Test' mode

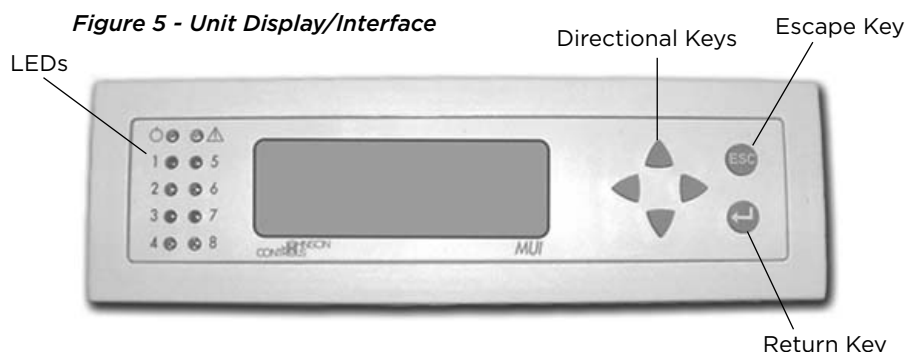

Unit Display and Interface cont.

MUI Menu Navigation

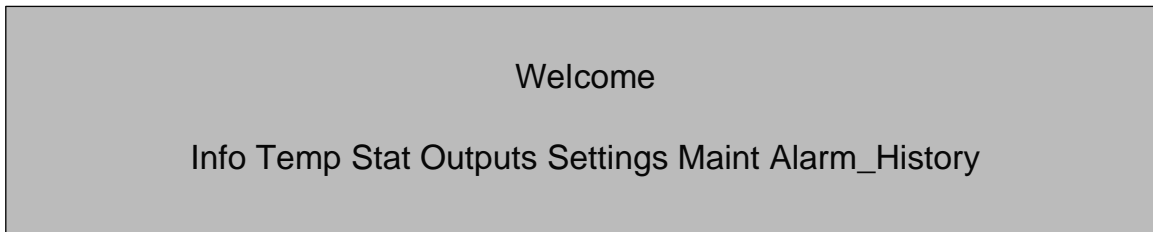

Info

Dual Stage
Water-to-Water
PRODCWWE-08B
MM/DD/YY

Temp

Temperatures

Enter Load	77.2°F
Leave Load	51.0°F
Enter Source	70.0°F
Leave Source	66.0°F
Source Frz1	77.8°F
Source Frz2	30.0°F
Load Frz1	30.0°F
Load Frz2	30.0°F
Src Frz Setpt	30.0°F
LD Frz Setpt	30.0°F

Stat

Status

Unit Status	Auto
Y1 Status	OFF
Y2 Status	OFF
O Status	OFF
Emerg Shutdown	OFF
Current Sens1	OFF
Current Sens2	OFF
Load Flow	OFF
Src Flow	OFF
Low Pres1	ON
Hi Pres1	OFF
Low Pres2	ON
Hi Pres2	ON
Comp1 Low Limit	NML
Comp2 Low Limit	NML

Outputs

Outputs

Comp1 Status	ON
Comp2 Status	OFF
Acc1 Status	OFF
Stg1 Status	Normal
Stg2 Status	Normal
BO7	OFF
BO8	OFF
BO9	OFF
EXPB01	OFF
EXPB02	OFF
EXPB07	OFF
EXPB08	OFF

Settings

Settings

Unit of Measure	F
-----------------	---

Maint

Maintenance

Y1 Input	Auto
Y2 Input	Auto
O Input	Auto
Emerg SD	Auto
Acc1 Sel	ON Comp
Lead/Lag Select	OFF
Low Frz Setpt	15°F
Hi Frz Setpt	33°F
Acc1 Dly	9 S

Alarm

ALARM SUMMARY

~/High Pressure

Alarm lock-outs are reset by cycling power, by pressing the “ESC” and Return  keys simultaneously for a minimum of 15 seconds.

Test mode is enabled by holding the ‘Esc’ and Down Arrow simultaneously for a minimum of 15 seconds and releasing. Test mode times out after 30 minutes, and may also be ended by pressing ‘ESC’ and Up Arrow simultaneously and releasing. Test Mode bypasses the On Delay (90 sec) and Random Start timers for quicker troubleshooting. It also allows cycling the reversing valve without compressor shutdown.

Unit Display and Interface cont.

Menu and Menu Contents

Alarm

- Displays unit alarms until the unit has been reset (Unit alarms can be reset by holding both the Escape (ESC) key and Return (←) key for five seconds or by power cycling the unit.)

Alarm History

If a fault occurs the fault will be recorded in history viewable on the unit mounted display. Each fault type will be displayed in the history menu with a number between 0 and 3. A reading of 3+ means that the fault has occurred more than 3 times in the past. The history menu can be cleared with a power cycle only. Alarm date and time are not included in the history.

Unit Alarms

Unit alarms are shown on the display once the unit has locked out.

Load Flow - Load Flow Switch is Not Closed

- The load flow switch must be closed prior to either compressor starting and must remain closed for the entire run time of the compressor(s).

Low Pressure 1 - Compressor Circuit 1 Low Pressure Switch

- The low pressure switch is checked before compressor start up and is monitored during compressor operation.

Src FP 1 Temp Low - Source Freeze Detection Sensor 1

- The source freeze detection sensor on compressor circuit 1 has reached its setpoint.

Src FP 1 Sensor Bad

- The sensor for source freeze detection on compressor circuit 1 is unreliable or is not reading.

LD FP 1 Temp Low - Load Freeze Detection Sensor 1

- The load freeze detection sensor on compressor circuit 1 has reached its setpoint.

LD FP 1 Sensor Bad

- The sensor for load freeze detection on compressor circuit 1 is unreliable or is not reading.

Source Flow - Source Flow Switch is Not Closed

- The source flow switch must be closed prior to either compressor starting and must remain closed for the entire run-time of the compressor(s).

High Pressure 1 - Compressor Circuit 1 High Pressure Switch

- If high pressure switch 1 opens at any time during compressor 1 run time the compressor will be shut down immediately.

Low Pressure 2 - Compressor Circuit 2 Low Pressure Switch

- The low pressure switch is checked before compressor start up and is monitored during compressor operation.

Src FP 2 Temp Low - Source Freeze Detection Sensor 2

- The source freeze detection sensor on compressor circuit 2 has reached its setpoint.

Src FP 2 Sensor Bad

- The sensor for source freeze detection on compressor circuit 2 is unreliable or is not reading.

LD FP 2 Temp Low - Load Freeze Detection Sensor 2

- The load freeze detection sensor on compressor circuit 2 has reached its setpoint.

LD FP 2 Sensor Bad

- The sensor for load freeze detection on compressor circuit 2 is unreliable or is not reading.

High Pressure 2 - Compressor Circuit 2 High Pressure Switch

- If high pressure switch 2 opens at any time during compressor 2 run time the compressor will be shut down immediately.

Comp Start Failure - Compressor Start Failure

- If either compressor fails to start when the contactor pulls in the compressor current switch will cause that compressor to be locked out after 2 retries. The other compressor will continue to operate normally in this condition.

Reference Calculations

Heating Calculations: $\text{LWT} = \text{EWT} - \frac{\text{HE}}{\text{gpm} \times 500^*}$	Cooling Calculations: $\text{LWT} = \text{EWT} + \frac{\text{HR}}{\text{gpm} \times 500^*}$
--	--

NOTE: * When using water. Use 485 for 15% methanol/water or Environol solution.

Legend

ABBREVIATIONS AND DEFINITIONS:

COP = coefficient of performance (HC/kW x 3.413)	Lgpm = load flow in gallons per minute
EER = cooling energy efficiency (TC/kW)	LLT = leaving load fluid temperature from heat pump
ELT = entering load fluid temperature to heat pump	LST = leaving source fluid temperature from heat pump
EST = entering source fluid temperature to heat pump	LWPD = load heat exchanger water pressure drop
ft HD = pressure drop in feet of head	psi = pressure drop in pounds per square inch
HC = heating capacity in MBtu/h	Sgpm = source flow in gallons per minute
HE = total heat of extraction, MBtu/h	SWPD = source heat exchanger water pressure drop
HR = total heat of rejection, MBtu/h	TC = total cooling capacity in MBtu/h
kW = total power unit input, kilowatts	

Unit Startup

Verify the following:

- High voltage is correct and matches nameplate
- Fuses, breakers and wire size are correct
- Low voltage wiring is complete
- Piping is complete and the water system has been cleaned and flushed
- Air is purged from closed loop system
- Isolation valves are open and water control valves or loop pumps are wired
- Service/access panels are in place
- Transformer has been switched to lower voltage tap if needed (208/230 volt units only)
- Unit controls are in "off" position
- Flow switches are installed and ready
- Freeze detection setpoints have been set in the microprocessor



WARNING: Verify ALL water controls are open and allow water flow PRIOR to engaging the compressor. Failure to do so can result in freezing the heat exchanger or water lines causing permanent damage to the unit.

Startup Steps

- Set thermostat control above cooling setpoint.
- Set thermostat control in cooling mode.
- Slowly reduce the control setting until both the compressor and water control valve/loop pumps are activated. Verify that the compressor is on and that the water flow rate is correct by measuring pressure drop through the heat exchanger and comparing to the Pressure Drop table. Check for correct rotation of scroll compressors. Switch any two power leads at the L1, L2, and L3 line voltage termination block if incorrect.
- Perform a cooling capacity test by multiplying gpm x ΔT x 485 (antifreeze/water). Use 500 for 100% water. Check capacity against catalog data at same conditions.
- Set control to "OFF" position.
- Leave unit "OFF" for approximately five (5) minutes to allow pressure to equalize.
- Adjust control below heating setpoint.
- Set control in "HEAT" position mode.
- Slowly increase the control setting until both compressor and water control valve/loop pumps are activated. The reversing valve should be heard changing over.
- Perform a heating capacity test by multiplying gpm x ΔT x 485 (antifreeze/water). Use 500 for 100% water. Check capacity against catalog data at same conditions.
- Check for vibrations, noise and water leaks.
- Set system to maintain desired setpoint.
- Instruct the owner/operator of correct control and system operation.

Operating Parameters

Heating Mode

Entering Load Temp (°F)	Entering Source Temp (°F)	Suction Pressure (psig)	Discharge Pressure (psig)	Superheat (°F)	Subcooling (°F)
60	30	10-20	60-75	8-10	6-10
	50	20-30	65-80	9-11	8-12
	70	30-40	70-85	10-14	10-14
	90	40-50	75-90	22-27	13-17
80	30	10-20	100-115	9-11	8-12
	50	20-30	107-122	10-12	11-15
	70	30-40	115-130	10-14	12-16
	90	40-50	120-135	12-18	13-17
100	30	10-20	140-155	9-11	9-13
	50	20-30	148-163	9-11	11-15
	70	35-50	155-170	8-12	12-16
	90	45-70	160-180	7-13	13-17
120	30	10-20	180-195	9-12	9-13
	50	20-35	185-205	9-12	11-15
	70	30-50	195-215	8-12	13-17
	90	50-75	205-225	8-14	14-18
140	30	10-25	218-238	10-12	9-13
	50	15-35	225-250	9-11	11-15
	70	30-50	235-262	7-11	13-17
	90	55-80	245-275	6-12	14-18

NOTE: Operating data based on normal conditions with 25 gpm for the load and source.

2/14/12

Cooling Mode

Entering Load Temp (°F)	Entering Source Temp (°F)	Suction Pressure (psig)	Discharge Pressure (psig)	Superheat (°F)	Subcooling (°F)
50	30	15-25	28-50	18-26	9-13
	50	20-35	50-70	10-14	9-13
	70	20-35	86-106	7-11	10-14
	90	20-40	125-145	6-10	11-15
	110	20-40	155-185	5-9	15-19
70	30	15-25	28-50	25-35	9-13
	50	25-35	50-70	17-23	9-13
	70	30-40	90-110	10-14	11-15
	90	35-50	130-150	9-13	12-18
	110	35-55	165-195	8-12	16-22
90	30	10-35	28-50	30-50	10-14
	50	25-40	50-75	20-35	10-14
	70	35-50	90-120	10-25	11-16
	90	45-60	130-160	10-18	14-20
	110	50-70	175-205	10-16	17-23
110	30	15-35	30-50	50-70	10-14
	50	30-45	55-75	40-65	10-14
	70	40-60	95-125	25-50	12-19
	90	50-80	140-170	15-40	16-23
	110	65-90	180-220	10-25	20-26

NOTE: Operating data based on normal conditions with 25 gpm for the load and source.

2/14/12

Load and Source Pressure Drop

Model	gpm	Pressure Drop (psi)				
		30°F	50°F	70°F	90°F	110°F
084	15	1.6	1.5	1.4	1.2	1.2
	20	2.5	2.4	2.2	1.9	1.9
	25	3.4	3.2	3.1	2.6	2.6

2/14/12

Thermistor Resistance

Thermistor Temperature		Resistance in Ohms
°F	°C	
5	-15	758
14	-10	789
23	-5	822
32	0	855
41	5	889
50	10	924
59	15	960
68	20	997
77	25	1035
86	30	1074
95	35	1113
104	40	1153
113	45	1195
122	50	1237
131	55	1279
140	60	1323
149	65	1368
158	70	1413
167	75	1459
176	80	1506
185	85	1554
194	90	1602
203	95	1652
212	100	1702

2/14/12

Compressor Resistance

Model	Start Winding	Run Winding
084	1.33 ohms	0.38 ohms

NOTE: Tolerance = +/- 7%

2/14/12

Heat of Extraction/Rejection Data

Model	Source gpm	Load gpm	EST °F	Heat Of Extraction (HE)					Heat of Rejection (HR)				
				60°F	80°F	100°F	120°F	140°F	30°F	50°F	70°F	90°F	110°F
084	20	20	30	56.8	50.4	44.1	38.4	32.4	n/a	92.7	96.0	97.1	96.4
			50	80.4	74.3	68.1	62.4	56.5	n/a	100.3	110.3	120.2	130.2
			70	104.1	98.1	92.2	86.5	80.7	n/a	103.3	122.0	140.7	159.4
			90	127.7	122.0	116.3	110.6	n/a	n/a	90.8	115.1	139.4	n/a
			110	n/a	n/a	n/a	n/a	n/a	n/a	89.2	120.1	n/a	n/a

NOTES: All values assume water. With antifreeze solutions, be sure to apply the appropriate correction factor.
Capacities based on 20 gpm load and source.

2/14/12

Heating Cycle Analysis

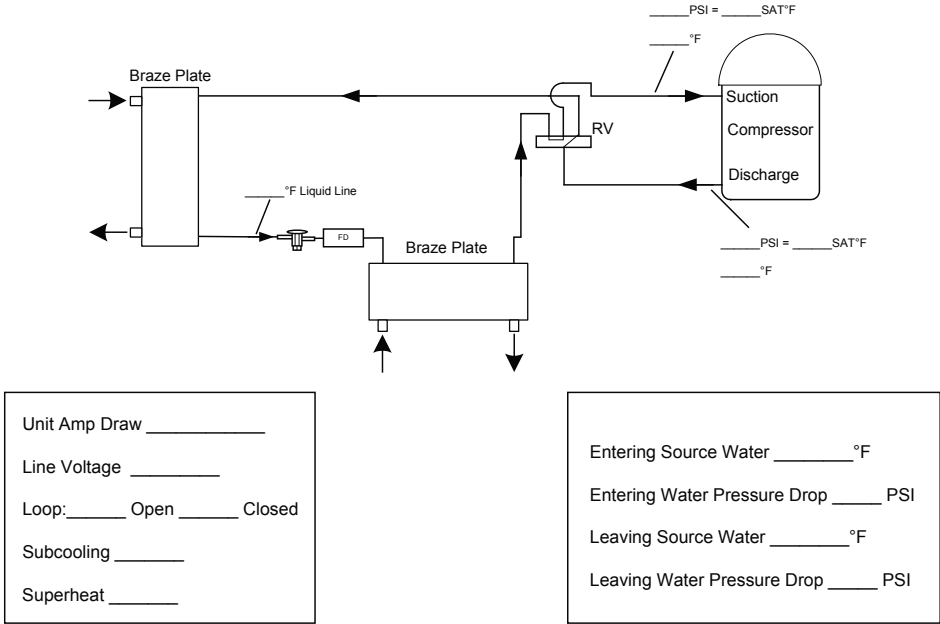

NOTE: Do not attach refrigerant gauges unless a problem is suspected!

Cooling Cycle Analysis

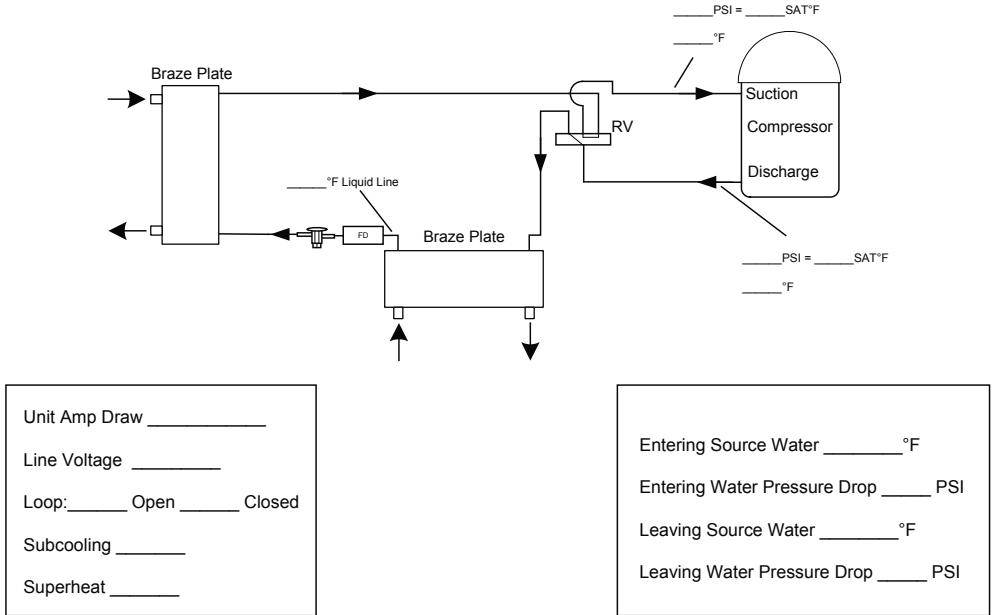

NOTE: Do not attach refrigerant gauges unless a problem is suspected!

Startup and Troubleshooting Form

Company Name: _____ Company Phone No: _____
 Technician Name: _____ Date: _____
 Model No: _____ Serial No: _____
 Owner's Name: _____ Open or Closed Loop: _____
 Installation Address: _____ Installation Date: _____

Check One

Start up/Check-out for new installation Troubleshooting Problem: _____

1. FLOW RATE IN GPM (SOURCE SIDE HEAT EXCHANGER)

Water In Pressure: a. _____ PSI
 Water Out Pressure: b. _____ PSI
 Pressure Drop = a - b c. _____ PSI
 Convert Pressure Drop to Flow Rate
 (refer to *Pressure Drop* table) d. _____ GPM

2. TEMPERATURE RISE OR DROP ACROSS SOURCE SIDE HEAT EXCHANGER

	COOLING	HEATING
Water In Temperature:	e. _____ °F	e. _____ °F
Water Out Temperature:	f. _____ °F	f. _____ °F
Temperature Difference:	g. _____ °F	g. _____ °F

3. TEMPERATURE RISE OR DROP ACROSS LOAD SIDE HEAT EXCHANGER

	COOLING	HEATING
Water In Temperature:	h. _____ °F	h. _____ °F
Water Out Temperature:	i. _____ °F	i. _____ °F
Temperature Difference:	j. _____ °F	j. _____ °F

4. HEAT OF REJECTION (HR) / HEAT OF EXTRACTION (HE) CALCULATION

HR or HE = Flow Rate x Temperature Difference x Brine Factor*
 d. (above) x g. (above) x 485 for Methanol or Environol, 500 for water*
 Heat of Extraction (Heating Mode) = _____ btu/hr
 Heat of Rejection (Cooling Mode) = _____ btu/hr
 Compare results to Capacity Data Tables

Note: Steps 5 through 8 need only be completed if a problem is suspected

5. WATTS

	COOLING	HEATING	HYDRONIC
Volts:	m. _____ VOLTS	m. _____ VOLTS	m. _____ VOLTS
Total Amps (Comp. + Fan):	n. _____ AMPS	n. _____ AMPS	n. _____ AMPS
Watts = m. x n. x 0.85	o. _____ WATTS	o. _____ WATTS	o. _____ WATTS

6. CAPACITY

Cooling Capacity = HR. - (o. x 3.413) p. _____ btu/hr
 Heating Capacity= HE. + (o. x 3.413) p. _____ btu/hr

7. EFFICIENCY

Cooling EER = p. / o. q. _____ EER
 Heating COP = p. / (o. x 3.413) q. _____ COP

8. SUPERHEAT (S.H.) / SUBCOOLING (S.C.)

	COOLING	HEATING	HYDRONIC
Suction Pressure:	r. _____ PSI	r. _____ PSI	r. _____ PSI
Suction Saturation Temperature:	s. _____ °F	s. _____ °F	s. _____ °F
Suction Line Temperature:	t. _____ °F	t. _____ °F	t. _____ °F
Superheat = t. - s.	u. _____ °F	u. _____ °F	u. _____ °F
Head Pressure:	v. _____ PSI	v. _____ PSI	v. _____ PSI
High Pressure Saturation Temp.:	w. _____ °F	w. _____ °F	w. _____ °F
Liquid Line Temperature*:	x. _____ °F	x. _____ °F	x. _____ °F
Subcooling = w. - x.	y. _____ °F	y. _____ °F	y. _____ °F

* Note: Liquid line is between the source heat exchanger and the expansion valve in the cooling mode; between the load heat exchanger and the expansion valve in the heating mode.

Troubleshooting

Should a major problem develop, refer to the following information for possible causes and corrective steps.

If compressor won't run:

1. The fuse may be open or the circuit breaker is tripped. Check electrical circuits and motor windings for shorts or grounds. Investigate for possible overloading. Replace fuse or reset circuit breakers after fault is corrected.
2. Supply voltage may be too low. Check it with a volt meter.
3. Control system may be faulty. Check control for correct wiring of thermostat or aquastat and check the 24 volt transformer for proper voltage.
4. Wires may be loose or broken. Replace or tighten.
5. The low pressure switch may have tripped due to one or more of the following:
 - a) Heating
 - 1) Plugged heat exchanger on source side
 - 2) Water flow source side - (Low)
 - 3) Water too cold source side
 - 4) Low refrigerant
 - b) Cooling
 - 1) Plugged heat exchanger on load side
 - 2) Water flow load side - (Low)
 - 3) Water too cold load side
 - 4) Low refrigerant
6. The high pressure switch may have tripped due to one or more of the following:
 - a) Heating
 - 1) Plugged heat exchanger on load side
 - 2) Low water flow load side
 - 3) Water too warm load side
 - b) Cooling
 - 1) Plugged heat exchanger on source side
 - 2) Low water flow on source side
 - 3) Water too warm source side
7. The compressor overload protection may be open.

8. The internal winding of the compressor motor may be grounded to the compressor shell. If so, replace the compressor.
9. The compressor winding may be open or shorted. Disconnect power. Check continuity with ohm meter. If the winding is open, replace the compressor.

If sufficient cooling or heating is not obtained:

1. Check control for improper location or setting.
2. Check for restriction in water flow.
3. Check refrigerant subcooling and superheat for proper refrigerant charge and expansion valve operation.
4. The reversing valve may be defective and creating a bypass of refrigerant. If the unit will not heat, check the reversing valve coil.

If the unit operation is noisy:

1. Check compressor for loosened mounting bolts. Make sure compressor is floating free on its isolator mounts. Check for tubing contact with the compressor or other surfaces. Readjust it by bending slightly.
2. Check screws on all panels.
3. Check for chattering or humming in the contactor or relays due to low voltage or a defective holding coil. Replace the component.
4. Check for proper installation of vibration absorbing material under the unit.
5. Check for abnormally high discharge pressures.
6. Compressor rotation incorrect

Preventive Maintenance

Unit Heat Exchanger Maintenance

1. Keep all air out of the water or antifreeze solution.
2. Keep the system under pressure at all times. Closed loop systems must have positive static pressure or air vents may draw air into the system.

NOTES: If the installation is in an area with a known high mineral content in the water, it is best to establish with the owner a periodic maintenance schedule for checking the water-to-refrigerant heat exchanger on a regular basis. Should periodic cleaning be necessary, use standard cleaning procedures. Generally, the more water flowing through the unit, the less chance there is for scaling. Low gpm flow rates produce higher temperatures through the heat exchanger. To avoid excessive pressure drop and the possibility of metal erosion, do not exceed gpm flow rate as shown on the specification sheets for each unit.

Replacement Procedures

When contacting the company for service or replacement parts, refer to the model number and serial number of the unit as stamped on the serial plate attached to the unit. If replacement parts are required, mention the date of installation of the unit and the date of failure, along with an explanation of the malfunctions and a description of the replacement parts required.

In-Warranty Material Return

Material may not be returned except by permission of authorized warranty personnel. Contact your local distributor for warranty return authorization and assistance.

Service Parts List

	Part Description	NHW084
Refrigeration Components	Compressor	34P632-01
	Compressor Sound Jacket	92P504A05
	Thermal Expansion Valve	33P618-01
	TXVs per circuit	1
	Filter Drier	36P500B02
	Reversing Valve with Coil	33P526-05
	Brazed Plate Heat Exchanger	62P581-01
	Heat Exchanger Support Bracket	47P589-01U
Safeties/ Sensors	High Pressure Switch	35P512-02
	Low Pressure Switch	35P512-01
	Water Temperature Sensor	12P529-04
	Freeze Detection Sensor	12S529-01
Electrical	Compressor Contactor	13P004A03
	Transformer	15P501B01
	Connection Block - Small	12P503-06
	Connection Block - Low Voltage	12S503-01
	Grounding Lug	12P004A
Control	FX10 Main Board - no communications	17X51606NDW-01
	FX10 Expansion Board	17P516-07
	FX10 Display Interface Board	19P580-02
Enclosure	Side Access Panel	40C661-01
	Front Panel	40P662-01P
	Top Panel (top water connections only)	42P565-01P and 42C547-03P
	Top Panel (rear water connections only)	42C547-01
	Rear Panel	40P662-01P
	Bottom Panel	41C543-01

2/14/12

Revision Guide

Pages:	Description:	Date:	By:
18	Updated Field Wiring and Control Setup	25 Feb 2013	DS
20	Updated Sequence of Operation	25 Feb 2013	DS
31	Added Revision Guide	25 Feb 2013	DS



Manufactured by
WaterFurnace International, Inc.
9000 Conservation Way
Fort Wayne, IN 46809
www.waterfurnace.com

Product: **5 Series 502W12**
Type: High Temp Hydronic Geothermal Heat Pump
Size: 7 Ton
Document: Installation Manual

